

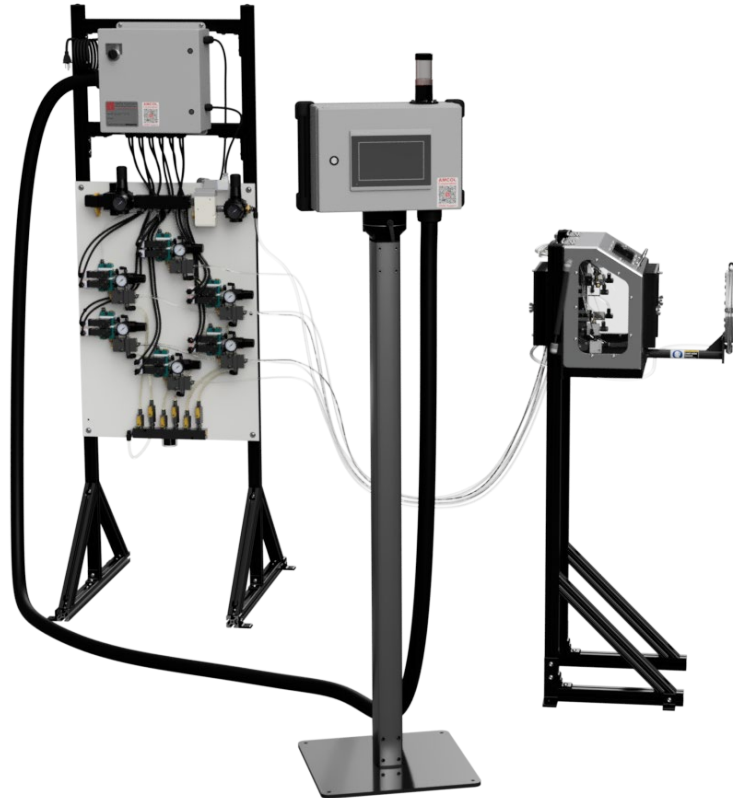

AMCOL CORPORATION

3200S ELECTRONICALLY CONTROLLED TUBE COATING SYSTEM Operator's Manual

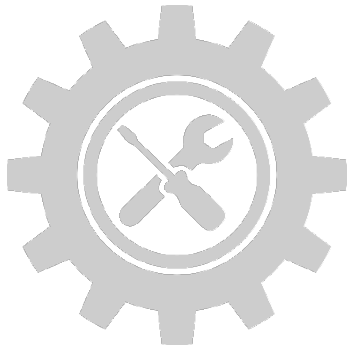

Contents

Introduction.....	3
Included Components	4
Installation	5
Operation.....	7
Before Starting the 3200S.....	7
Operating the 3200S	7
Stopping Operation	10
Using Preset Profiles	11
Saving Profiles	11
Loading Profiles.....	12
Using the Integrated Air Wipe.....	14
Recommended Settings	15
Maintenance	16
Recommended Spares	16
Preventative and Predictive Maintenance	17
Troubleshooting	18
Problems with Spray/Coating	18
Problems with Electrical Controls.....	19
Wiring Schematics.....	20
3200S - 4 Injector.....	20
3200S - 6 Injector.....	22
3200S - 8 Injector.....	24
3200S - 10 Injector.....	26



AMCOL Corporation

21435 Dequindre, Hazel Park, MI 48030	248-414-5700	fax: 248-414-7489	www.amcolcorp.com
---------------------------------------	--------------	-------------------	----------------------------------------------------------

Introduction

This manual features instructions regarding the installation, operation, and maintenance of the AMCOL 3200S Electronically Controlled Tube Coating System. For more information on the system and its components, please refer to the AMCOL 3200S Electronically Controlled Tube Coating System Technical Description.

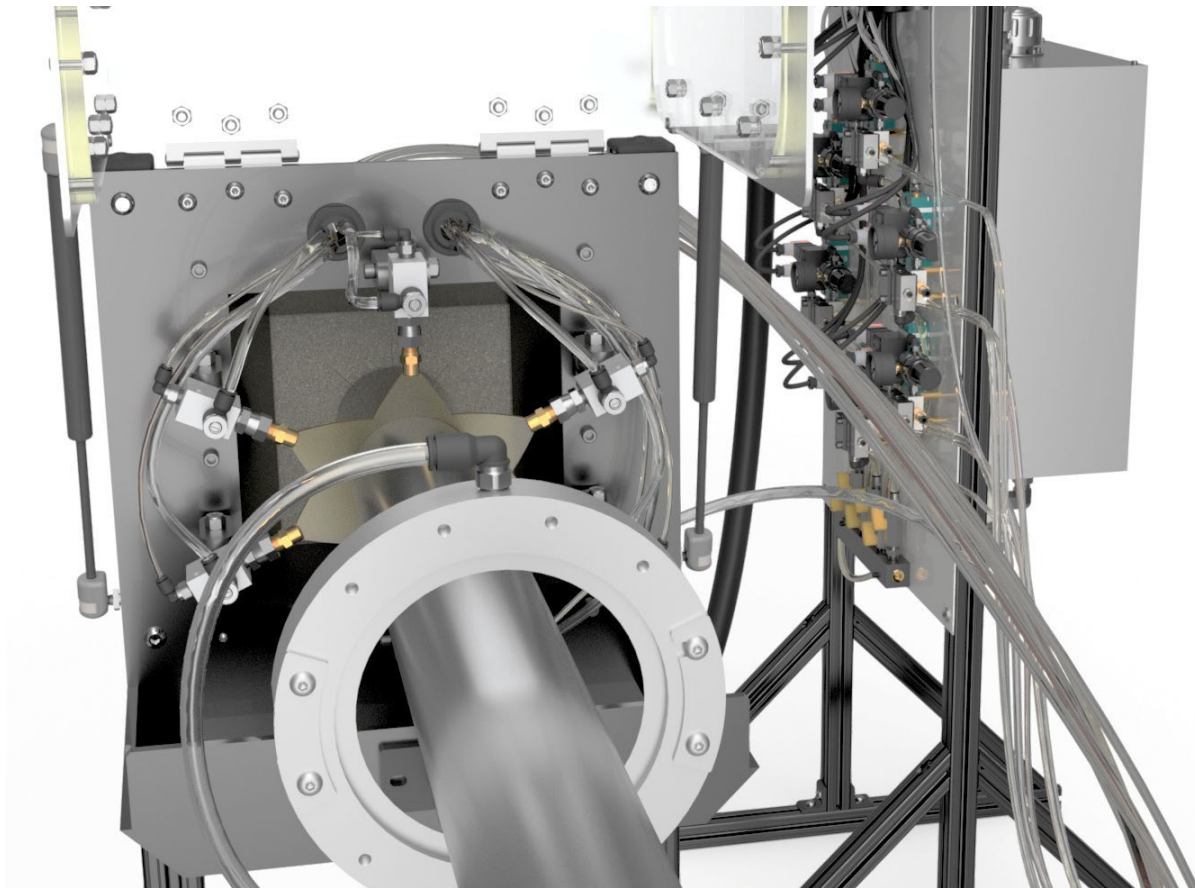

Included Components

Standard components included with every standard 3200S System:

1. Allen Bradley PLC** located inside a sealed enclosure
2. Allen Bradley HMI located on pedestal mount
3. Valve Pack including plate mounted T60A, dual solenoid, and manifold assemblies
 - 4, 6, 8, or 10 injectors
4. Spray assembly containing transition blocks and mounting assemblies
 - Spray box assembly or magnetic mount
5. 10 or 30-gallon reservoir with low level indicator tied to HMI enclosure
6. Mounting frame for valve pack, PLC enclosure, and reservoir
7. 10' of biaxial hose per injector

As an optional addition:

8. An EXAIR air-wipe blowoff and additional controls integrated with the system
9. A standalone, adjustable air wipe and additional controls

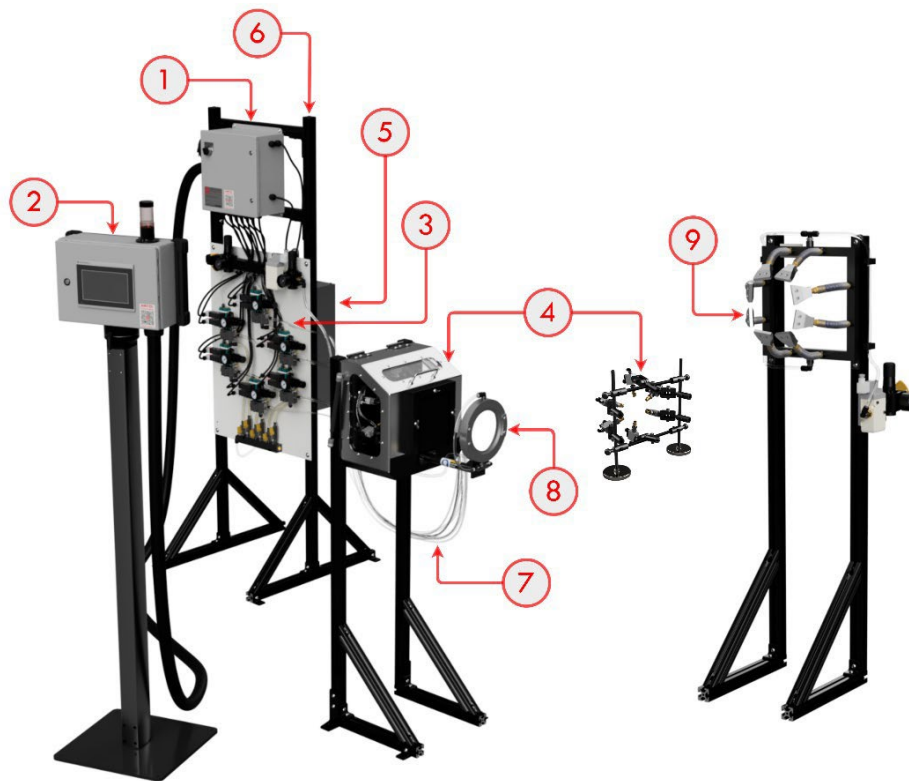

****NOTE:** Due to supply and part availability issues, PLC controls with sinking and sourcing outputs will be used interchangeably. This does not impact functionality.

Installation

PRIOR TO GETTING STARTED

• **WARNING!** Never adjust this system while mill is in operation. Mill must be properly turned off, locked, and tagged during any system adjustment!

• **WARNING!** ENSURE ALL SYSTEM COMPONENTS THAT DO NOT NEED TO BE ACCESSED REGULARLY ARE INSTALLED BEHIND GUARDING!

• **WARNING!** Never use this system to dispense flammable or combustible liquids!

• **WARNING!** Use only chemicals that are compatible with steel, aluminum, and brass!

• **WARNING!** Be sure to properly shut-off system air/power and lock/tag before any repairs are started on this system!

• **WARNING!** THIS SYSTEM OPERATES USING 110VAC AND 24VDC. DO NOT TOUCH ANY BARE OR EXPOSED WIRES OR TERMINALS WITHOUT CONFIRMING THE SYSTEM IS POWERED DOWN!

1. Review the complete system to ensure that damage has not occurred in shipment.
2. Place the complete pallet as close as possible to installation point. It is recommended that the system be operated off line before installation in order to allow for a more thorough understanding of system controls prior to active use.
3. Mount the spray containment box or spray assembly in position and attach it to the mounting location so that the spray assembly is centered with the tube.
4. Mount the controls so that the operator can easily see the solenoids and injectors to ensure they are working correctly.
5. Mount the HMI stand so the operator has access to change active operation settings.
6. Connect a ½" NPT plant air source and adjust the ½" regulator to 60 psi.
7. Connect the encoder to the inputs of the PLC. If using a single output encoder, connect output A to input 0 (I-00) on the PLC. If using a quadrature output encoder, connect output A to input 0 (I-00) and output B to input 1 (I-01).



8a. *If using the provided power cable, plug the cord into a 110V AC outlet.*

8b. *If using a plant power source, insert a 110V AC cable into the cord grip on the top left of the PLC enclosure. Attach the live/hot wire to terminal 4 on the toggle switch. Attach the neutral wire to terminal 2 on the terminal block. Attach the ground wire to terminal 3 on the terminal block.*

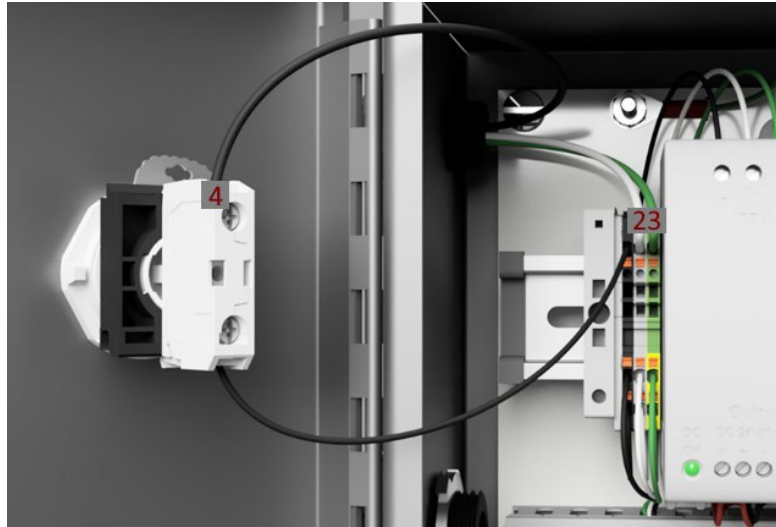

9. Fill reservoir with the appropriate coating oil.

10. Open the ball valve to the strainer on the bottom of the reservoir, and open the ball valve to each pump on the liquid supply manifold.

11. Operate injectors individually until fluid has reached all spray points.

12. The system is now ready to operate.

Operation

Before Starting the 3200S

1. Properly set-up and adjust tube profile according to production requirements.
2. Cut off tube prior to spray box position.
3. Place spray box in position so that profile is centered in spray assembly.
4. Using the multifunctional mounts, adjust each Transition Block to evenly coat the profile. Flat Spray Nozzles provide a 2" spray width at 2" from the profile. The nozzles can be rotated if necessary.
5. Ensure the ball valve to the strainer on the bottom of the reservoir is open, and ensure the ball valve to each pump on the liquid supply manifold is open.
6. Top off the reservoir as necessary. The light on top of the HMI enclosure will flash if the reservoir is low.

Operating the 3200S

1. Turn on the toggle switch to power the PLC and HMI on. *

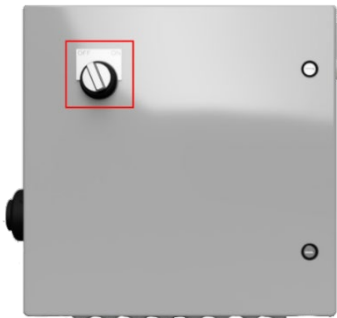

*** On initial startup, the HMI will take a few seconds to register touching the screen**

2. Once the screen turns on, check that the System Status is “Off.” If it is not, touch the System Off button.

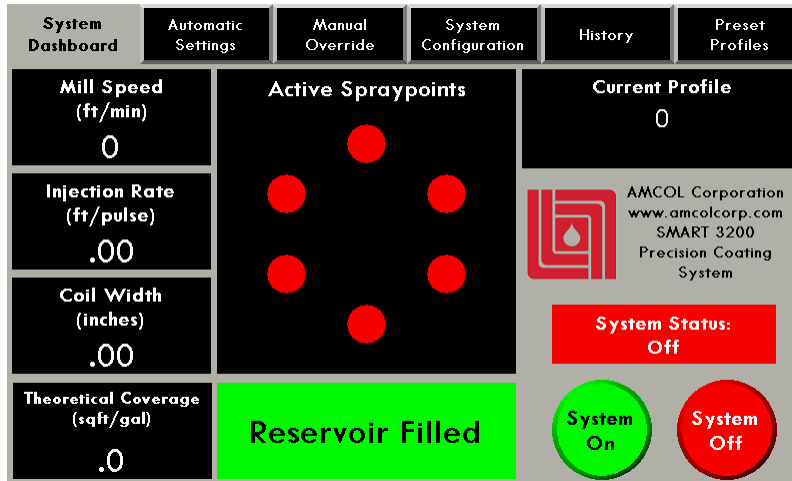

3. Touch the Automatic Settings selection button and select which pumps should be active to best coat the profile. If a pump is red, it is off. If a pump is green, it is on. Next, input the Coil Width in inches and select the Injection Rate.

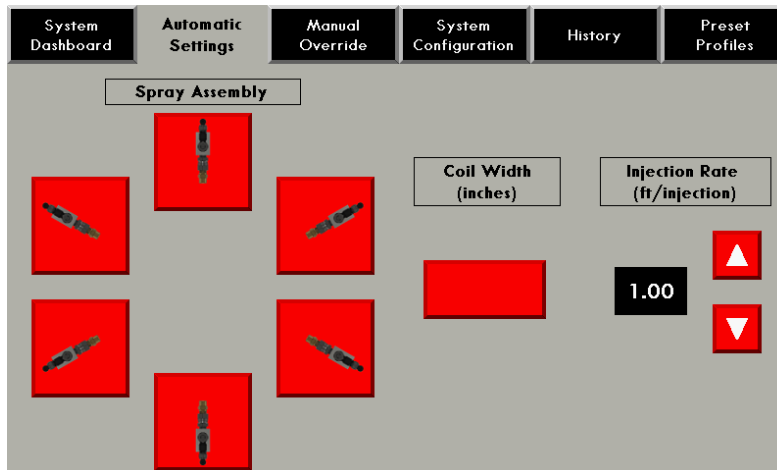

4a. **If using Encoder Input**, touch the System Configuration button. The screen should appear as it does below. Touch login and type in the case-sensitive information below.

Username: admin

Password: 3200S

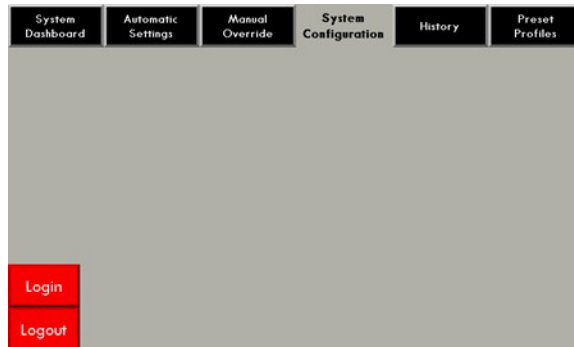

The buttons to input the encoder settings should now appear. These buttons will only remain visible as long as the admin user is logged in. Enter in the settings for your encoder. After modifying any settings, make sure to log out so other operators cannot modify the values. The encoder settings and the ability to save and delete profiles are the only settings not visible to anyone not logged in—no other functionality is lost by not being logged in.

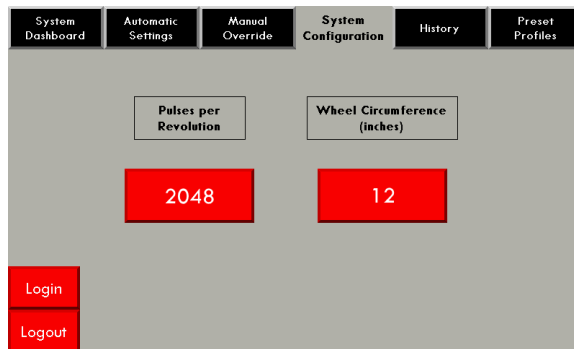

4b. **If using the encoder input, move to step 5.** To use manual input, touch the Manual Override button. Select the Mill Speed and Injection Rate and touch Activate Manual Input. Select which pumps should be active (if a pump is on the button will be green). Touch System Dashboard to return to the main screen. When using Manual Override, the System Status box will display “Manual Override” while the System is On.

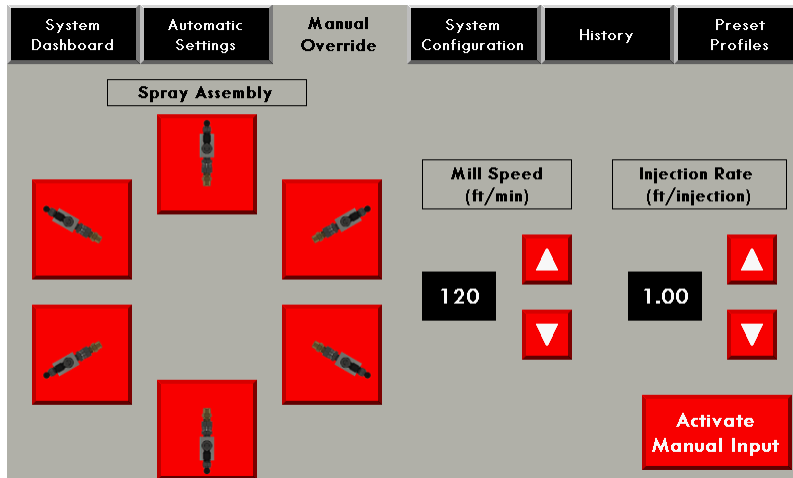

5. Return to the System Dashboard and touch System On. The machine should begin running. The user should be able to observe the output lights on the PLC, the lights on the solenoids, and the pumps all activating in unison.

Stopping Operation

1. Touch the STOP button so that the System Status displays "Off".

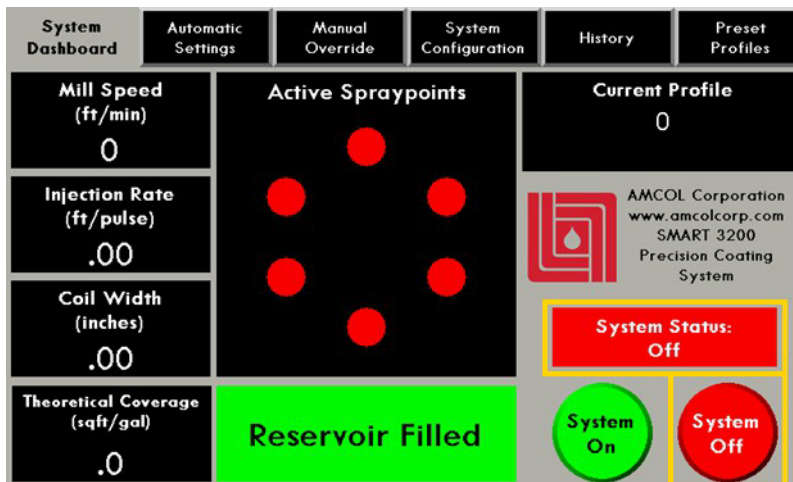

2. Go to either the Automatic Settings or Manual Override screens and deactivate any active pumps. Pumps are deactivated if they are red.

3. Before toggling the power switch, ensure the System Status reads "OFF" and that all pumps are disabled. When the PLC turns off and on, it operates based on the set parameters before it was powered off. ***If the machine is running when it loses power, it will continue running with the same settings when power is restored.***

Using Preset Profiles

Preset Profiles allow you to save up to 100 commonly used profiles. After setting which nozzles are active, the injection rate for proper coating volume per foot, and the width of the strip, you can save the settings for quick one-button set up.

Saving Profiles

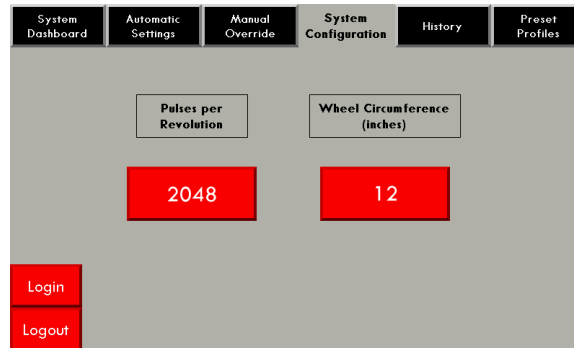

1. The user must be logged in to save profiles. See step 4a of "Beginning Operation" for login instructions and information.

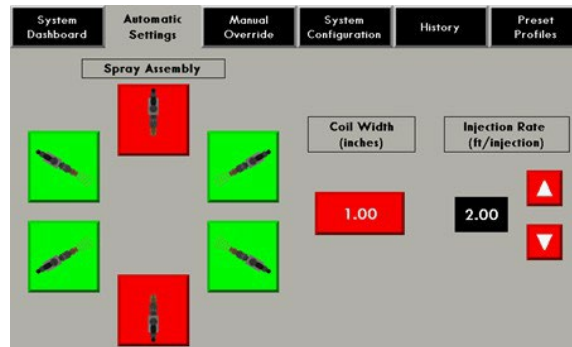

2. In the "Automatic Settings" tab, select the desired nozzle configuration, injection rate, and coil width for the profile.

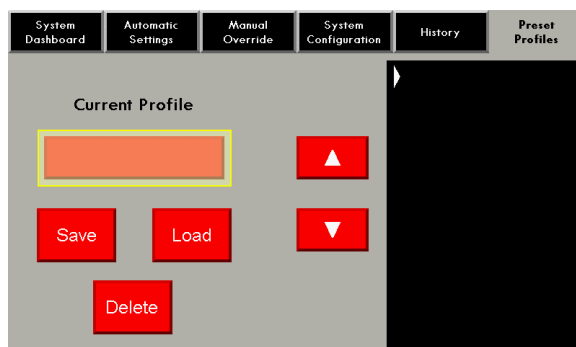

3. Select the "Preset Profiles" tab. Touch the "Current Profile" box. A dialog window will appear. Type in the name for the profile and press Enter. Profile names can be up to 14 alpha-numeric characters.

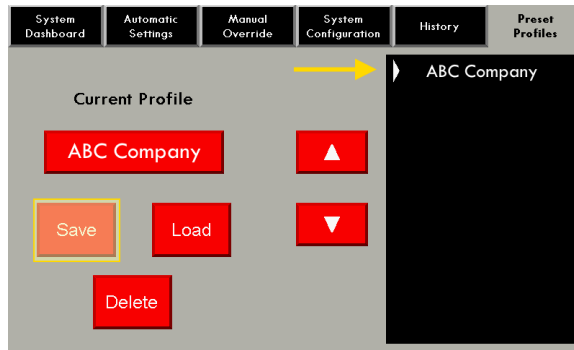

4. Touch the Save button to save the profile. Saved profiles will automatically sort from 0-9, then A-Z. Up to 100 profiles appear in a list on the right of the screen, so it is important that you determine a method for naming profiles that allows them to be easily found. Profiles must be named prior to being saved. Attempting to save a profile without a name will display an error.

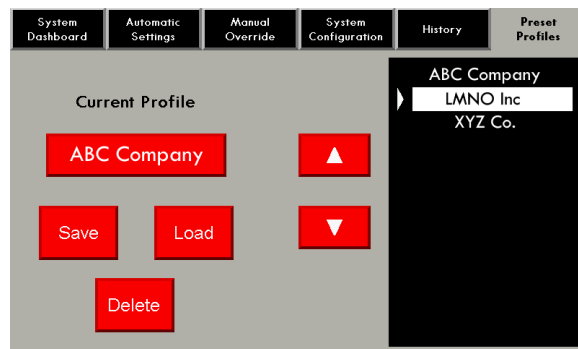
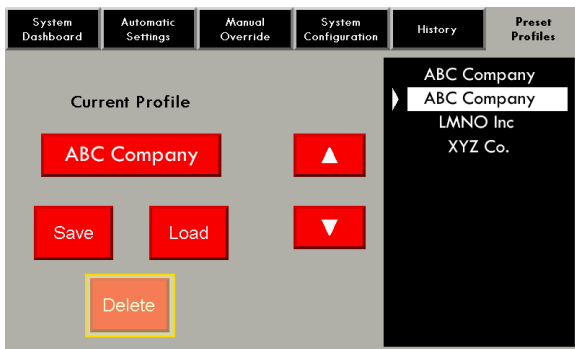

5. If a profile is no longer needed, use the up and down arrows to scroll to the profile and touch the delete button. This will remove the profile and any associated settings.

Loading Profiles

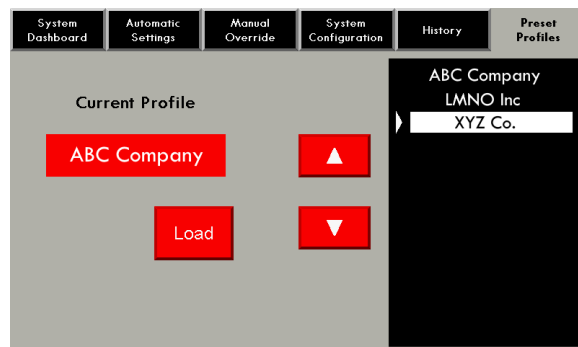
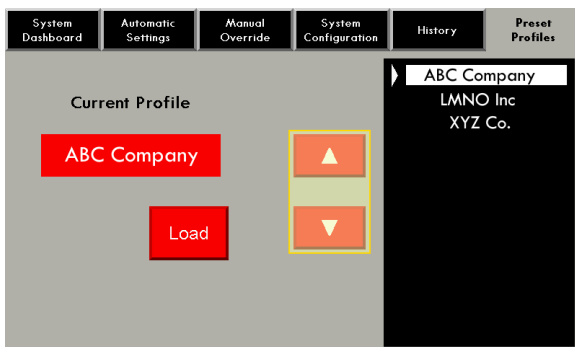

1. In the Preset Profiles tab, use the up and down arrows to highlight the profile you would like to activate. The user does not need to be logged in to activate a profile. 10 profiles appear in the window at a time. Scrolling up or down at the top or bottom allows you to scroll to the rest of the list.

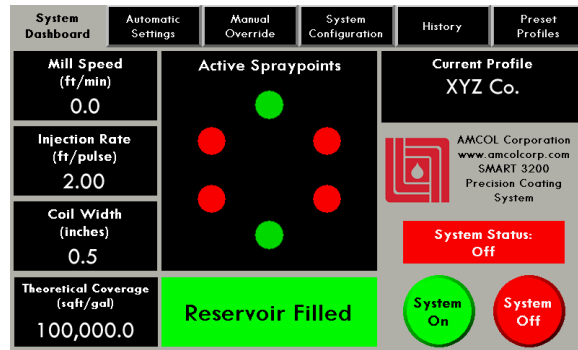
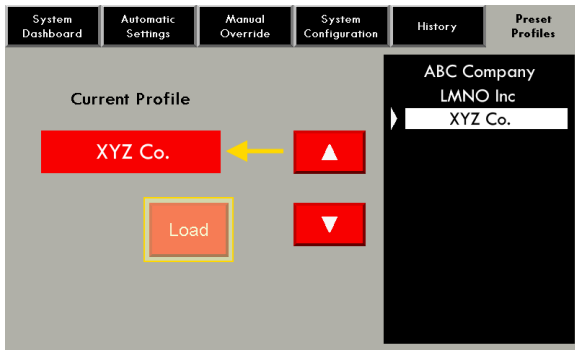

System Dashboard	Automatic Settings	Manual Override	System Configuration	History	Preset Profiles
Alarm Message		Time	Date	Ack All	
Profile Loaded: XYZ Co.		10:16 AM	11/11/2022	Clear All Alarms	
				Clear All Alerts	

2. Touch the load button. The active settings will automatically change. On the system Dashboard screen, “Current Profile” will display the loaded profile in the top right. When a profile is loaded, it will be displayed in the history tab. The history tab contains the last 10 events and alarms only.

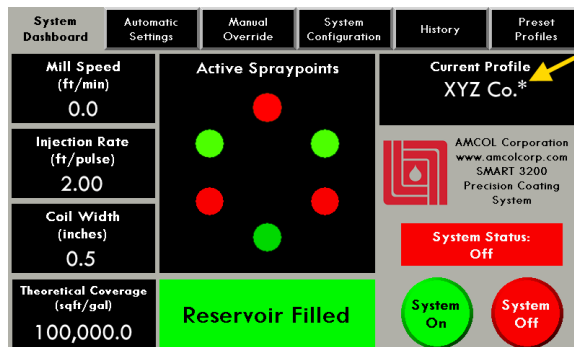

3. The user can manually change the injector configuration, coil width, and injection rate after a profile is loaded. An asterisk will display to the right of the profile name. Reloading the profile will restore the original settings and the asterisk will no longer appear.

Using the Integrated Air Wipe

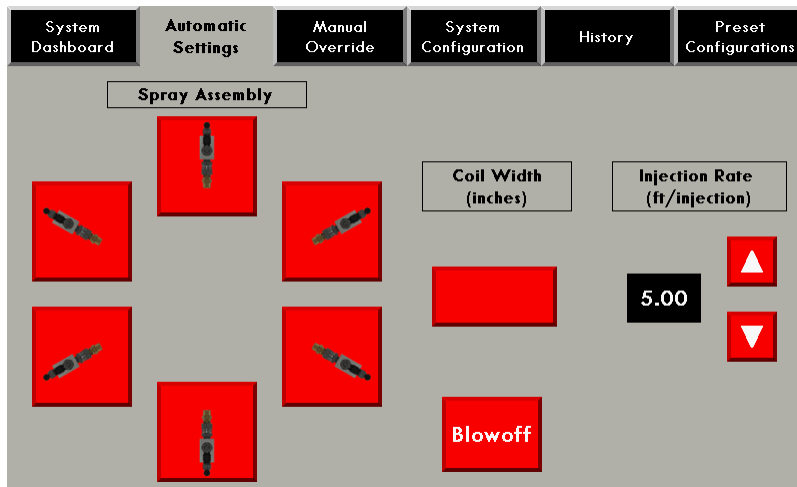

1. Go to either the "Automatic Settings" screen or the "Manual Override" screen.

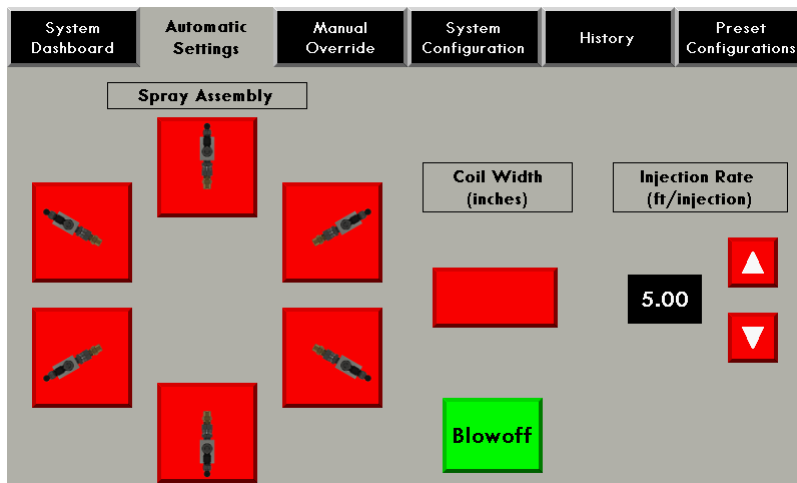

2. Press the button that says "Blowoff." When the button is green, the air wipe is on. When the button is red, the air wipe is off.

Recommended Settings

1. System Pressure – 60 psi while system is operating.
2. Air Pressure to Spray – 20 psi.
3. Flow Control on Transition Block – Approximately 2.0 Turns from closed. Set so as not to atomize or fog liquid.
4. Air Pressure to Air Wipe (optional) – start at 20psi, increase as necessary.

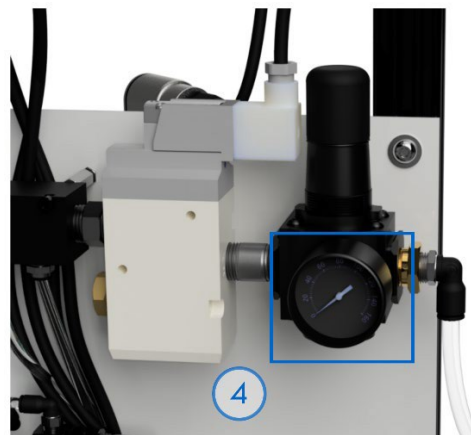
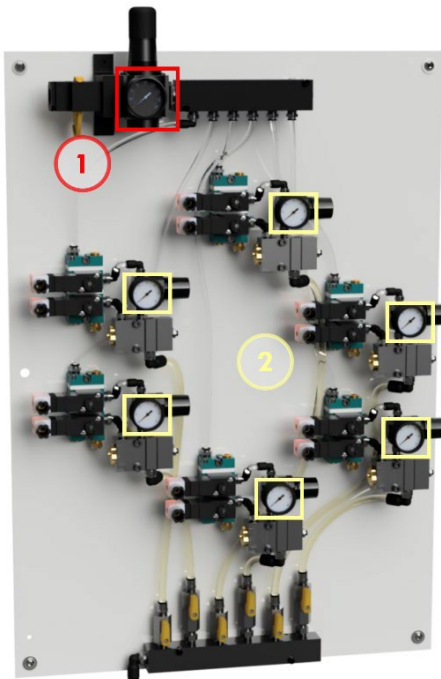

Maintenance

Recommended Spares

	Part Description	Part Number	Quantity
	T60A Posi-pump, 1 Injector, No PFG, Fixed Volume 1.5T	T60A-1-X-1.5T	1
	T60 Repair Tool	RT-T60	1
	T60A Repair Kit	T60A-RK	1 per injector
	24V DC Solenoid w/ Lighted Cap	183B-502JD	2
	3200S Spray Nozzle Assembly	3200S-NF30120	1 per injector
	Biaxial Hose	6000-B-BH1	10' per injector
	1/8" Capillary Hose for Liquid Line	6000-70-30NOZ	1' per injector
	P/H Urethane Tubing (3/8" OD)	U-64	5'
	80 Mesh Replacement Screen for T-Strainer	9875K82	1
	Clear Bowl for 1/2 In-Line Strainer	9875K11-AC	1
	0-30 psi Pressure Gauge	3847K72	1



Preventative and Predictive Maintenance

Daily

- Observe fluid level and fill as necessary.
- Observe all pressure settings and gauges to be consistent with recommended settings.
- Check ½" inline strainer for sediment and solids. Clean or replace if required. Identify root cause.
- Observe spray coating, quality, and pattern. Make adjustments or repairs as necessary.

Quarterly

- Completely empty reservoir. Wash with water. Refill.
- Change clear bowl and gasket for ½" inline strainer.

Yearly

- Rebuild all T60A injectors.
- Replace all air regulator pressure gauges.
- Replace all air and liquid hose.

Troubleshooting

Problems with Spray/Coating

1. No Fluid at Tip or Tips
 - a. Reservoir is empty. Fill.
 - b. Mesh Filter is clogged. Clean or replace.
 - c. Solenoid not opening. Replace.
 - d. Injector inoperable. May be dirty or eroded.
2. Fluid Volume Inappropriate
 - a. Adjust injections per foot setting.
 - b. Adjust number of active injectors.
3. Inconsistent Spray Volume to One Spray Point
 - a. Capillary hose inside spray tip is clogged. Clean or replace.
 - b. Spray tip not properly attached. Reconnect or replace.
 - c. Liquid or air hose is severed or incorrectly attached. Reconnect or replace.
4. Inconsistent Spray Volume to All Spray Points
 - a. Fluid Level is low. Refill reservoir.
 - b. Strainer is clogged. Clean or replace.
5. Mist or Fog
 - a. Atomizing air pressure set too high: adjust regulator to 20 psi or below.
 - b. Atomizing airflow set too high: adjust flow controls on transition block.
6. Liquid from Back of Injector
 - a. Injector contact seals leaking: clean injector and replace o-ring.
7. Profile not Completely Coated
 - a. Rotate Flat Spray Nozzle for more complete coverage.
 - b. Increase number of injectors in use.
 - c. Increase injections per foot.
 - d. Review coolant removal.



Problems with Electrical Controls

1. Mill speed display on HMI incorrect
 - a. Confirm correct encoder configuration settings. Change if incorrect.
 - b. Check encoder connections on PLC. Fix if loose/not connected.
 - c. Confirm encoder signal is 24V DC.
 - d. Check encoder signal with oscilloscope.
2. HMI showing errors / buttons do not work when pressed
 - a. Confirm system status is ON.
 - b. Check output lights on PLC/solenoids.
 - c. Check serial cable connections. Connect if loose.
3. Low level indicator light not operating
 - a. Check wiring. LLI should be connected to input 4 and a +24V DC connection.
 - b. Check operation of float switch. It should easily move.
 - c. Check continuity of float switch. Replace if broken.

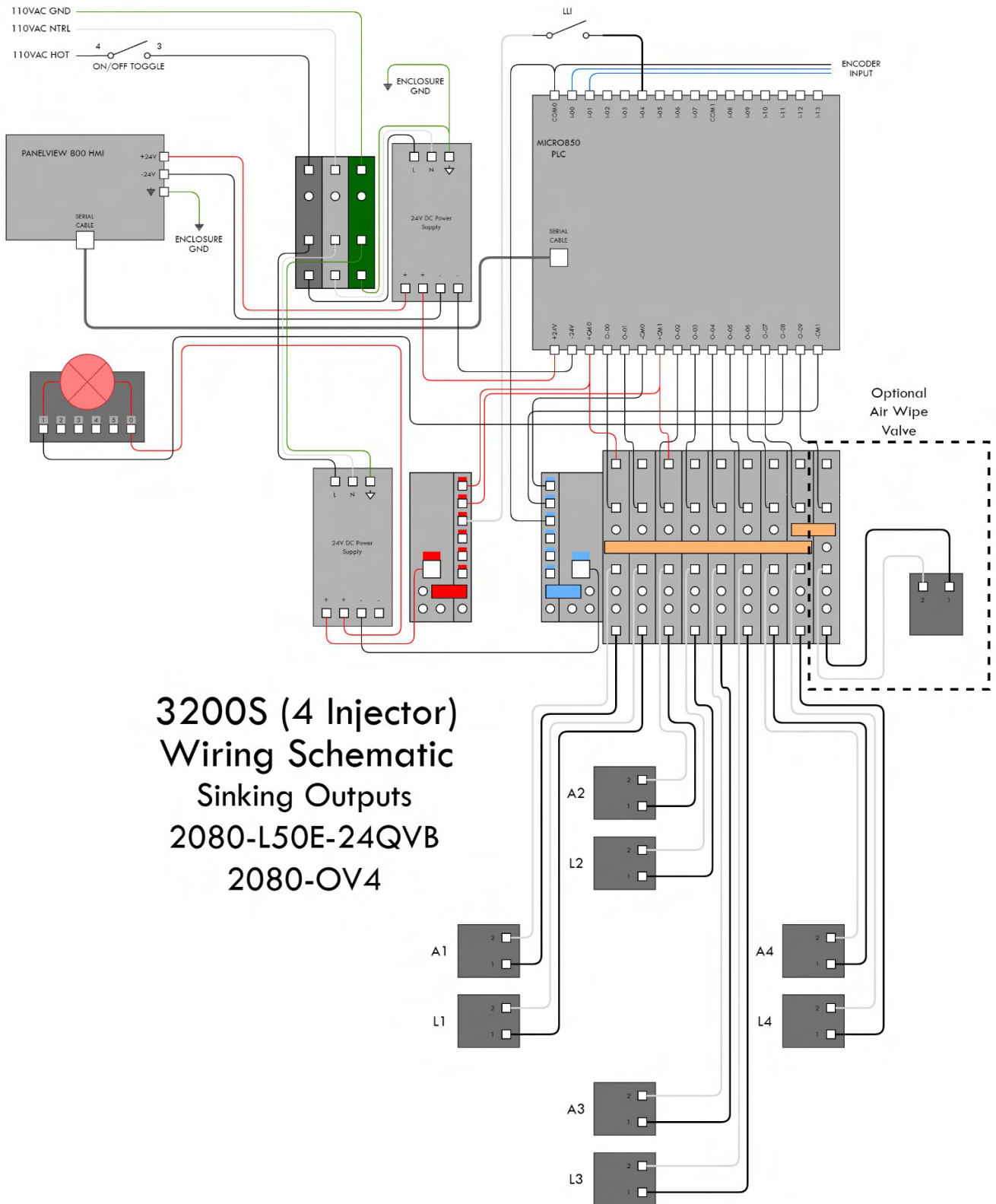

**3200S (4 Injector)
Wiring Schematic
Sinking Outputs
2080-L50E-24QVB
2080-OV4**

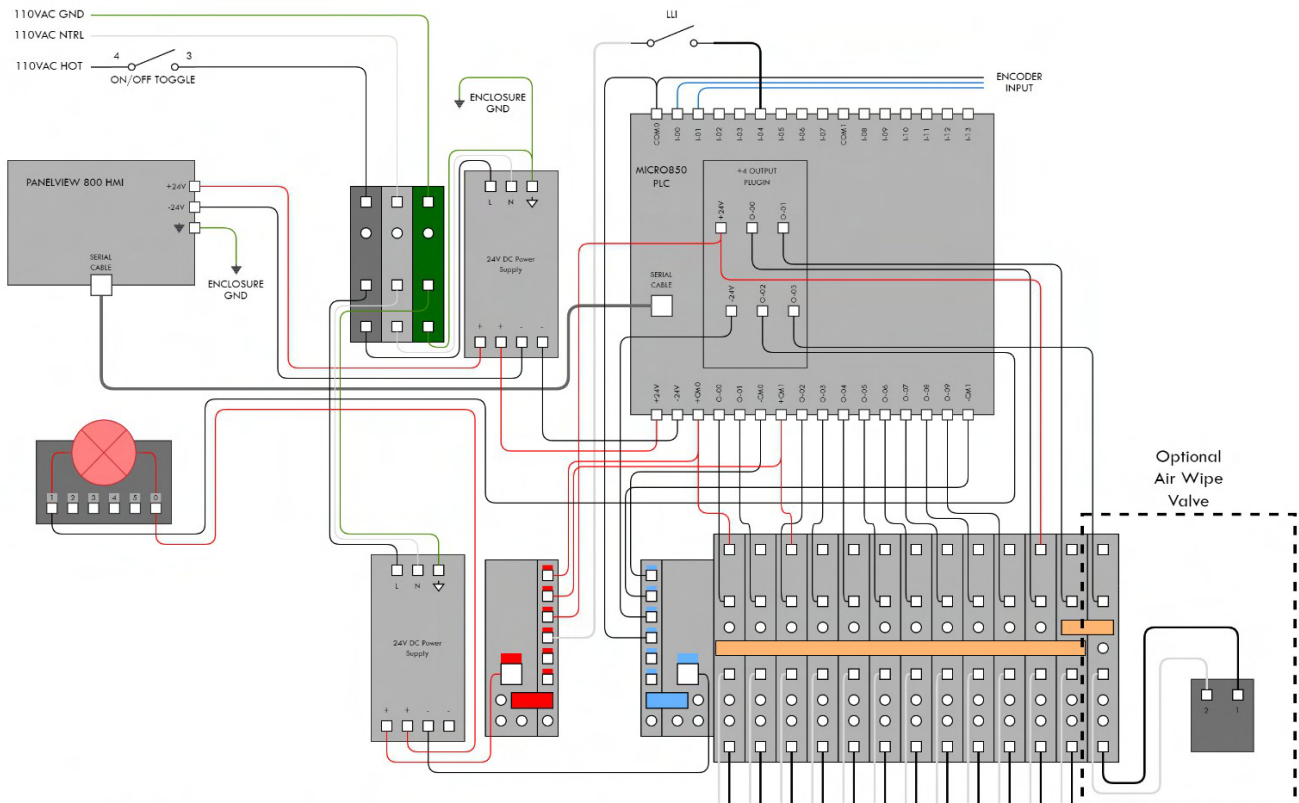

**3200S (6 Injector)
Wiring Schematic
Sinking Outputs
2080-L50E-24QVB
2080-OV4**

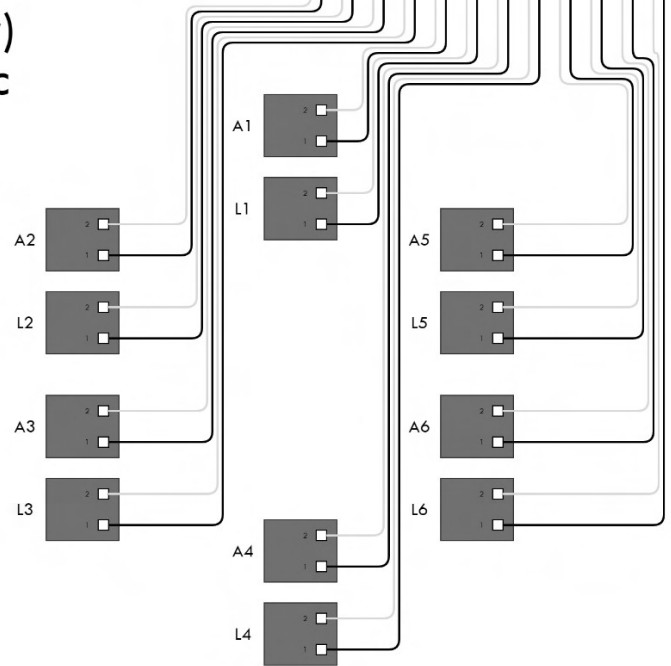

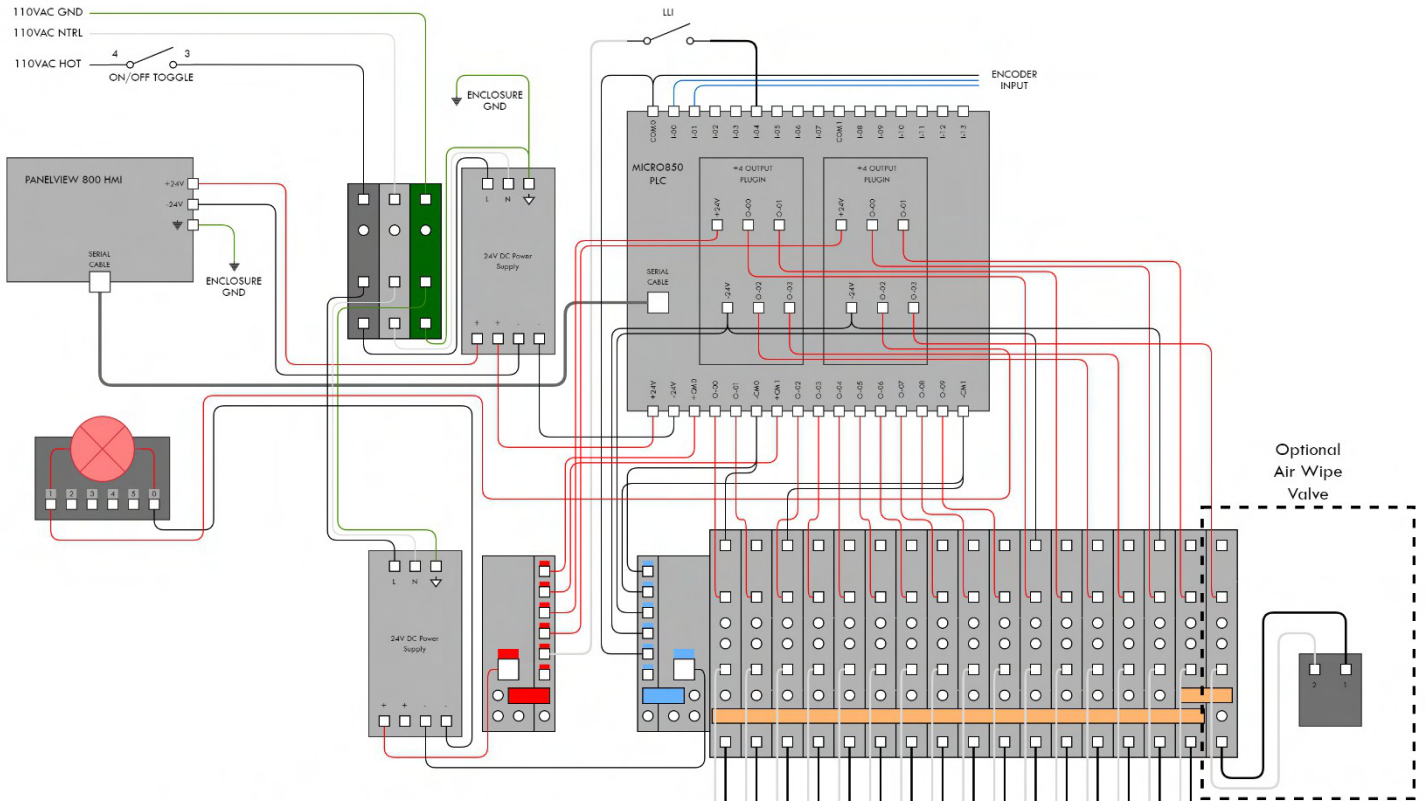

**3200S (8 Injector)
Wiring Schematic
Sourcing Outputs
2080-LC50-24QBB
2080-OB4**

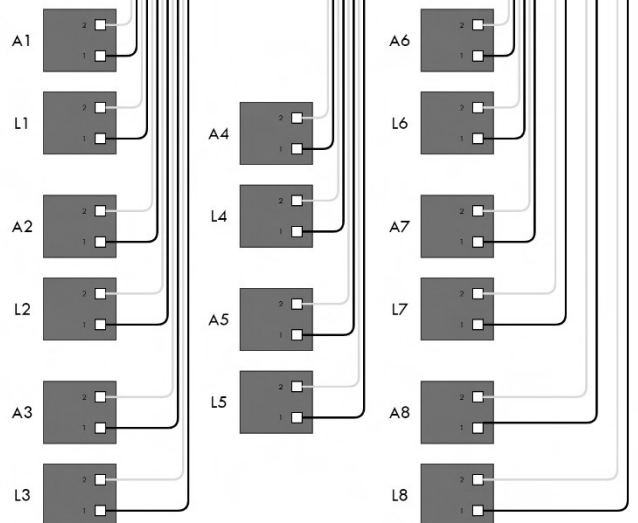

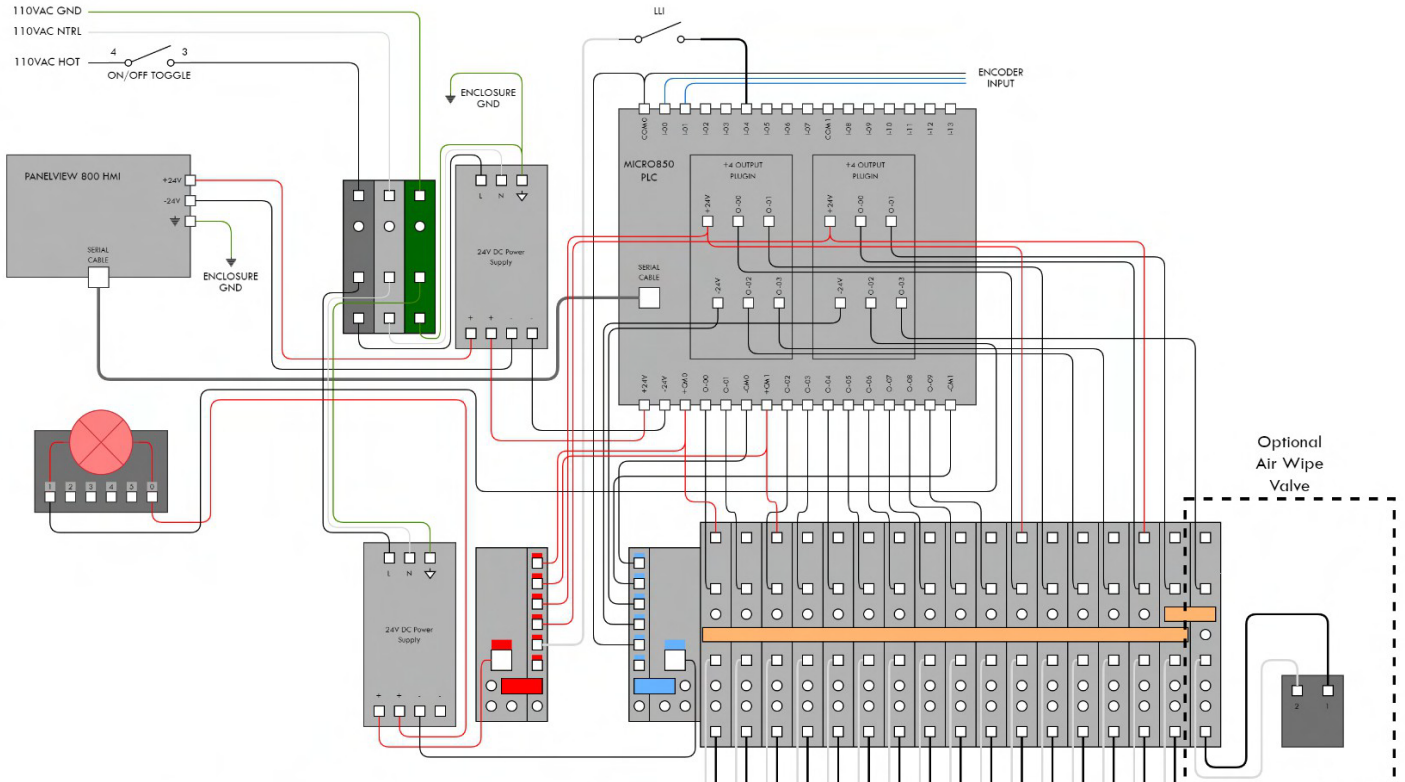

**3200S (8 Injector)
Wiring Schematic
Sinking Outputs
2080-L50E-24QVB
2080-OV4**

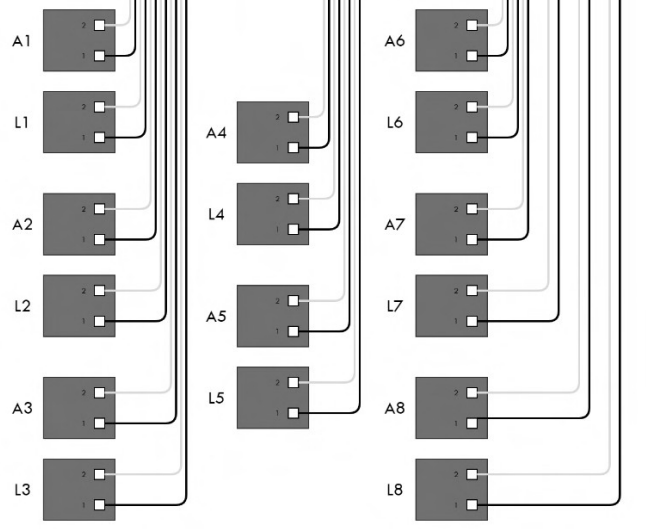

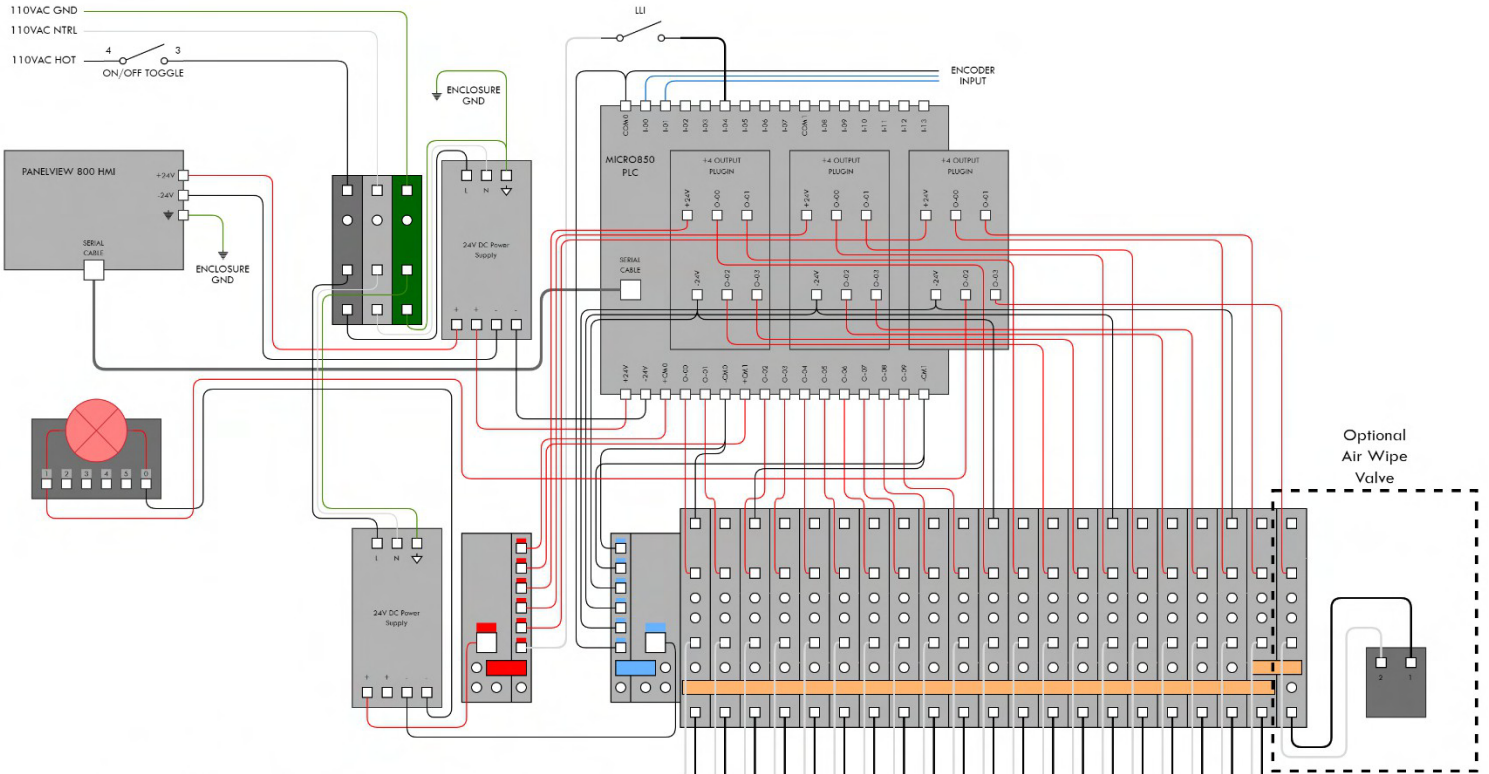

**3200S (10 Injector)
Wiring Schematic**
Sourcing Outputs
2080-LC50-24QBB
2080-OB4

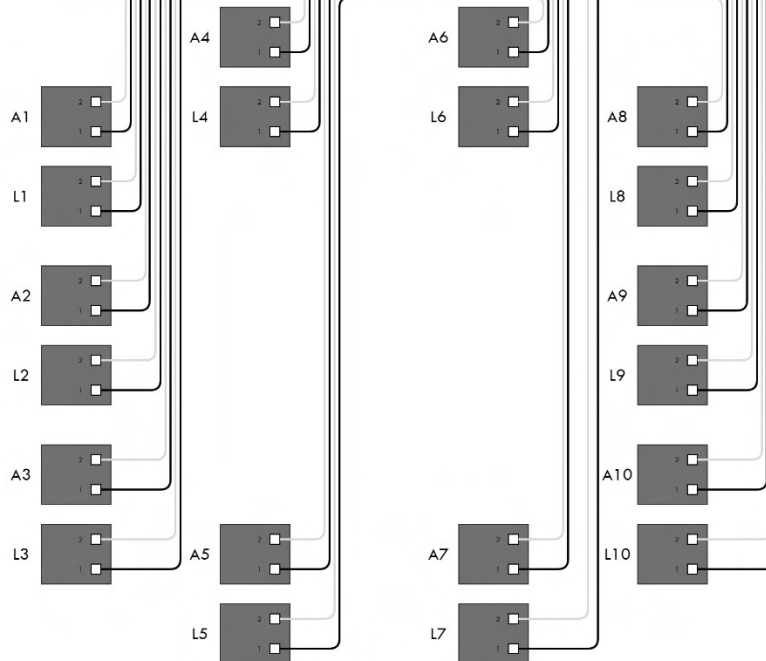

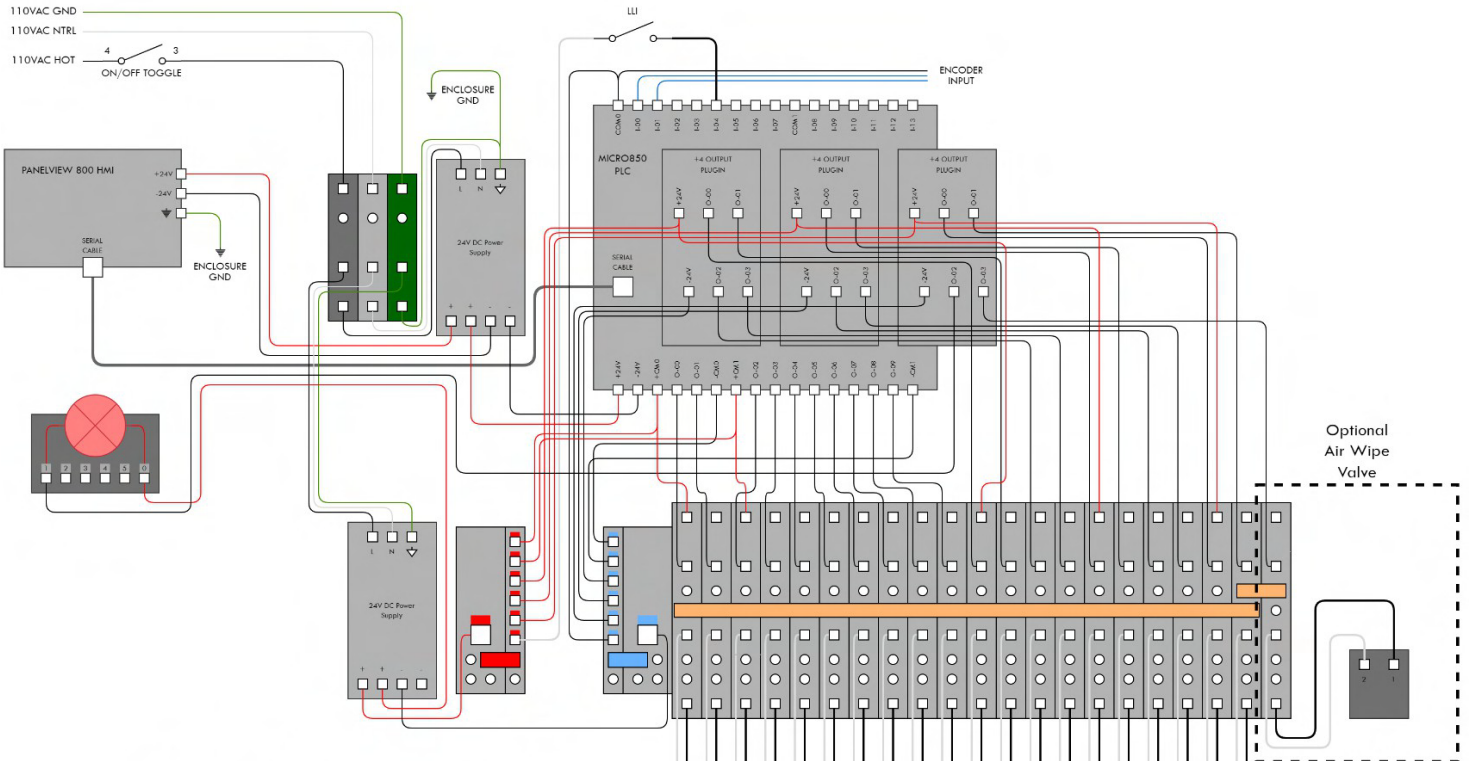

**3200S (10 Injector)
Wiring Schematic
Sinking Outputs
2080-L50E-24QVB
2080-OV4**

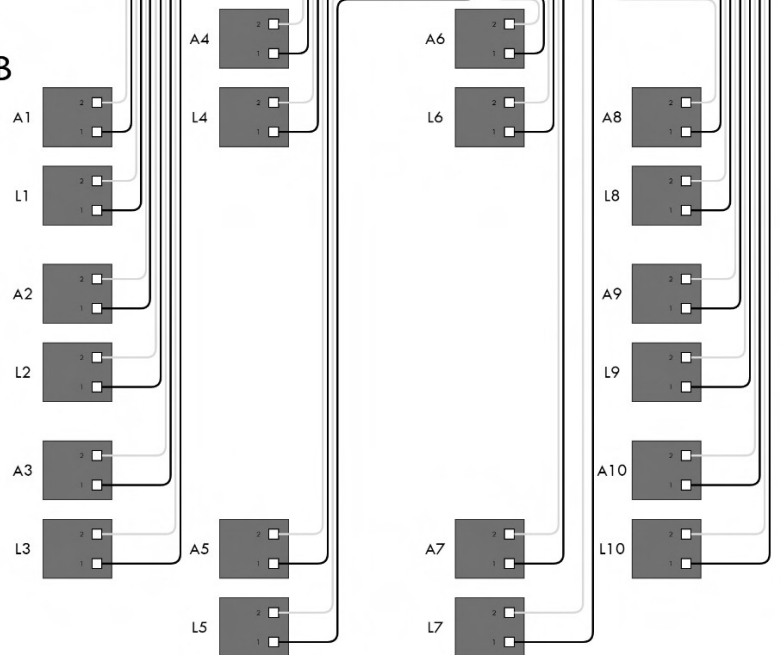



AMCOL Corporation

21435 Dequindre, Hazel Park, MI 48030	248-414-5700	fax: 248-414-7489	www.amcolcorp.com
---------------------------------------	--------------	-------------------	----------------------------------------------------------