

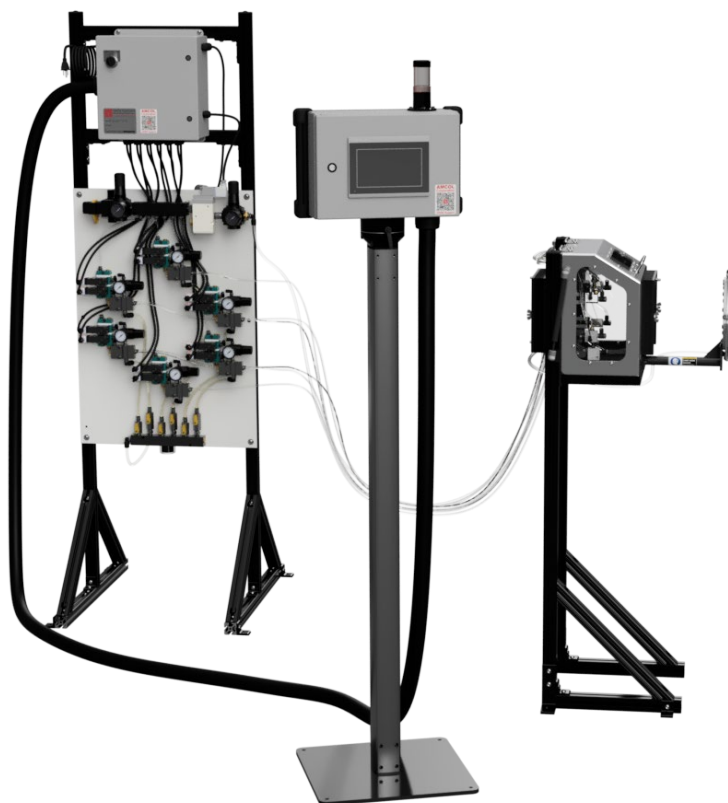

AMCOL CORPORATION

3200S ELECTRONICALLY CONTROLLED TUBE COATING SYSTEM Technical Description

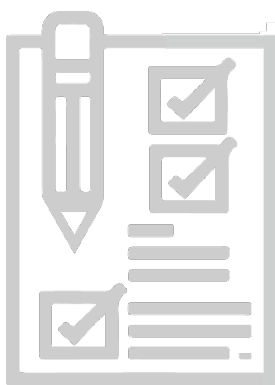

CONTENTS

1	Introduction to In-Line Tube Coating with AMCOL.....	2
2	System Overview	3
3	Description of Components.....	4
3.1	Controls	4
3.2	Valve Pack.....	4
3.3	Spray Box.....	5
3.4	Reservoir.....	5
3.5	Air Wipe (Optional)	5
4	System Features	6
5	Alternative Options & Accessories	8
5.1	Spray Mounting Options	8
5.2	30-Gallon Reservoir	8
5.3	Standalone Air Wipe – 3200S-AB-10	8
6	How To Order	9
7	Additional Information	10



AMCOL Corporation

21435 Dequindre, Hazel Park, MI 48030	248-414-5700	fax: 248-414-7489	www.amcolcorp.com
---------------------------------------	--------------	-------------------	--

1 INTRODUCTION TO IN-LINE TUBE COATING WITH AMCOL

In the early 90's, AMCOL identified the need to better control and contain the application of rust preventatives applied to welded tubes and cold roll formed profiles. In May of 1994, the "RP2000" corrosion preventative system was patented. This system was designed to spray the surface of the profile and collect excess overspray. Our mission was to apply an even and predictable rust preventative film.

The original design was soon updated to incorporate high-precision positive displacement injection metering using the AMCOL T60A Posi-pump. This allowed users to more accurately set and adjust the liquid output volume.

Design improvements continued over the years with enhanced spray box designs, improved air/liquid mixing techniques, and others, to aid in system installation, operation, and maintenance. After years of countless refinements, we are now introducing the greatest evolution yet—PLC control that is tied to your mill speed.

The AMCOL Model 3200S Electronically Controlled Tube Coating System incorporates a simple touchscreen interface that allows your operator to set up each job by choosing nozzle locations and coverage volume to accommodate different profile sizes and shapes. This system can monitor production line speed by interfacing with the mill encoder wheel. Once set, the volume output per spray point ramps up or down so coverage remains exactly as you set it.

The HMI screen verifies mill speed, coverage in square feet per gallon, which nozzles are active, reservoir fill status, and the system settings. The injectors on the control panel are configured the same as the touchscreen and light up when in use to allow visual confirmation the injectors are cycling.

The AMCOL Model 3200S Electronically Controlled Tube Coating System allows AMCOL customers to achieve the maximum benefit from our performance driven CANT RUST corrosion preventative coatings. Together, the 3200S and CANT RUST give you a level of quality, process control, predictability, reliability, and cost benefit that cannot be matched. CANT RUST is the barrier protecting your tubes, and the 3200S is your way of knowing it is being applied correctly.

Using the AMCOL Model 3200S Electronically Controlled Tube Coating System, your customers will know that you are using the best available technology to ensure their tubes are coated consistently and predictably.

2 SYSTEM OVERVIEW

The AMCOL Model 3200S In-Line Coating System is used to accurately apply CANT RUST oil and water-based rust preventatives onto continuous profiles such as tubes, pipes, and other roll formed shapes.

This system incorporates the accurate, repeatable, and reliable AMCOL T60A Posi-pump to injection meter liquids to individual spray points. An individual injector is assigned to each spray point. Injection rate per foot is tied to mill speed using a PLC-encoder interface. Because the output per injection cycle is fixed, output per linear foot is set and determined solely by changing the injection rate per foot.

Individual spray points can be rotated and moved around the profile to ensure complete coating of the profile. Spray points can be turned off and on using a touchscreen HMI.

By knowing the number of spray points, coil width, injection rate, and mill speed, a theoretical coating weight can be calculated and viewed on the HMI diagnostics screen.

Settings specific to one customer or tube profile can be determined and repeated with each production run. Recipe settings can be saved to simplify mill setup when switching batches.

The 3200S spray box collects any overspray that misses the profile in order to minimize the cross contamination of mill coolants and rust preventatives, while also offering protection for the spray points and reducing particulate in the plant.

Components of the system include:

- Allen Bradley PLC with a touch screen interface.
- Fluid/air control panel with up to eight AMCOL T60A Posi-Pumps.
- Spray box with individual air/liquid mixing blocks.
- 10-gallon reservoir with low level indicator.
- T-slot mounting to integrate components and ease installation.

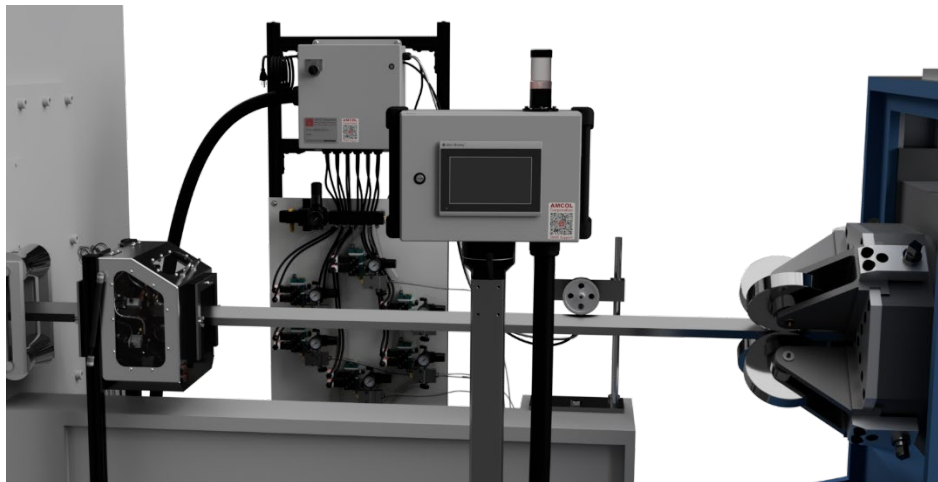

3 DESCRIPTION OF COMPONENTS

3.1 CONTROLS

The system is controlled by an Allen Bradley PLC interfacing with an Allen Bradley touch screen HMI. Through the HMI, the user can individually enable and disable T60A posi-pumps based on the object profile. When the system is connected to the mill encoder, the 3200S will dynamically adjust the cycle rate of the pumps based on the mill speed. Manually entering a mill speed is also possible. A signal is then sent to each solenoid to control injection rate to each spray point. Profiles can also be created to easily save and load settings for a specific customer or tube.

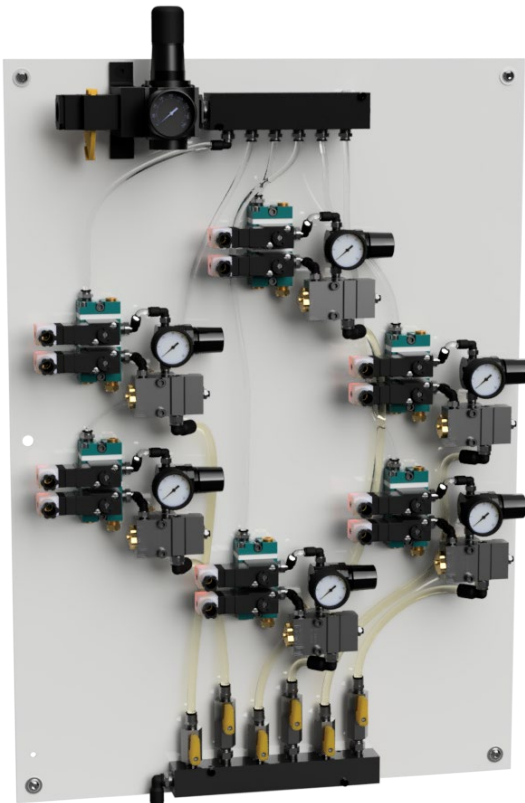
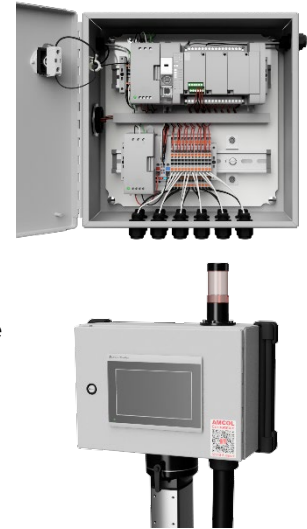

3.2 VALVE PACK

Fluid and air controls are plate mounted for ease of viewing and adjustment. PLC actuated 24V DC solenoids control airflow to injectors and manifolds. These solenoids also include LEDs that turn on when the valve is open to aid in viewing.

Fluid output is injection metered using the T60A Posi-pump positive displacement pump. One pump is connected to each spray point. Injection rate can be adjusted through the feet per injection option on the HMI. Each injector can be turned off and on to match the number of injectors required for the size of the profile.

An adjustable air regulator is used to meter air pressure to the spray tip.

Air and liquid travel side by side (biaxial) to the spray box at which point the liquid line is transitioned to be inside the air (coaxial). Air and liquid are finally mixed and propelled to the surface of the profile.

3.3 SPRAY BOX

The spray containment assembly aids in containing overspray and provides a mounting point and protection for the transition blocks. The spray containment box is mounted with adjustable T-Slot. Each spray point assembly utilizes multifunctional mounting brackets so the transition blocks can be moved and oriented to uniformly coat the tube profile. The containment enclosure is also scalable based on the size requirements for the tube.

Each spray point includes a transition block that mixes the air and liquid together and propels it onto the tube profile. The flat spray nozzles allow for a nearly continuous spray regardless of spraying upward, sideways, or downward. Systems with 4, 6, 8, and 10 spray points are available.



3.4 RESERVOIR

A 10-gallon gravity feed reservoir with sight gauge and low-level float switch for fluid monitoring ensures a continuous supply of fluid to the system. When the reservoir is low, a red light located on top of the HMI enclosure will flash. An 80-mesh strainer is provided to remove any particulate that may have inadvertently entered the reservoir. The strainer can be easily viewed from the outside and quickly cleaned or replaced as necessary. The reservoir and system controls utilize a shared T-Slot mounting frame. A 30-gallon reservoir is also available.

3.5 AIR WIPE (OPTIONAL)

An optional Exair Air-Wipe can be mounted to the spray containment box. This air wipe can be used to ensure the tube is both clean and dry before being coated. All controls, valves, and hoses are included. The integrated air wipe can be turned on and off through the HMI. A standalone air wipe with adjustable nozzles is also available.



4 SYSTEM FEATURES

HMI SCREENS

The HMI is the point of contact for an operator to set and adjust the system outputs. There are 6 different windows that can be navigated to using the tabs at the top of the screen.

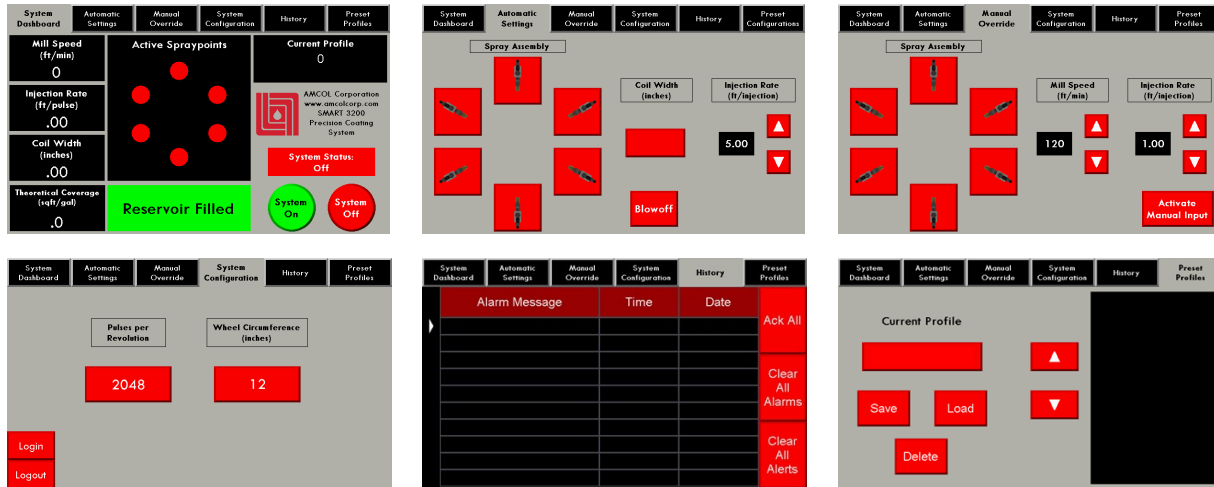

OPERATING MODES

The system has two operating modes:

- Automatic – Mill speed is calculated from the mill encoder. This mode should be used for normal operation. To use automatic mode, the encoder wheel circumference and pulses per revolution must be entered into the HMI.
- Manual – Mill speed is set by the operator. This should be used for installation, testing, and troubleshooting.

In the automatic mode, the coating of the profile can be modified by adjusting the number/location of active nozzles and the injection rate. Indicators on the HMI, lights on the solenoids, and active transition blocks are matched.

System settings can also be saved to custom reusable profiles for certain tube shapes, customers, or batches. 100 profiles are available for use. The active profile is displayed on the System Dashboard.

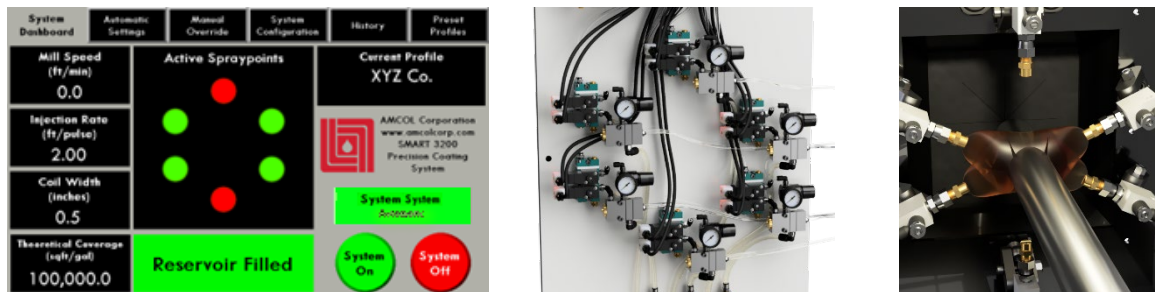

SPRAYBOX AND SPRAY POINTS

While the system is operating, individual spray points can be turned on and off to ensure complete and even profile coverage. The multi-functional mounting brackets, in combination with the rotating fan pattern of the spray tip, offer ultimate flexibility in customizing spray point locations for complex profiles.

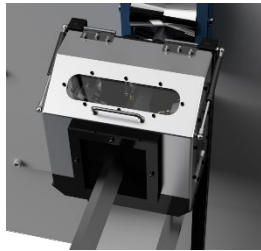

After setup and installation, simply close the spray box top over the tube. Foam pads are used to contain liquid in the spray box and should be cut to fit the tube profile. The top should always be closed while the system is operating to contain and collect any overspray.

SPRAY CYCLE

During the spray cycle, the dispersing air to a given spray point will always be on as indicated by the light located on the solenoid valve. The injector will cycle off and on as the other valve is energized and de-energized. This is an excellent way for a quick visual inspection that the valves are cycling as expected.

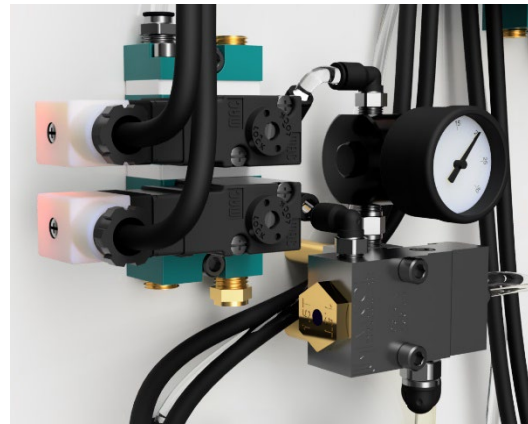

One injection from a T60A is comprised of two stages:

1. Injection stroke — Air pressure pushes the piston forward, and liquid pressure opens the evacuation check valve, displacing the liquid in the chamber.
2. Return stroke — Air pressure on the injector is exhausted, allowing the piston to spring return to the idle position, while also creating positive suction and refilling the piston chamber.

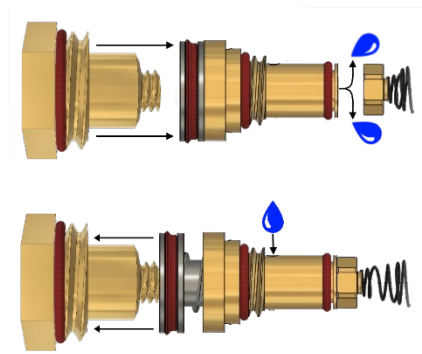

Output of each injector is based on the stroke length of the piston. With standard T60A injectors, this output can be modified with an adjustment screw on the hex cap. In order to provide repeatable coatings, each injector on the 3200S utilize fixed hex caps. These hex caps completely remove any adjustability to fluid output, which improves repeatability, fluid usage, and ease of use. T60A injectors on the 3200S output 1 gallon per 200,000 injection cycles (1.5T fixed hex caps).



LOW LEVEL INDICATOR

A low-level indicator mounted to the HMI enclosure will blink red when the reservoir is getting low to ensure the system never runs dry.



5 ALTERNATIVE OPTIONS & ACCESSORIES

5.1 SPRAY MOUNTING OPTIONS

Magnetic Rod Mount

Where there are space restraints or an existing spray box assembly is already installed, AMCOL offers a simple magnetic rod mounting system that can be quickly fixed to any location. Additionally, the modular design can be modified to fit a variety of special situations.



3200E Retrofit

There is also an option to fit the 3200S controls (PLC, HMI, and valve pack) to the older 3200E style spray box. An air blowoff valve controlled by the system is also included.

5.2 30-GALLON RESERVOIR

Standard 4, 6, & 8 injector 3200S systems come with a 10-gallon reservoir mounted to the back of the frame assembly. A 30-gallon reservoir is available for applications with high fluid consumption or less desired maintenance. The 10 injector 3200S system comes standard with a 30-gallon reservoir.

5.3 STANDALONE AIR WIPE – 3200S-AB-10

A standalone air wipe is available for customers who want separate control of the air blowoff or a more adjustable air wipe for large or varying profiles. This air wipe includes a lockout, regulator, and control valve, adjustable fan nozzles, and the adjustable mounting frame. A ½" air line and 24V DC electrical connection to the control valve is required for use. This accessory will consume approximately 45 CFM @ 20psi.



6 HOW TO ORDER

NUMBER OF SPRAY POINTS specifies how many transition blocks and injectors the 3200S system will have. This number should be chosen based on the maximum size of the tube and the desired coating weight. See the table for recommended configurations based on the maximum tube size.

Tube Diameter	Spray points
< 2"	4
2" – 3"	6
3" – 4"	8
>4"	10

SPRAY POINT MOUNTING specifies the type of spray point mounting. The standard spray box contains a complete package of transition blocks, containment, and mounting. The magnetic rod mount includes only the transition blocks and rod mount. The retrofit option should be selected when retrofitting 3200S controls to a 3200E containment box.

AIR WIPE specifies whether the system will include an integrated air wipe with a 5" inner diameter. The recommended clearance is at least ½" around the profile, so this setup can accommodate up to a 4" round profile, or up to a 3" square profile. This option includes all connections and controls to operate from the 3200S HMI. The standalone air wipe is recommended for larger profiles or if there are large variations in tube size.

3200S - X - YY - ZZ

X	Number of Spraypoints	YY	Spray Assembly	ZZ	Air Wipe
4	4 Spraypoints	CB	Standard Spray Box	—	No Air Wipe
6	6 Spraypoints	SP	Magnetic Rod Mount	A5	5" Diameter Air Wipe
8	8 Spraypoints	ES	Retrofit for 3200E		
10	10 Spraypoints	NC	No Spray Mounting		

SAMPLE SYSTEMS



3200S-6-CB-A5

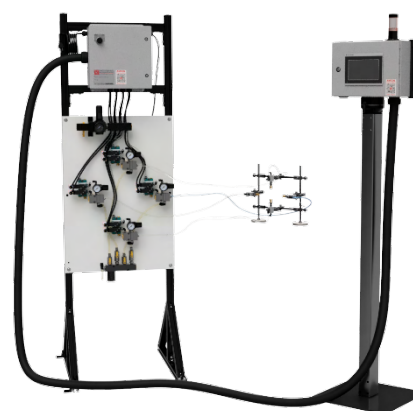

3200S-4-SP

7 ADDITIONAL INFORMATION

For information regarding installation, operation, and maintenance please refer to the AMCOL 3200S Operator's Manual.

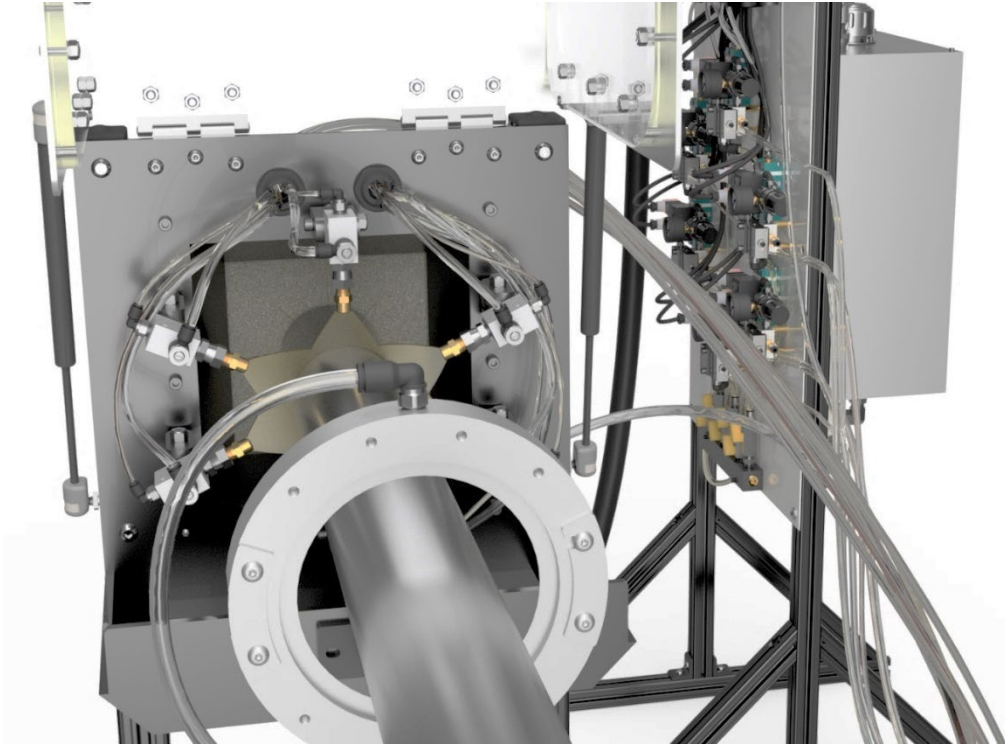

AMCOL Corporation

21435 Dequindre, Hazel Park, MI 48030

248-414-5700

fax: 248-414-7489

www.amcolcorp.com