

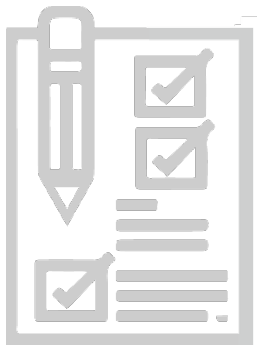

AMCOL CORPORATION
3063-HMA2 BILLET SPRAYER
WITH OVERSPRAY
CONTAINMENT



Contents

1 System Overview	2
2 Description of Components	4
Spray Assembly and Related Mounting	4
Valve Package	4
Liquid Reservoir	4
PLC Controls	5
Hose and Cable Assemblies	5
3 System Features	6
System Monitoring	6
Flow Monitoring	6
Fault Indicator	6
Easy to Install, Use, and Repair	6
034 Atomizer with 0.020" Flow Restrictor	7
Overspray Collection	7
Reservoir Circulation	7
Liquid Air Purge	7
System Durability	8
4 Recommended Fluid	9
5 How to Order	9
6 Additional Information	10



AMCOL Corporation

21435 Dequindre, Hazel Park, MI 48030	248-414-5700	fax: 248-414-7489	www.amcolcorp.com
---------------------------------------	--------------	-------------------	--

1 System Overview

The AMCOL Model 3063 spray systems were first introduced in the early 1990s for use in aluminum extrusion. At the time, the industry was transitioning from precut billets and loose dummy blocks to hot sheared billets and fixed dummy blocks. AMCOL was on the forefront in the development of automatic billet and dummy block spray lubrication systems.

The AMCOL Model 3063 spray systems incorporate a rotating spray head designed to apply a water-based water, dilutable, release agent. These systems are scalable with changes to the spray tube length to accommodate various diameters. An air pilot operated atomizer feeds liquid and air to the rotating spray head. The result is a light, even, round spray pattern.

The 3063-HMA2 Billet Sprayer with Overspray Containment is our newest evolution to these systems and includes the standard features of traditional 3063A BSR systems, as well as several dramatic improvements, including:

- Flow Monitoring of Liquid Output
- Overspray Containment and Collection
- Independent Programmed PLC to Ease Installation and Operation
- Alarms to Communicate Issues with Fluid Output and Level

The spray head and related mounting/containment is located where the billet will stop. When the billet is in position, a single source pulse will initiate the complete cycle. The spray head will move forward. When the spray head reaches the billet end, a magnetic reed switch on the cylinder initiates the spray cycle. Air is turned on and the spray head begins to rotate. Liquid is turned on to feed the spray head. Air continues afterwards to clean out the rotating spray assembly. The cylinder is then retracted so that the billet can be moved to the press.

Any spray that does not adhere to the billet is directed down through a chute on the bottom of the spray head. A tray is strategically located to collect any fluid that drains down, whether the spray head is in the dormant position or in the active spray mode. This tray is easily removed for subsequent cleaning.

There is a magnetic reed sensor on the retracted side of the cylinder used to move the spray head. This sensor is tied back to the press PLC to see that the transveyor or loader is not moved without the spray head out of harm's way.

The spray head mounting assembly is adjustable in all directions to ensure the spray head is centered, square, and close to the billet. The tray is also adjustable up and down to account for a variety of billet manipulating systems. Maximum height for a standard system is 52", floor to center.

The 46ILX EJECTEZE used in this system is a water based organic coating that is diluted with 3-parts water to 1-part concentrate. At this dilution, a solid film coating is left behind as the

water instantly evaporates. For billet spray, the typical consumption on an 8" diameter billet is less than 1.25 gallons of concentrate per 1000 billets.

AMCOL Model 3063-HMA2 Spray System is meant to be easy to install and start operating with limited manpower required to wire, program, and interface with the press PLC. The system operates using clean dry plant air, a 110V AC receptacle to power the system PLC controls, a control signal output from your press PLC, and an input to the press PLC to ensure the spray head is out of harm's way when the loader is moving. Connections are available to communicate with the press PLC but are not required. No programming or other wiring is necessary.

AMCOL 3063-HMA2 Spray Systems is the result of years in the making. It incorporates a long list of user-friendly, reliability-driven features.



Simply put, there is no better system on the market!

2 Description of Components

Spray Assembly and Related Mounting

The 3063-HMA2 spray system utilizes four rotating spray tips at different diameters. This rotating spinner nozzle is chain driven using a brushless sealed servo motor. The result is a consistent, even, and known rotation. The 034 Atomizer used to feed liquid and air to the spinner nozzle has a flow restrictor (fixed orifice) to throttle liquid output. The flow monitor is integrated with this assembly just prior to the 034 Atomizer. T-slot mounting makes it easy to locate the spray head to be square and centered on the billet. The overspray collection tray located below the spray head is also easy to position. A robust dual rod cylinder, cushioned on both ends, is used to move the spray head back and forth quickly and efficiently; magnetic reeds are used to locate the cylinder position.



Valve Package

The valve package includes liquid and air valves to service the spray head, air cylinder, and liquid air pump. These valves are connected to the system PLC, so no wiring is required. The valve pack also includes a lock and tag shutoff for the entire system and an 80-mesh liquid strainer. All that is required to install the valve pack is a clean, dry, 1/2" NPT air source.

Liquid Reservoir

The liquid is supplied from a stainless-steel reservoir using an air operated double diaphragm pump. Liquid pressure is set with an air regulator located prior to the pump. A ball valve on the liquid output opens a bypass that returns fluid through a mesh strainer back into the reservoir, keeping the pump and liquid always in motion. This same strainer will filter any liquid that is circulated to and from the atomizer. A low-level float switch and external sight level gauge allows for monitoring of the fluid level in the reservoir.



PLC Controls

An independent Electronic Timing Controller (ETC) manages all aspects of the system. This PLC is preprogrammed to ensure proper valve sequencing. The display on the outside of the enclosure can be used to adjust cycle settings and view faults. All that is required to install is a 110V AC receptacle, a 24V DC control signal to initiate the spray cycle, and 24V DC input to communicate with the press PLC when the spray head is in the home position. Additionally, there is an open connection for the fault light that can be accessed and wired to the press PLC, if desired.



Hose and Cable Assemblies

Fire resistant hose with union and JIC fittings are included to connect the various air connections from the valve package to the spray head. Clear urethane tube is used to connect the liquid lines for ease of viewing from the valve pack and reservoir to the spray head and are wrapped in a fire-resistant wrap to further protect the lines. All cable and wire connections from the spray head are also wrapped for protection and easy management.

Standard hose lengths from the spray head to the reservoir and valve pack start at 10' and can be as long as 36'.



3 System Features

The AMCOL 3063-HMA2 Billet Sprayer with Overspray Containment system includes all the standard design features of traditional 3063 systems, while also making several improvements to further increase system reliability, longevity, and effectiveness.

System Monitoring

Flow Monitoring

To ensure that the billet is coated every time, the 3063-HMA2 utilizes an ultrasonic flow meter that surrounds the liquid line to the 034 atomizer. This meter is connected back to the ETC to confirm positive output. A light on the meter will turn green when flow is occurring, and a flow output can be read on the door of the ETC.



Fault Indicator

An indicator light mounted on the top of the enclosure will flash when the reservoir is low, flow is not detected during the spray cycle, the cylinder is not properly cycling, or the motor is not rotating. This light will continue to flash until the error is cleared on the display. Additionally, the display will turn red, and a fault message will be displayed on the main screen. Open terminals inside the ETC that can be tapped into and wired to the press PLC to monitor the status of the indicator light.



Easy to Install, Use, and Repair

The AMCOL 3063-HMA2 Spray System has been specifically designed to be an easy to use, drop-in solution.

The floor mounted reservoir now integrates the valve package and ETC in one assembly. The top of the reservoir is removeable for ease of cleaning.

The mounting frame assembly for the spray assembly is constructed out of aluminum T-Slot, which provides a sturdy frame that is easily adjusted. The spray head can be adjusted in all directions by loosening the screws, moving the T-Slot, and retightening the screws. The mounting feet also provide an easy solution for floor mounting.

The prewired ETC makes installation easy and ensures proper cycle timings. Through the screen and button interface, the system status and timings can be easily viewed and adjusted if necessary. The system can also be manually cycled for testing and troubleshooting.

All the valves are installed to be easily replaceable. The spray containment cover can be quickly removed for full access and viewing of the spinner nozzle. The 034 Atomizer can be manually disassembled and rebuilt.

034 Atomizer with 0.020" Flow Restrictor

The air pilot operated 034 atomizer is at the heart of this system. A nonadjustable 0.020" orifice flow restrictor is used to meter the liquid output. The flow restrictor's micro port atomizes the liquid and air as it is forced through it. When the air piloted piston is opened, liquid is allowed to travel through the flow restrictor and into the air stream. This air pilot operated atomizer also serves as a liquid shutoff at the point of dispensing. The small, atomized particles adhere better to hot surfaces, and the volume of fluid output is strictly controlled, allowing for known, consistent fluid consumption.

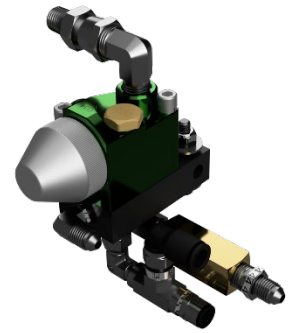

Overspray Collection

To reduce nearly all overspray, the spray head of the 3063-HMA2 system moves in and nearly touches the billet through the use of a small air cylinder. By moving the spray cover as close as possible to the billet, nearly all of the overspray is contained. A chute in the bottom of the spray cover allows for excess fluid to drain down into the collection tray below. This tray can be easily emptied and cleaned.



Reservoir Circulation

The use of a diaphragm pump allows for a consistent pressure at the spray points, as well as the ability to mix and dilute the billet coating fluid inside the reservoir. Using the fluid recirculation valve on the reservoir, flow to the reservoir and pressure at the spray head can be adjusted. By keeping the valve slightly open, fluid can be constantly recirculated back to the reservoir while still maintaining a consistent pressure at the spray head.

Liquid Air Purge

Consistent and uninterrupted fluid flow is crucial to the operation of 3063 systems and their ability to provide a thin coating on the billet or dummy block. If an air pocket builds inside any of the liquid lines and is allowed to travel to the spray points, the flow could be momentarily interrupted. Since 3063 systems use low volumes of fluid, this could severely impact the system's ability to operate consistently. To combat this, a liquid air purge has been built into the system. Liquid can be manually cycled from the reservoir, through the

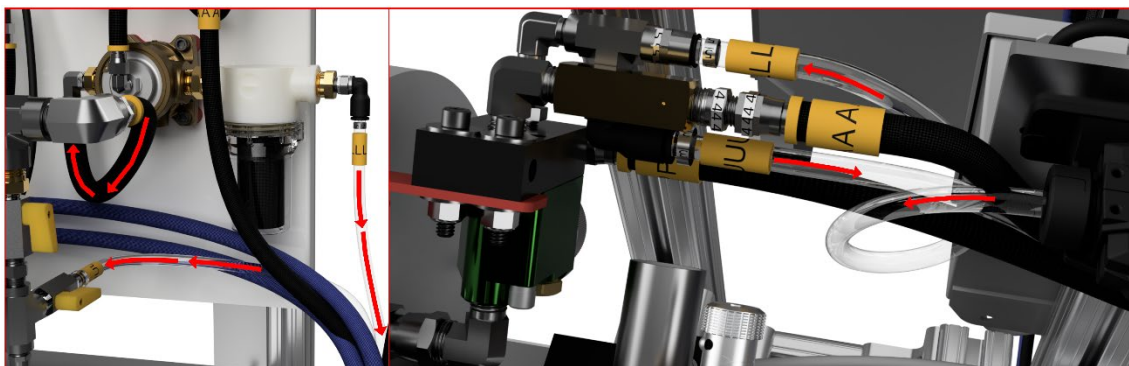

valve package, to the atomizer, and then back to the reservoir. This operation allows for the complete removal of any air in the liquid lines of the system.

System Durability

The moving components in 3063-HMA2 spray heads have been designed with longevity and durability in mind, reducing the downtime required for replacing broken or worn-out parts.

The spinner bodies are made of stainless steel to improve chemical resistance and are precision machined to ensure that each spinner functions exactly as it should. They utilize sealed bearings to remove the need for relubrication and to keep debris out of the bearings. This keeps the assembly spinning smoothly without worry of failure. They are also completely leak free, as each spinner has a triple seal preventing any leaks.

The spinner assembly is driven using a sprocket and chain assembly that is connected to a fully sealed, IP67 rated brushless servo motor. The sprocket and chain assembly are used to decrease the rotational speed of the spray assembly, which allows the spinner to rotate slower for a more consistent and effective coating.

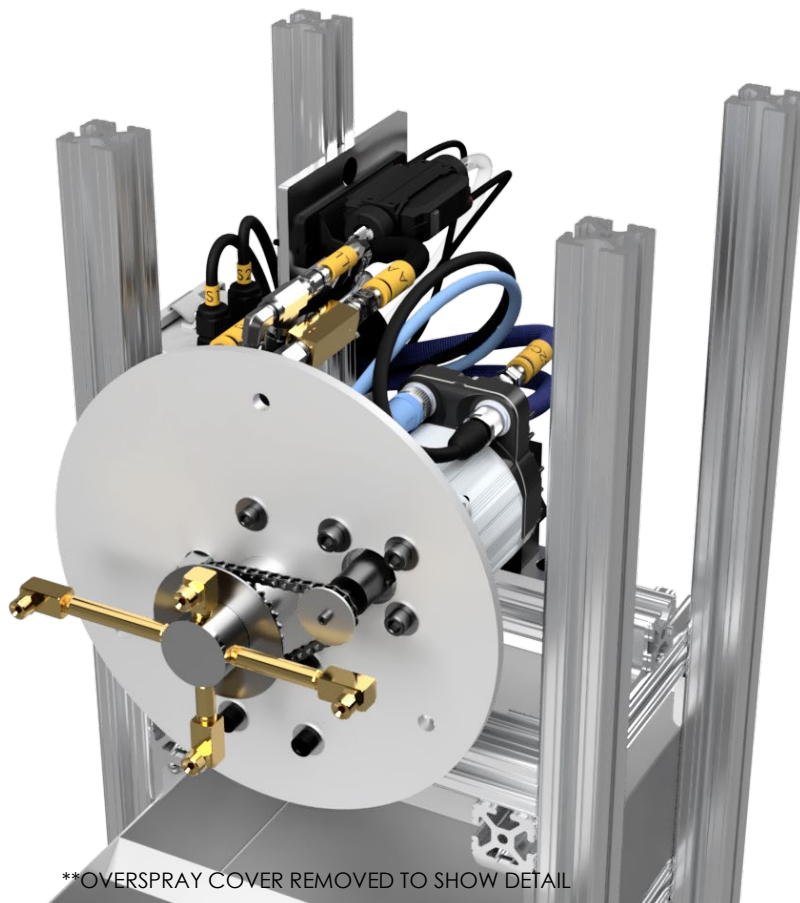

**OVERSPRAY COVER REMOVED TO SHOW DETAIL

4 Recommended Fluid

46 ILX EJECTEZE

46 ILX EJECTEZE is a medium viscosity, water miscible fluid concentrate used to reduce metal build-up of non-ferrous metals onto hot tool steels used in the extrusion process. When used in combination with AMCOL's 3063-HMA2 system, aluminum build up and sticking will be reduced without affecting the finished material. The minute quantity sprayed by using the system also makes 46 ILX EJECTEZE a cost-effective solution when compared to messy and unsafe alternatives.



5 How to Order

3063-HMA2-#

(# = BILLET DIAMETER IN INCHES)

Additionally, specify:

- Billet Height: Distance from floor (or mounting surface) to center of billet
- Hose and Cable Length from controls to spray assembly (10', 16', 20', 26', 32', or 36')

To place an order or if you have any further questions, please contact your AMCOL sales representative or contact AMCOL directly by:

- Email – orders@amcolcorp.com or info@amcolcorp.com
- Phone – (248) 414-5700
- Fax – (248) 414-7489

6 Additional Information

For more information regarding installation, operation, and maintenance of 3063-HMA2 systems, please refer to the AMCOL 3063-HMA2 Billet Sprayer with Overspray Containment Operator's Manual.

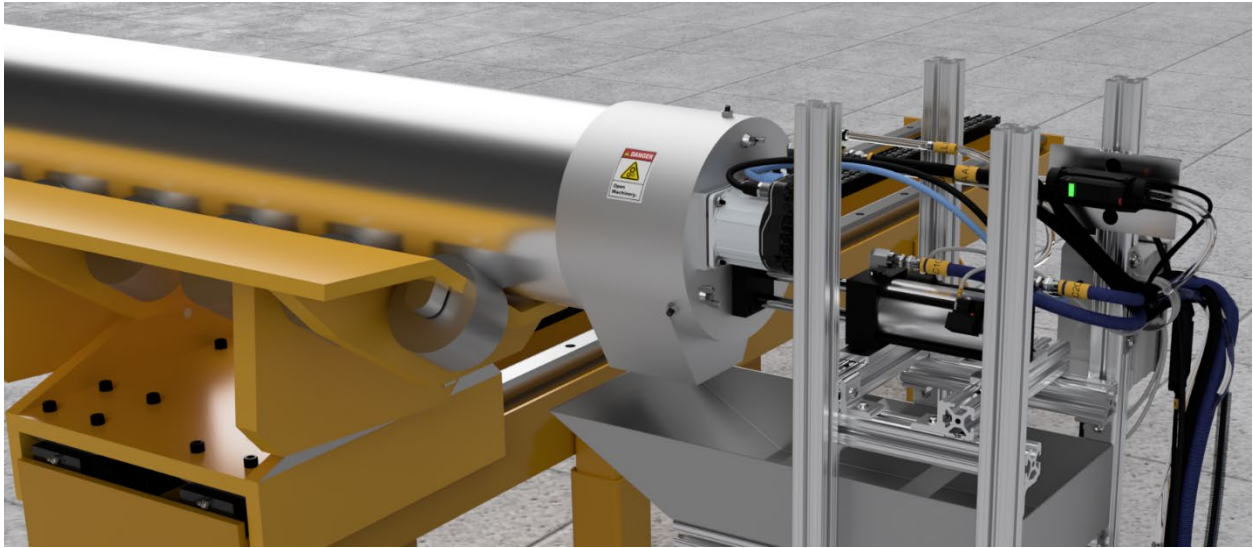

AMCOL
Corporation



3063-HMA Support



AMCOL Corporation

21435 Dequindre, Hazel Park, MI 48030

248-414-5700

fax: 248-414-7489

www.amcolcorp.com