



AMCOL Corporation

Proven technology, refined over decades.

Lubrication Technologies for
Aluminum Extrusion and Casting

Why 6000E and CANMIST for **Sawing Aluminum?**

AMCOL 6000E Precision Lubrication with SMART Controls

- **Measurable** - Electronic Volume Control
- **Repeatable** - No Adjustments in the Control Box
- **Reliable** - Fixed Piston Stroke Injector,
Fixed Atomizing Air Pressure
- **Precise** - Spray Nozzle Manifolds Designed to
Surround the Blade and Penetrate the Cutting Edge

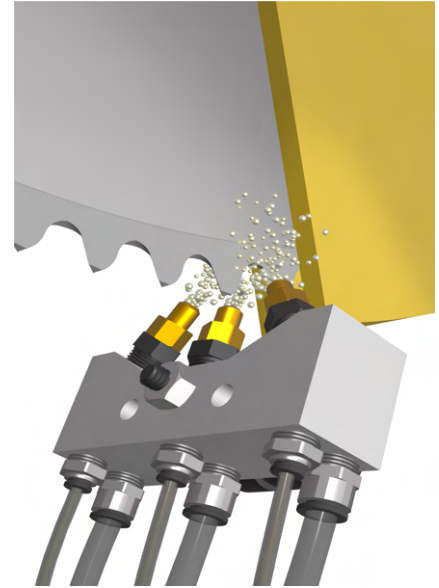
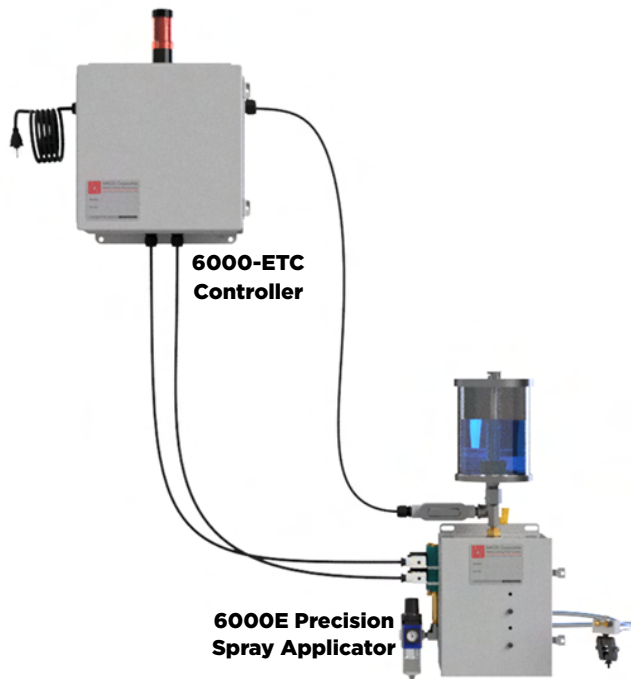

The Result:

- **S**ystem settings are exact and repeatable.
- **M**aximum tool life. Minimum lube usage.
- **A**ddjustments made easy.
- **R**educe smoke, mist, and overspray.
- **T**otal control of pump frequency.

Lubrication wouldn't be **SMART**
without **CANMIST** cutting fluids.

AMCOL offers a variety of CANMIST products
to meet your price and performance needs.

**CANMIST
Lubricants**





AMCOL Corporation

Proven technology, refined over decades.

Lubrication Technologies for Aluminum Extrusion and Casting

Reduce Consumption by Pairing **SMART 6000E** with **CANMIST** Saw Lubricants

CANMIST Series Lubricants



HD - Excellent Cut Quality

- Heat Treat Compatible
- Non-Freezing
- Blue Color



390 ND - Minimum Burr on Tough Profiles

- Will Not Stain in Heat Treat
- Non-Freezing
- Maximum Blade Life



331 WLX - Water Washable

- Gold Standard for Hot Billet Sawing
- Low Smoke, Low Mist
- Ideal for Fabricating Extrusions



357 HD - Low Smoke in Heavy Cutting

- Heat Treat Compatible
- Excellent Performance and Value
- Light Oily Residue

6000E Smart Features

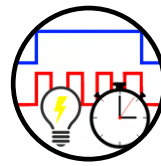

Electronic Fluid Injection

- Repeatable Volume Output
- Eliminate "Eyeball" Adjustments
- Programmed Into the PLC



Fixed Atomizing Air Pressure

- Eliminate Mist or Fog
- Optimized for Sawing Environment
- Available Options: 10 and 15 PSI



Fixed Piston Stroke Length

- Consistent Liquid Volume
- Repeatable Results
- Available in 3 Stroke Length Options



AMCOL Corporation
 21435 Dequindre
 Hazel Park, MI 48030
 248-414-5700
 fx. 248-414-7489
www.amcolcorp.com
 Aluminum CANMIST+6000E FB02
 Approved for Use
 LSB: AA0014
 LSD: 02/19/2026