

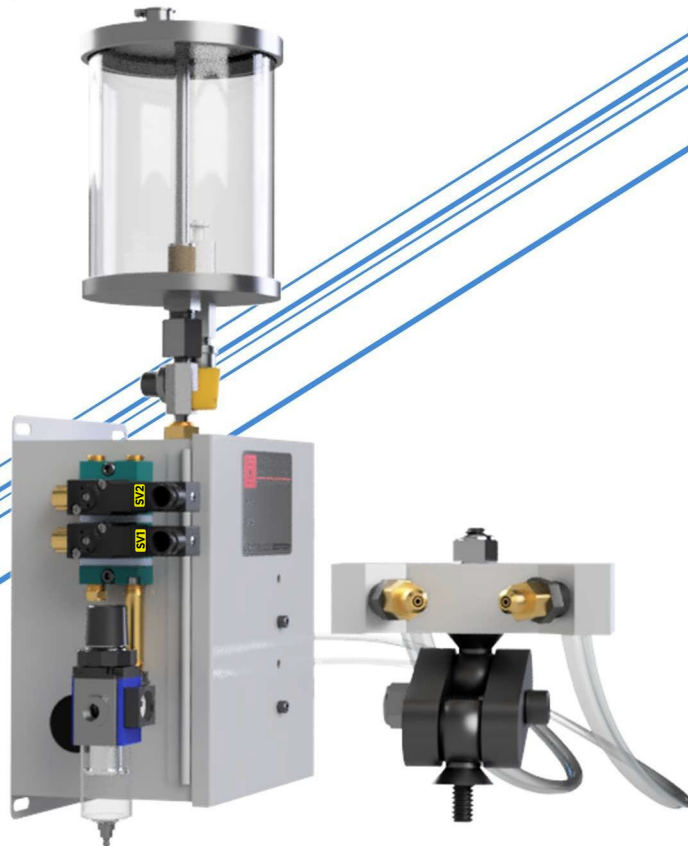

AMCOL CORPORATION
6000E ELECTRONICALLY
CONTROLLED PRECISION
LUBRICATION SYSTEM

Technical Description



Contents

Introduction to Precision Lubrication and 6000E.....	2
The AMCOL Model 6000E – System Overview	3
T60A Posi-pump Injection Meter	4
General Overview	4
Injection Cycle.....	4
Volume Control	5
Timing of the Solenoids.....	6
Model 6000E in Detail	7
<i>System Controls – Description and Options</i>	7
<i>System Controls with SMART Metering</i>	8
Gravity Feed Reservoirs.....	9
Air/Liquid Hose to Spray Point.....	11
Air/Liquid Spray Assembly.....	12
How to Specify Your 6000E.....	13
Sample Systems.....	15
Air/Liquid Spray Assemblies.....	16
Single-point Transition Blocks	17
Multi-point Spray Assemblies for Saws.....	16
Addons	18
Complex Systems with Multiple Posi-pumps	19
6000-ETC Electronic Timing Controller	20
AMCOL CANMIST High Performance Lubricants.....	21



AMCOL Corporation

21435 Dequindre, Hazel Park, MI 48030	248-414-5700	fax: 248-414-7489	www.amcolcorp.com
---------------------------------------	--------------	-------------------	--

Introduction to Precision Lubrication and 6000E

AMCOL was on the cutting edge in the late 1980's when it introduced the world to precision lubrication for machining and fabrication of metal. Also known as Minimum Quantity Lubrication (MQL), precision lubrication utilizes extremely accurate spray systems to dispense high-performance synthetic lubricants to the cutting tool or work piece. The result is near dry metalworking with maximum tool life. This technology has replaced a long list of now outdated lubrication and coating methods that include recirculating flood, pressurized spray, venturi spray, high pressure low volume (HPLV), airless spray, drip, and others.

The AMCOL 6000 Series Precision Applicators and CANMIST High Performance cutting oils have set the industry standard in this continuously evolving technology. Simply put, we offer the most versatile range of lubricants and applicators on the market today.

For years, our spray systems have been on the cutting edge with a variety of unique design features that are user friendly and performance driven. Included with every 6000 Series Applicator are the following:

- ✓ T60A Posi-pump – A patented self-priming injector with fluoroelastomer seals that last for 10's of millions of cycles. Injectors are manifolded to eliminate stacking.
- ✓ Pressure (not flow) Regulated Spray – For instant air at the spray point, that can be gauge set and observed at the control box. Our competitors control spray pressure with a flow control that is randomly set and slow to reach the spray point.
- ✓ Biaxial Liquid and Air Delivery – Liquid and air travel side by side to the spray point. This design feature replaces the now outdated coaxial system that is commonly employed by our competitors. Biaxial hose makes installation, repair, and maintenance a breeze. Application specific hoses are also an option.
- ✓ Spray Tips and Mounting Systems Galore – AMCOL 6000 Series Precision Applicators are available with the most diverse set of options to meet your exacting need. We have manifolds for circular saws, spray assemblies for band saws, through the tool connection systems, and many more.

AMCOL is now introducing the world to the next evolution in precision lubrication. The Model 6000E with electronic control of injection rate replaces the pneumatic pulse frequency generator with a solenoid-controlled air valve. The technology was originally introduced for applications with extremely high cycle rates where pneumatic timing simply could not keep up. More recently, this technology is now being used in virtually all applications.

The AMCOL 6000E Precision Applicator provides ultimate control of cycle timing during the machine cycle. Many prefer to control injection rate with the machine PLC. This eliminates random setting and gives you ultimate control. AMCOL also offers an independent electronic timing controller for those with limited PLC capability.

This document will guide you through the major assemblies and options. It should be used to better understand which options are best for your application and to create a system that is custom fit to your production needs.

The AMCOL Model 6000E – System Overview

The AMCOL 6000E Precision Applicator is the most recent evolution in the 6000 Series. As with all 6000 Series Spray systems, liquid is gravity fed to positive displacement pumps that injection meter liquids. Air and liquid travel side by side to the spray point where they are mixed and dispensed. Pressurized air is used to propel the liquid from a spray tip. Multi-point lubrication is accomplished with multiple injectors. Up to 5 injectors can be manifolded to operate in unison.

The AMCOL 6000E Precision Applicator controls injection rate with a 3-way electric air solenoid valve. Injection cycle rate is set and adjusted by your machine PLC. This allows precision adjustment and eliminates randomness of setting pulse frequency generators. If your application does not allow for PLC integration, AMCOL offers the 6000 ETC independent timing controller.

A second 3-way electric air solenoid valve is used to control dispersing air pressure. Both valves unified with a stacking design so that only one air input is needed for the system.



Systems include a control box, liquid reservoir, air/liquid hoses to the spray point, and a spray assembly for mixing and dispensing the liquid. A representative system is shown with the control box open and closed. This system has a control box with two injector Posi-pump that is supplied using a ½ gallon reservoir with a low-level indicator. The spray assembly is an AMCOL B2 Saw Manifold with a Compact Multifunctional Mount.

We offer a myriad of options to meet your exact requirements.

T60A Posi-pump Injection Meter

General Overview

The T60A Posi-pump is at the heart of every system. The T60A Posi-pump is a positive displacement pump used to meter liquids. Each injector is installed in an extruded housing that has an air inlet and liquid inlet. Multiple injectors can cycle in unison while being fed from the same liquid source. Up to 5 injectors can be in one Posi-pump assembly. The image shows a T60A Posi-pump with two injectors: one injector is shown with an exploded view to see the internal components.

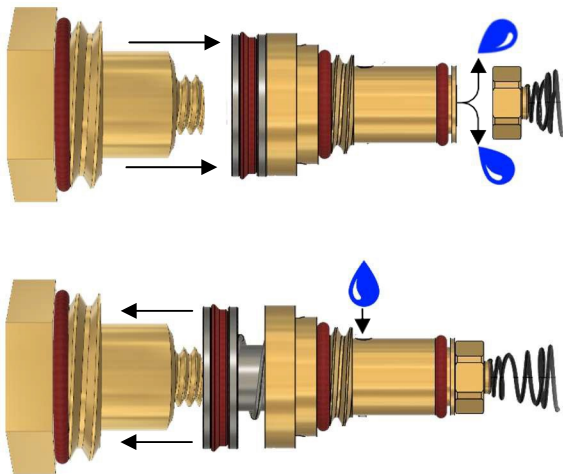
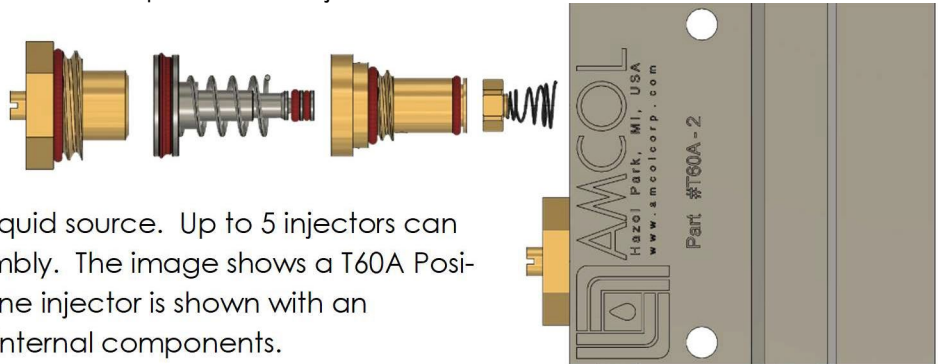

Injection Cycle

The cycle is completed in two stages:

1. Injection Stroke – Air pressure pushes the piston forward, liquid pressure opens the evacuation check valve, and the liquid is displaced from the chamber.
2. Return Stroke – Air pressure on the injector is exhausted and the piston is spring returned to the idle position while at the same creating positive suction and refilling the piston chamber.

Volume Control

Output per injection cycle is based on the stroke of the piston. The longer the stroke length, the more fluid that will be dispensed. There is an adjustable screw that can be rotated to set the stroke length. Rotating the adjustment stem clockwise shortens the stroke length. Zero output is achieved by rotating the adjustment screw clockwise until it bottoms out.

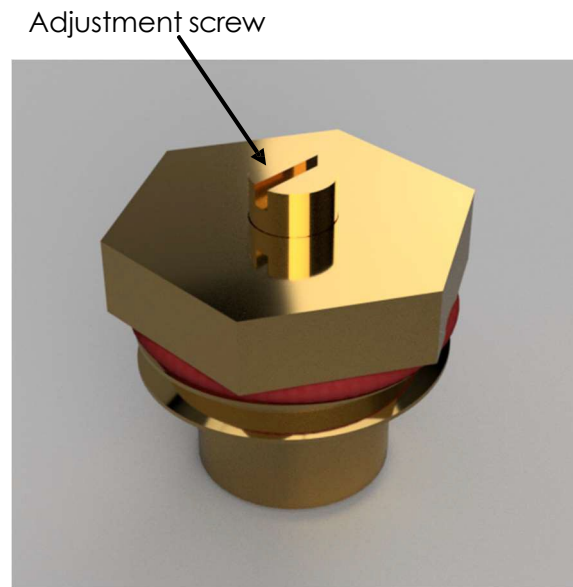
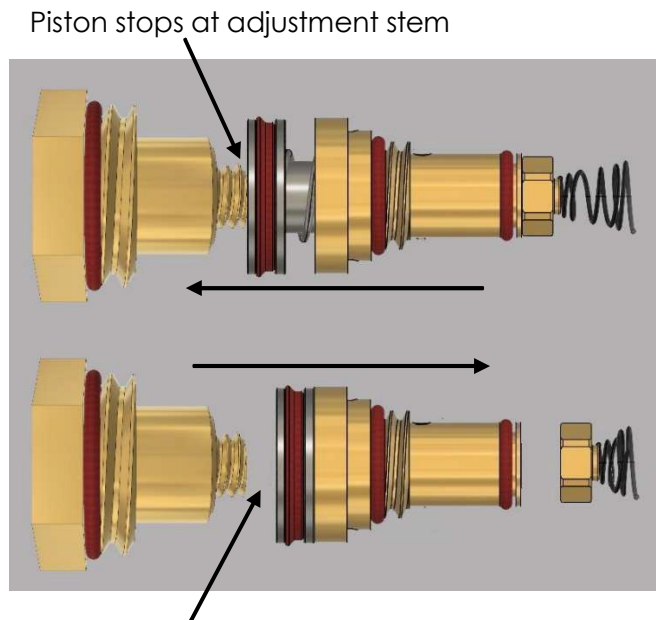

Stroke length

T60A Hex Cap with Adjustment Stem

Top: Piston is in the home position
Bottom: Piston in output position

For users that want to limit the ability of personnel to make random changes to the injector setting, AMCOL offers fixed position injectors where the stroke length is not adjustable. With this option the output is controlled completely based on injection rate. The faster you cycle, the more liquid that is dispensed. The setting for the hex cap is identified as shown. Many fixed output volumes are available to accommodate specific operations. (1.5T = 1 1/2 screw turns counterclockwise from the closed position)

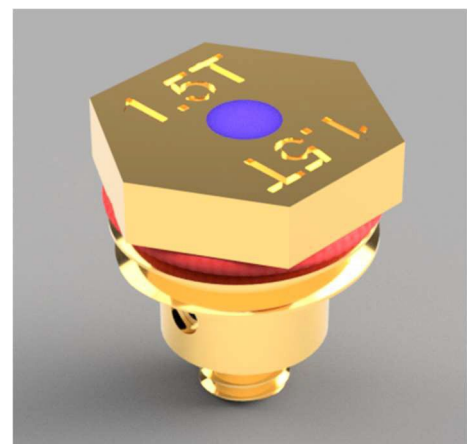

T60A Hex Cap with Fixed Output to 1.5T

Timing of the Solenoids

The cycle rate of injectors is controlled using a normally closed 3-way electric air solenoid. When a signal is applied to the solenoid, air pressure is turned on and the injector cycles forward. When the signal is removed, pressure on the piston is exhausted from the 3-way valve and the injector returns to the idle position.

The injection timing valve and dispersing air valve are stacked together so there is only one air connection to your system. Systems require two electrical signals, one to control each valve. A typical timing sequence for both valves operating together during a spray cycle is shown; note that the Dispersing Air Valve (SV1) is energized for the complete spray cycle time (T1) and the Injection Rate Air Valve (SV2) is turned off and on at with a pulse rate of T2.

The T60A Posi-pump can cycle up to 10 times per second – 20 milliseconds for the injection (dispensing) stroke + 80 milliseconds for the return stroke (refills the injection chamber). The injection rate at 10 times per second would equal 100 milliseconds (T2).

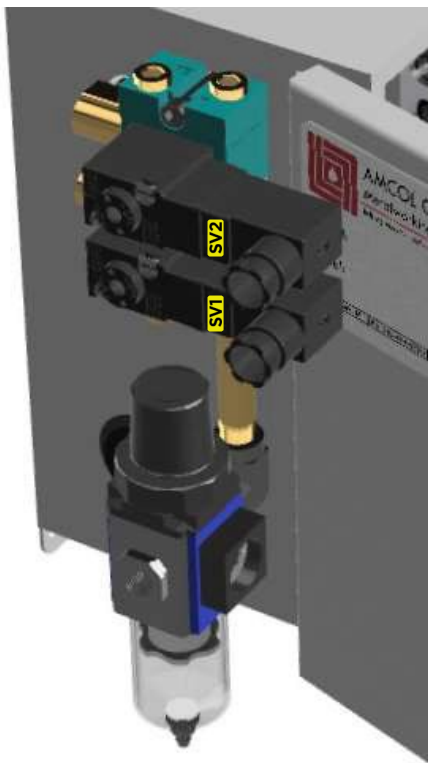

Two Solenoids with Filter Regulator

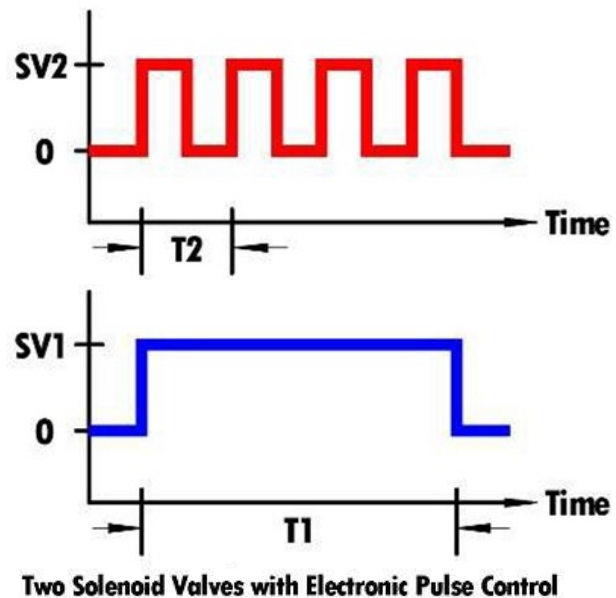

Typical Solenoid Timing Sequence

Model 6000E in Detail

Four assemblies complete a spray system.

- ✓ System Controls
- ✓ Gravity Feed Reservoirs
- ✓ Air/Liquid Hose to Spray Point
- ✓ Air/Liquid Spray Assembly

System Controls – Description and Options

Simple systems will have all injectors operating in unison. The controls are mounted to a steel enclosure and include:

- 3-Way Electric Air Solenoid Valves –** Two valves are stacked together. One controls fluid injection rate and the other controls spray point dispersing air. A system air filter/regulator is included.
- Posi-pump –** Each T60A Posi-pump houses up to 5 injectors that cycle together. Stroke length can be adjustable or fixed.
- Dispersing Air Supply –** An air regulator to set dispersing air pressure is connected to a manifold so that there is one air output for each injector. The air regulator can be specified to be preset and non-adjustable for applications with a known set point; this avoids random setting that leads to mist and fog.
- Tube and Fittings to Interconnect –** Air is shown in green and liquid in blue.

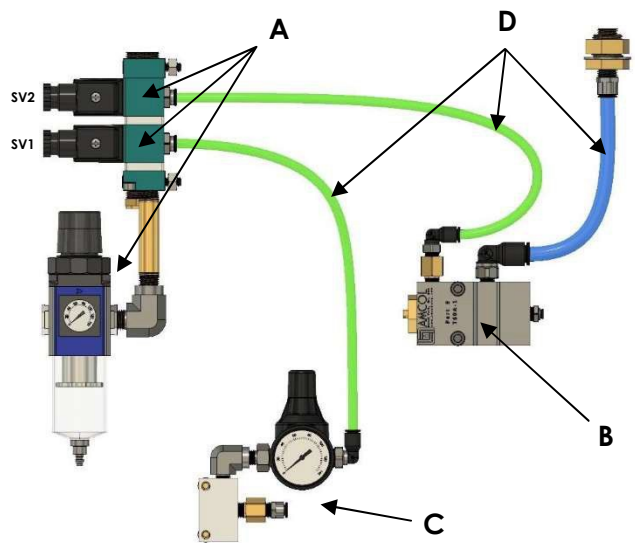

A representative control box with two injectors is shown.



System Controls with SMART Metering

A SMART Control Box will have electronic control of injection rate, fixed stroke injectors, and a preset dispersing air spray pressure regulator. Your only system adjustment is injection cycle rate. We call this SMART Metering. SMART metering is best when compared to the old-style injection metering systems with a Pulse Frequency Generator.

SMART metered systems include the following:

1. **PLC Control of Injection Pulse Rate**
2. **Fixed Position Injection Volume per Stroke**
3. **Pre-Set (Non-Adjustable) Spray Tip Pressure**

SMART systems are truly the next generation in Precision Lubrication Technology. Put the control in your PLC!

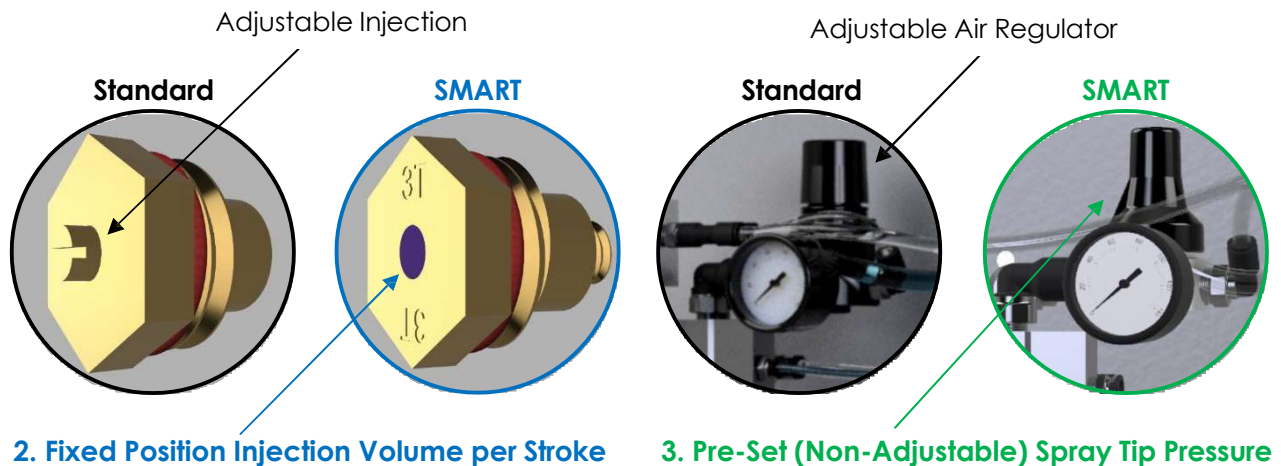
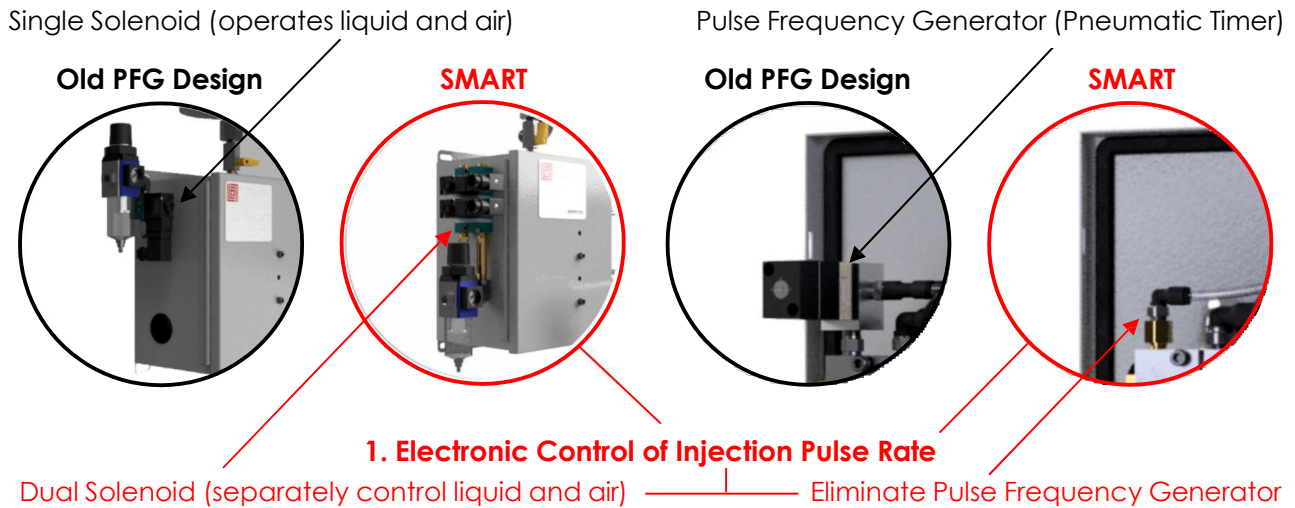

Gravity Feed Reservoirs

Reservoir size and capacities vary according to customer needs. Smaller reservoirs are available to meet space and budgetary constraints. Larger reservoirs extend filling intervals.

There are two types of reservoirs that supply liquid to the injectors.

- Small Capacity – These reservoirs are connected directly to the top of the system control box using a threaded pipe fitting. Two sizes of small capacity reservoirs are available: A ½ gallon reservoir is available with and without a low-level switch. A smaller 10-ounce reservoir is available when space is limited. All reservoirs include an internal mesh strainer to remove larger solids thus protecting the injector.

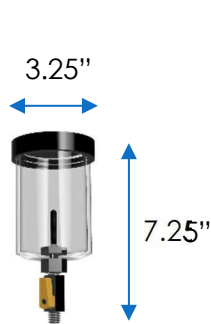

10 oz. Reservoir



1/2 Gallon Reservoir

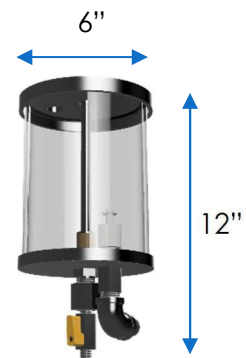

1/2 Gallon Reservoir with
Low Level Indicator

Large Capacity – These stainless-steel box style reservoirs are available in 2.5, 5, and 10-gallon capacity. They are wall or machine mounted using the eyelets located on the backside corners. A sight level gauge allows for quick and convenient viewing of liquid level in the reservoir. A filler-breather with a mesh strainer is used for quick, easy filling and prevents contamination after filling. An in-line, 80-mesh strainer bowl is included on the exit side of the reservoir. This allows for easy viewing of liquid condition and can be quickly changed out when it becomes contaminated. All large capacity reservoirs include an option to add a low-level float switch (A). All reservoirs include a ball valve that can be shutoff to service the injectors or replace the in-line mesh strainer.

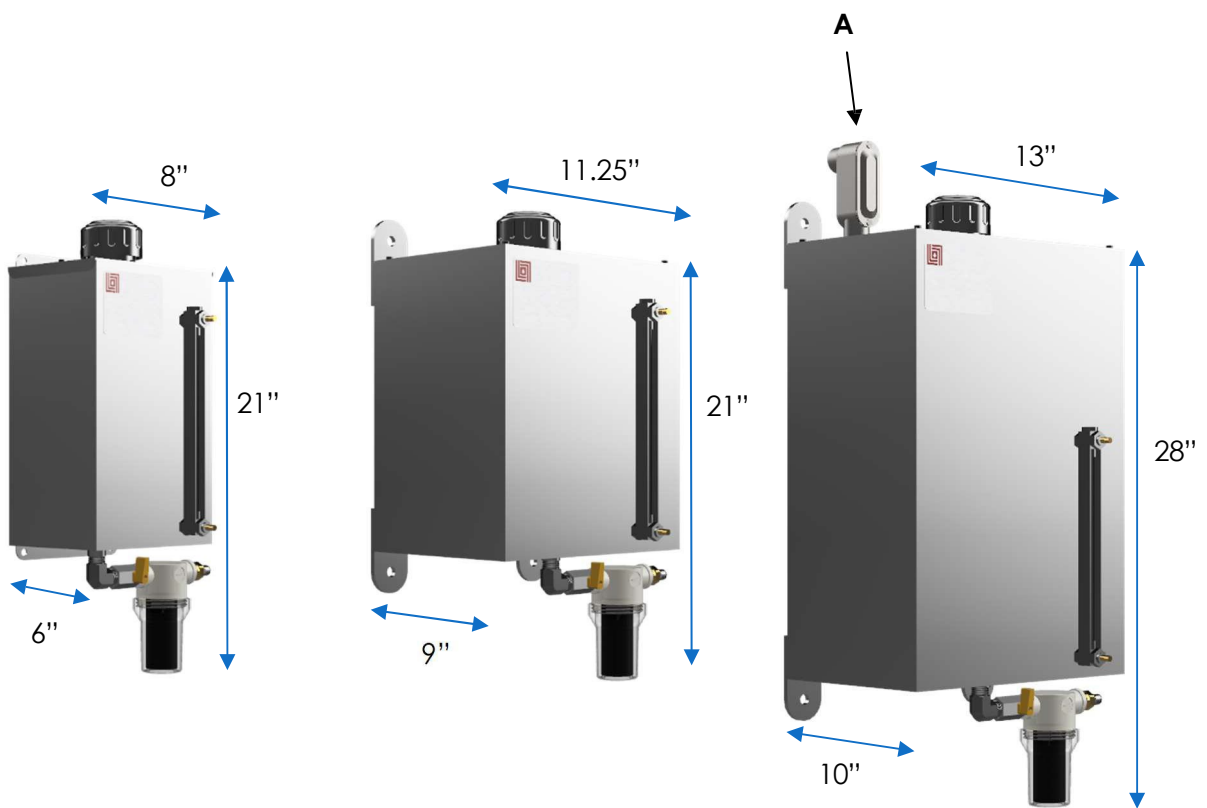

2 1/2 Gallon Reservoir

5 Gallon Reservoir

10 Gallon Reservoir with Low Level Indicator

Air/Liquid Hose to Spray Point

Biaxial hose is a unique design used to carry liquid and air side by side to the spray point. The air hose is 1/4" OD and liquid hose is 1/8" OD. There are three types of biaxial hosing:

- Urethane Bonded – This is the standard recommended option as the hoses are flexible, quickly cut-to-length, and available in a variety of colors to match spray points with injectors. 10 feet of biaxial hose will be included per injector and additional hose is optional.
- Bonded and Recoiling – Hoses are form coiled. This type of hose is used where the spray point is moving and so the coil can be stretched back and forth. Hose is supplied in 10-foot segments. Hoses can be joined in series with a splicer kit for applications requiring longer coiled hoses.
- High Temp PTFE – This hose is recommended for applications involving high temperature (up to 500° F) and high wear. Air and liquid hoses are connected using clamps. Hose is relatively rigid and thus is not recommended where flexibility is desirable. Hose length is also limited, but can be coupled using a splicer kit.

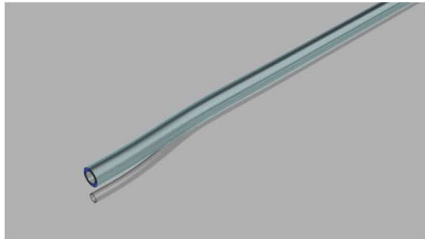

Urethane Bonded Biaxial
Hose

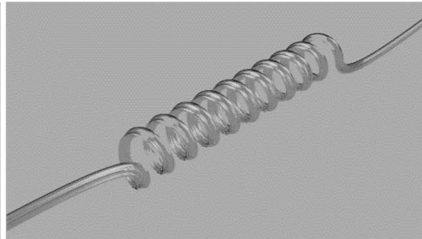

Bonded Recoil Hose



High Temp PTFE Hose

Air/Liquid Spray Assembly

Air and liquid are mixed at the spray point. The air is pressure regulated and used as a propellant to spray the liquid onto the tool or workpiece. There are single point spray blocks and multipoint manifolds for saws. Mounting systems can be included to ease installation and repair.

Single point spray assemblies bring liquid and air together as shown.



Transition Block with Low Profile Flow Control and Air Propelled Wet Tip

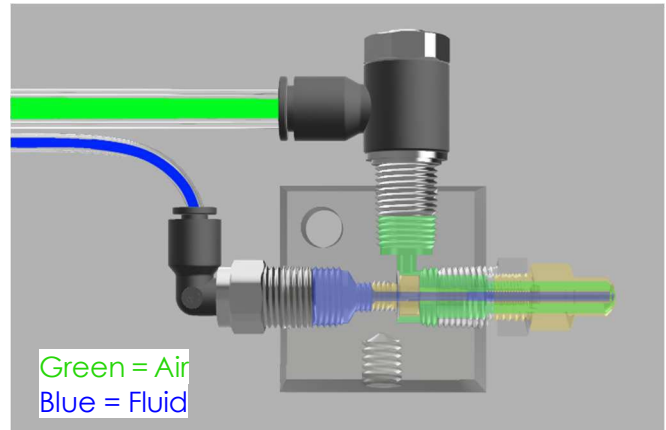

Cut-away view of Transition Block showing air and liquid mixing at the spray tip

A variety of single point spray assemblies are available to customize systems to meet your exacting needs. We offer more flexibility where there is limited access to the spray tool or workpiece.



Air/Liquid Spray Assembly Configurations for Single Spray Point

Multipoint B Manifolds are designed specifically for lubricating circular saws. These manifolds incorporate our Wet Tip mixing nozzle that can generate very high velocity for the liquid without mist or fog, thus impinging the wind current generated by the rotating saw. Spray angles ensure lubricant is applied to the cutting edge and the side of the blade.

Multipoint manifolds bring liquid and air together as shown.



B2 Manifold with Air Propelled Wet Tips

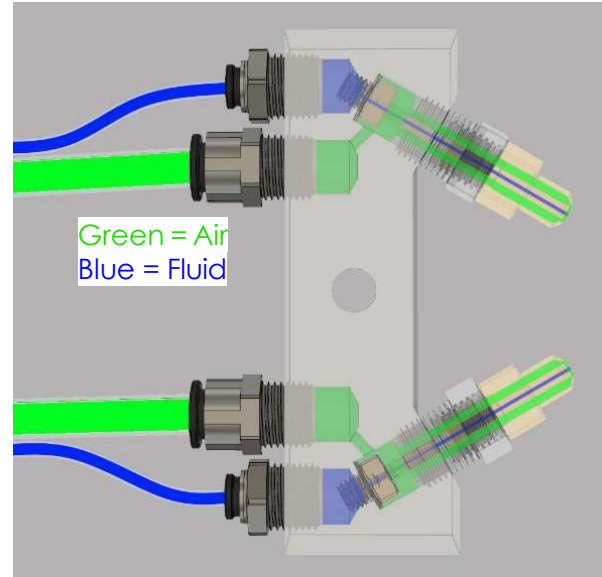

Cut-away view of B2 Manifold showing air and liquid mixing at the spray tip

Small manifolds with 2-spray points will suffice for saws up to 24" in diameter. Three block widths are available to accommodate space limitations.

The 3-spray point B3 manifold will provide enhanced lubrication for the cutting edge. The B3 manifold is recommended for saw blades that are larger than 24" diameter.

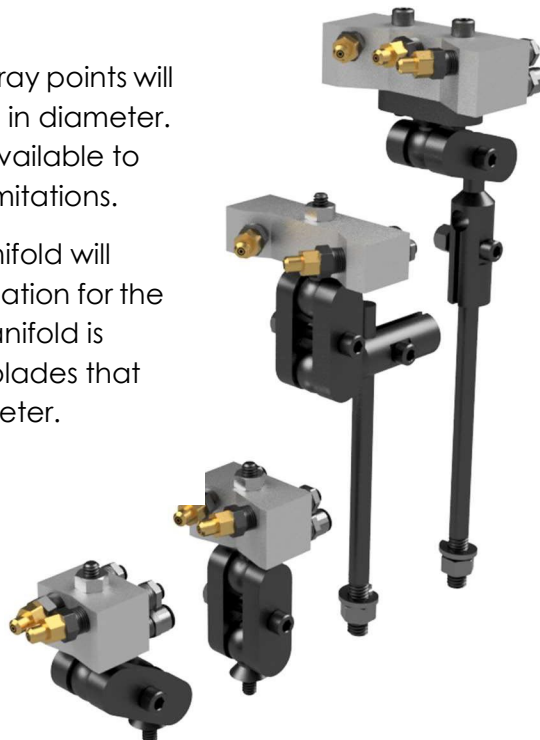

AMCOL offers a variety of mounting systems that allow for quick easy installation and maintenance of the spray manifolds onto your saw. These multifunctional mounting brackets can be adjusted to direct the spray to match the kerf angle of the saw.

How to Specify Your 6000E

Simple systems with up to 5 injectors operating in unison can be specified using a part number specification scheme that is designated as follows:

Systems with up to 4 injectors are housed in a 10H x 8W x 6D steel enclosure. 5 injector systems are fitted to a 16H x 10W x 6D size enclosure. There will be one ¼" NPT plant air connection that includes an in-line system pressure regulator with a coalescing filter.

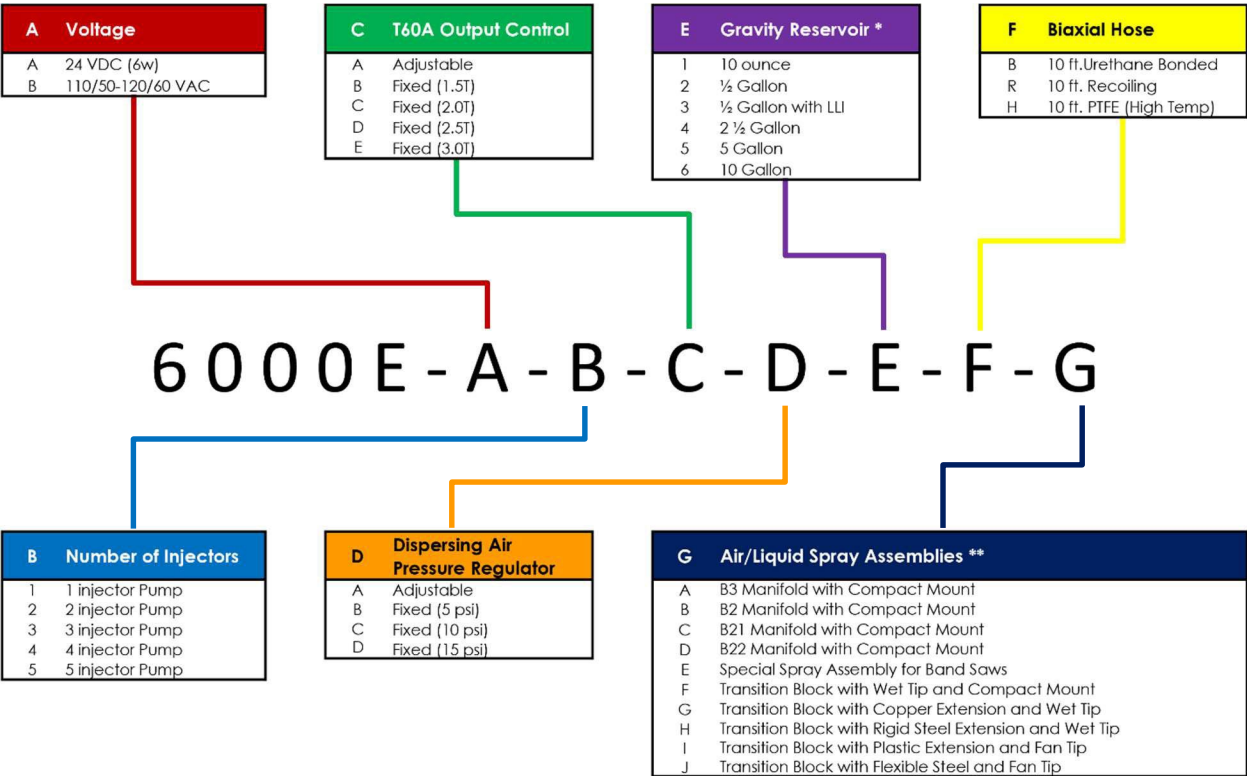

* Low level indicators for large capacity reservoirs purchased separately.

** Other options not shown are available.



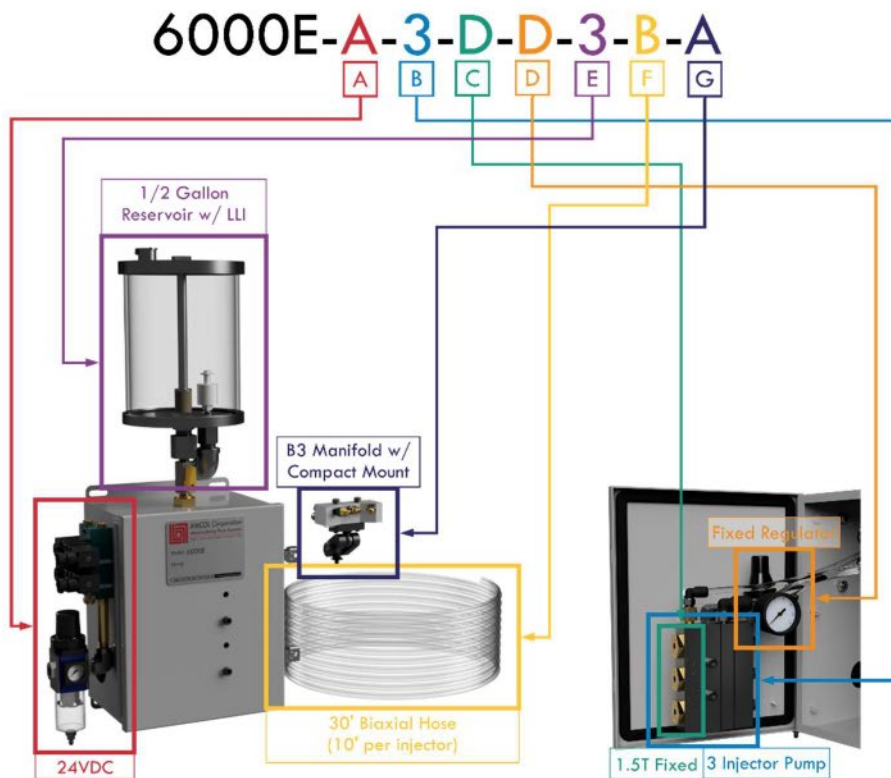
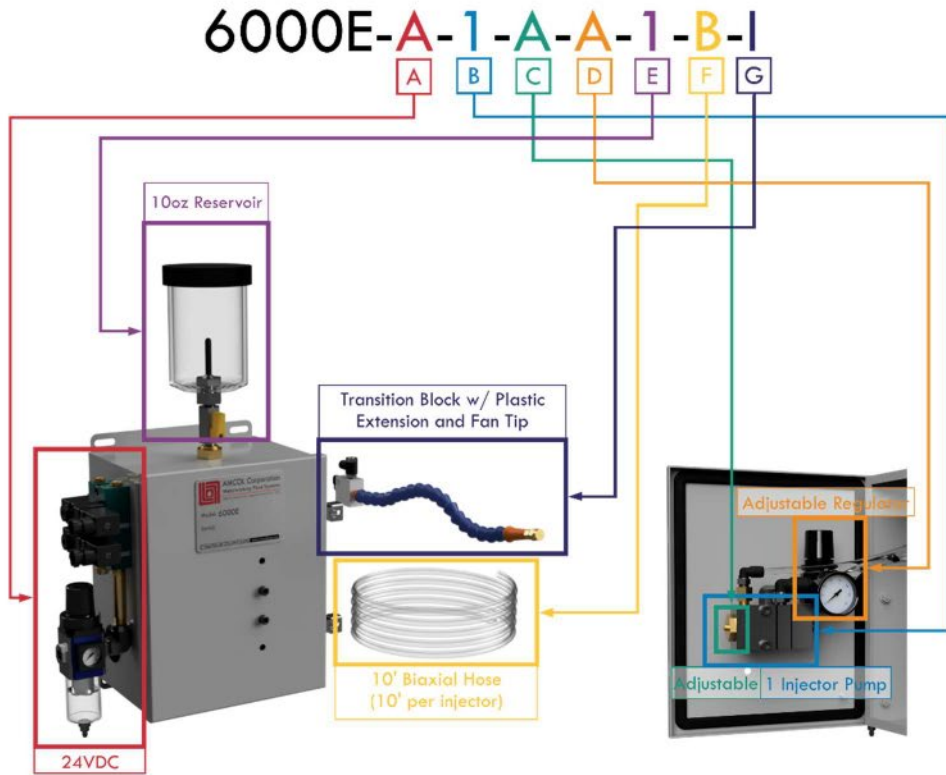

A zero (0) is used to indicate the exclusion of any given component.

Sample Systems



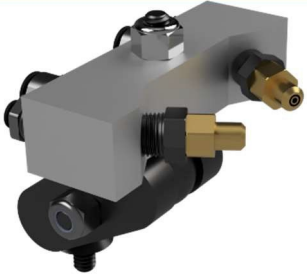



Air/Liquid Spray Assemblies

Multi-point Spray Assemblies for Saws

EPN #		Description
A		<p><u>B3 Manifold with Compact Mount</u> 3-point spray manifold designed specifically for large diameter circular saw blades (> 24").</p>
B		<p><u>B2 Manifold with Compact Mount</u> 2-point spray manifold designed specifically for small diameter circular saw blades (< 24").</p>
C		<p><u>B21 Manifold with Compact Mount</u> Spray manifold for small diameter circular saws with space limitations. Manifold is 1.75" wide.</p>
D		<p><u>B22 Manifold with Compact Mount</u> Spray manifold for small diameter circular saws with extremely limited space. Manifold is 1.375" wide.</p>
E		<p><u>Special Spray Assembly for Band Saws</u> Designed to completely coat both sides of the blade with little or no overspray. Open end is installed to allow for blade changing without moving spray assembly.</p>

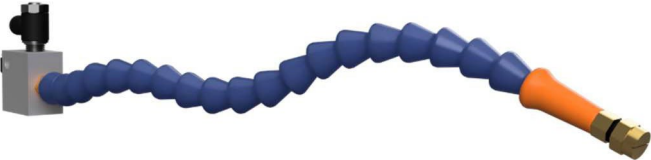
Single-point Transition Blocks

EPN #		Description
F		<p><u>Transition Block with Wet Tip and Compact Mount</u> Permanently mounted near the spray point with a highly directed spray.</p>
G		<p><u>Transition Block with Copper Extension and Wet Tip</u> Copper can be easily bent and shaped by hand to fit specific requirements, but is not meant to be continuously redirected.</p>
H		<p><u>Transition Block with Rigid Steel Extension and Wet Tip</u> Steel can only be bent with the appropriate tools and is meant for machine tool specific applications. Best for applications the tool spray point will not change. Extremely durable. Recommended where a straight extension or an extension with minimal bends is appropriate.</p>
I		<p><u>Transition Block with Plastic Extension and Fan Tip</u> Plastic can be bent and shaped to fit very specific angle requirements. Plastic is meant for applications where the spray assembly is regularly moved and redirected.</p>
J		<p><u>Transition Block with Flexible Steel and Fan Tip</u> Flexible steel conduit is most often supported at or near the spray point to insure repeatable spray direction.</p>

Addons

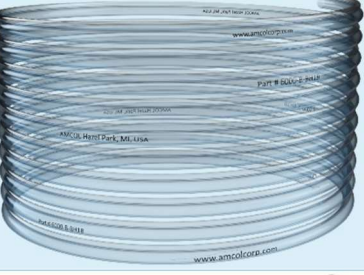
	Description	Part #
	Low level switch for 2.5- & 5-gallon reservoirs	LLI-622-5W
	Low level switch for 10-gallon reservoirs	LLI-622-10W
	Clear biaxial hose (black writing)	6000-B-BH1
	Clear biaxial hose (white writing)	6000-B-BH1A
	Blue biaxial hose (black writing)	6000-B-BH1B
	Blue biaxial hose (white writing)	6000-B-BH1C

Complex Systems with Multiple Posi-pumps

Complex multi-injector systems with multiple Posi-pumps are our specialty. These systems are typically fitted to automated work cells where individual sets of injectors are required to spray at different times. Two valves are included per Posi-pump. The number of injectors will determine the spray box size. Air/liquid mixing assemblies are most often unique individually tailored to your machine. A typical system configuration is shown.



6000-ETC Electronic Timing Controller

There are many situations where the electronic timing option for simple systems is desired, but the PLC outputs are not available. Often, there is only one output to control the spray cycle and no way to easily convert to electronic timing. AMCOL offers an independent timing controller that can convert your one output to two.

The 6000-ETC Controller is a self-contained PLC that is preprogrammed to interface with your machine to convert your one solenoid valve output to be a two-solenoid valve output.

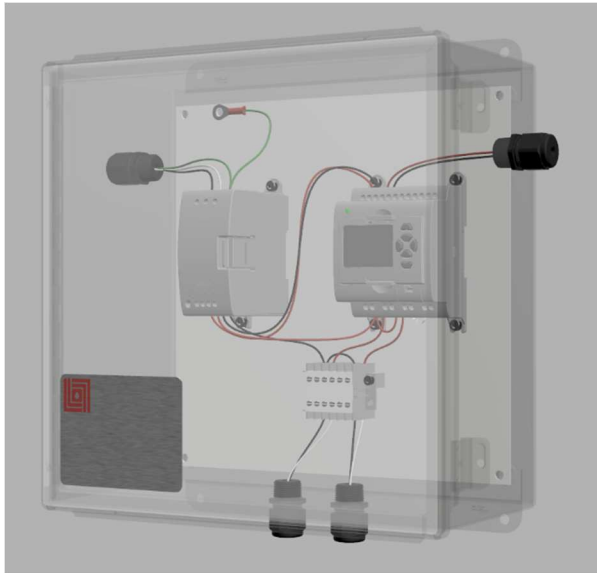

The 6000 ETC Controller is purchased separately and is available in two voltage configurations (24VDC Input and 110VAC Input). For more information about the 6000-ETC Controller, please see document: PS04.6000-ETC Controller.PB.

AMCOL CANMIST High Performance Lubricants

AMCOL offers a variety of CANMIST High Performance Lubricants to meet your specific needs. With your new electronically timed precision spray system, the properly matched fluid is critical. Only CANMIST fluids are recommended and fully compatible with 6000 Spray Systems.

**AMCOL recommends
CANMIST lubricants
for optimal performance.**



**Proven technology
refined over decades.**

Please see your AMCOL Technical Sales Representative to match the CANMIST Lubricant to your operation.

For installation, operation, maintenance, recommended settings, and troubleshooting, please see the 6000E Electronically Controlled Precision Lubrication System Operator's Manual.



AMCOL Corporation

21435 Dequindre, Hazel Park, MI 48030

248-414-5700

fax: 248-414-7489

www.amcolcorp.com