

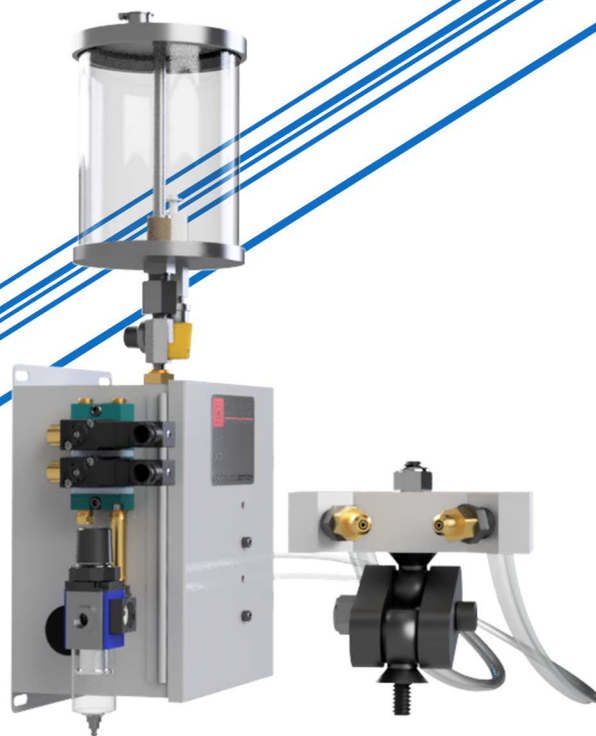

AMCOL CORPORATION
6000E ELECTRONICALLY
CONTROLLED PRECISION
LUBRICATION SYSTEM

Operator's Manual



Contents

| | |
|---|-------------------------------------|
| 1 Introduction | 2 |
| 2 Included Components..... | 3 |
| 3 Assembly and Installation | 4 |
| PRIOR TO GETTING STARTED | 4 |
| Installation | 4 |
| 4 Recommended Settings..... | Error! Bookmark not defined. |
| Settings with SMART Metering..... | Error! Bookmark not defined. |
| 5 Operation | 5 |
| 6 Priming/Re-priming the System | 8 |
| 7 System Troubleshooting | 8 |
| 8 T60A Posi-pump Troubleshooting..... | 9 |
| 9 Maintenance | 11 |
| Recommended Spares | 11 |
| Recommended Tools | 11 |
| Repair of the T60A Posi-Pump | 12 |
| T60A Posi-pump Bill of Materials | 13 |
| Preventative and Predictive Maintenance | 13 |
| Daily | 13 |
| Quarterly..... | 13 |
| Yearly | 13 |
| 10 Recommended Fluids | 14 |
| 11 Schematics and Drawings..... | 15 |



AMCOL Corporation

| | | | |
|---------------------------------------|--------------|-------------------|--|
| 21435 Dequindre, Hazel Park, MI 48030 | 248-414-5700 | fax: 248-414-7489 | www.amcolcorp.com |
|---------------------------------------|--------------|-------------------|--|

1 Introduction

The AMCOL 6000E Electronically Controlled Precision Lubrication Applicator is an air operated spray system used to accurately dispense minute quantities of liquid lubricants and coatings used in the production and fabrication of metal. With this system, fluids are injection metered from a gravity reservoir using patented positive displacement piston pumps and then mixed with air at the spray point. Multi-point lubrication is accomplished with multiple injectors or by splitting outputs at the spray point.

This operator's manual describes the installation, operation, and maintenance of your new AMCOL 6000E Precision Applicator. For more information on the system and the individual components, please refer to the preceding document: "AMCOL 6000E ELECTRONICALLY CONTROLLED PRECISION LUBRICATION SYSTEM - Technical Description."



2 Included Components

1. System Controls
2. Gravity Feed Reservoir
3. Air/Liquid Hose to Spray Point
4. Air/Liquid Spray Assembly

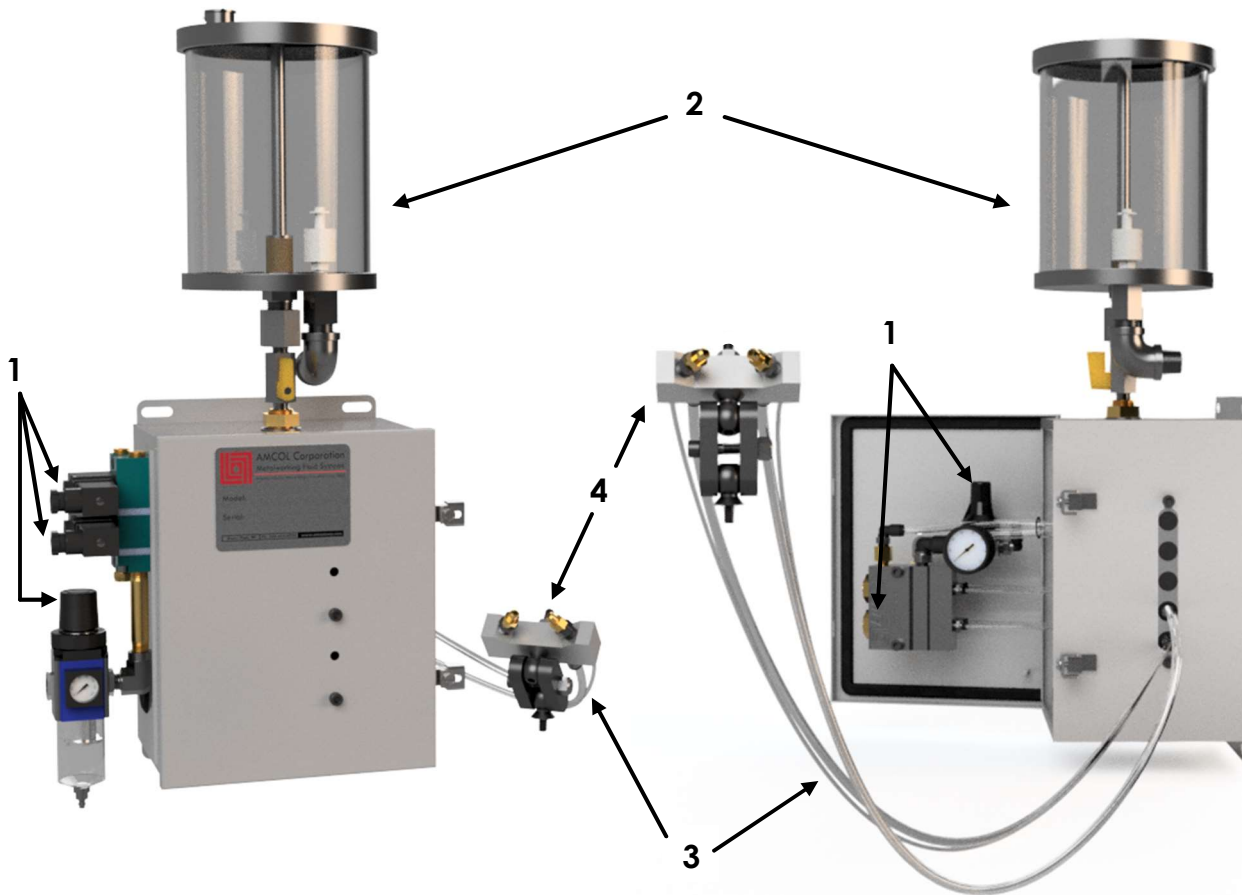

Shown is a 6000E Precision Applicator System with a two injector T60A Posi-pump, ½ Gallon Reservoir with Low Level Indicator, urethane bonded biaxial hose, and B2 Manifold with Air Propelled Wet Tips on a Compact Multifunctional Mounting Bracket.

For additional information about spray manifolds, nozzle extensions, spray tips, and mounting brackets, please see the AMCOL 6000 Series Spray Assemblies- Technical Description and Operator's Manual.

For additional information about simple electronic control for 6000E Series Applicators, see the AMCOL 6000-ETC Technical Description and Operator's Manual.

3 Assembly and Installation

PRIOR TO GETTING STARTED

- **WARNING! The AMCOL 6000E series applicator is serviced by a high-pressure air source. Pressurized air is inherently dangerous and only qualified individuals should be allowed to work on these systems.**
- **WARNING! Wear safety glasses at all times.**
- **WARNING! Lock out service air during assembly, disassembly, and related repairs.**
- **WARNING! Tighten all hose and fittings prior to operation.**
- **WARNING! Only use fluids that are compatible with aluminum, brass, steel, urethane, nylon, and acrylic.**

Installation

1. Review your applicator to see that no damage has occurred in shipment.
2. See that all your components and the related mounting is appropriate for your piece of equipment.
3. Ensure that your plant air source has the required capacity and is available, clean, and dry.
4. Mount the system controls in a protected area, which can be easily accessed by operations and maintenance personnel. Some components may require minor assembly as they have been shipped independently to avoid damage in transit.
5. Attach liquid reservoir to the system controls.
6. Mount transition blocks/manifold to the machine, while carefully observing that these items will not interfere with the activities associated with the use, maintenance and adjustment of your machine.
7. Spray tips should be mounted at the maximum distance from and directly at the spray target. This may require additional adjustments once the system is fully operational.
8. Connect system actuation to your machine controls; air pulse injection rate may also require an additional actuation source.
9. Connect plant air source and set the filter-regulator to 60 psi.
10. Fill the liquid reservoir and then open the shut-off valve on the bottom of the reservoir.
11. Manually actuate system, observing that system is leak free and all adjustments are operational. (The manual actuator is a push button over-ride recessed on top of the solenoid)
12. Under careful observation, operate system in production environment.

4 Recommended Settings

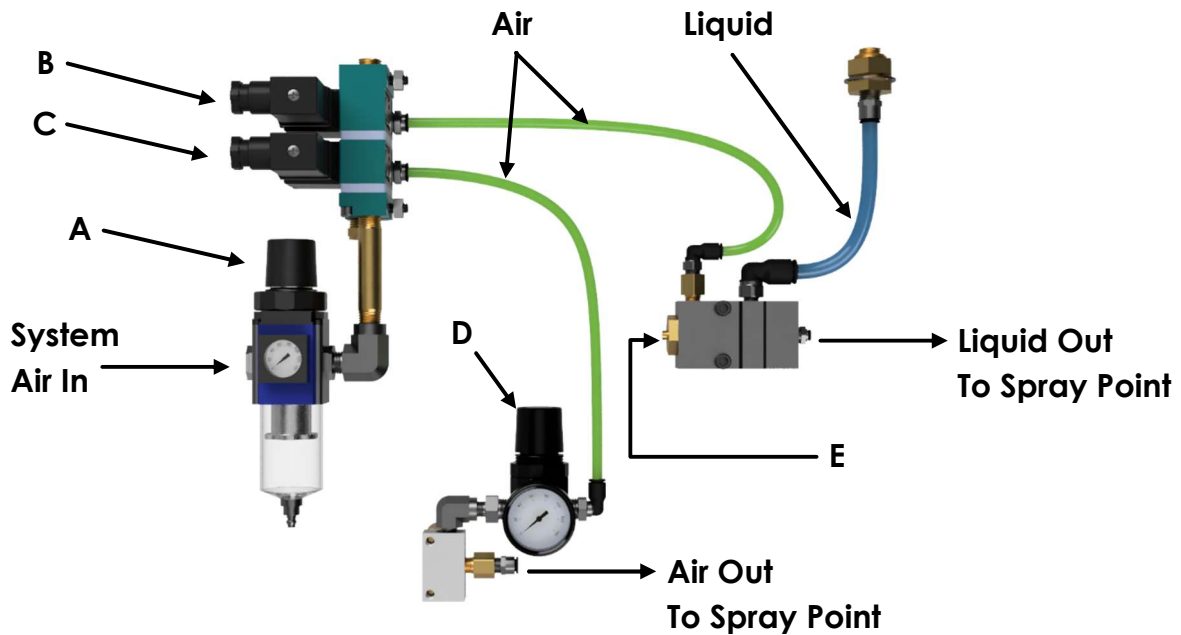

| Item ID | Description | Recommended Setting |
|---------|-------------------------------|--|
| A | System Air Pressure | 60 PSI |
| B | Injection Pulse Rate Solenoid | According to machine cycle rate and volume |
| C | Dispersing Air Solenoid | According to machine cycle rate |
| D | Dispersing Air Pressure | 10 PSI as a starting point. Adjustment of the flow control at the transition block is highly dependent on spray tip. Adjust as needed, DO NOT mist or fog! (for fixed air pressure see below) |
| E | Injection Volume | Start at 1.5 turns open from off (for fixed injection volume see below) |

Settings with SMART Metering

All 6000E systems include a dual solenoid control package that eliminates the variability of traditional pneumatic controls. Fixed position hex caps and non-adjustable regulators remove variability associated with spray volume and pattern.

- ① Fixed hex caps use set screws and epoxy to lock the distance of the adjustment screw inside the hex cap. This allows for a consistent, minimal fluid output to remove variability in spray volume. (setting engraved on hex cap)
- ② Nonadjustable regulators remove the variability in adjustable regulators, allowing for a consistent spray pattern at the spray point. (setting marked on bottom of regulator)



Using a combination of SMART Metering components, all variability of a 6000E system can be removed, allowing the spray volume to be solely based on injection rate of the T60A pump.

5 Operation

Before Getting Started

- Ensure all hoses are connected to the appropriate fittings and are tightly secured.
- Ensure all wiring connections to the solenoids are secure.
- Refill reservoir if low or empty.
- Securely connect an air source to the system air regulator. Check system pressure (60 psi recommended).
- Re-prime the system if liquid is not at the spray point.

Operating the Dispersing Air Solenoid

- Observe 0 psi on the Dispersing Air Regulator when closed.
- Manually open the solenoid and set the Dispersing Air Pressure.

Operating the Injection Pulse Rate Solenoid

- Observe no fluid output when the Pulse Rate Solenoid is closed.
- Manually actuate the solenoid and observe the fluid output. Modify injection volume settings accordingly (clockwise to decrease, counterclockwise to increase).

Setting Injection Pulse Rate

- The Injection Pulse Rate Solenoid is programmed and controlled with your PLC.
- T60A Posi-pumps can be cycled up to 10 times per second using the following timing:
 - Injection Pulse Rate Solenoid open for 20ms
 - Injection Pulse Rate Solenoid closed for 80ms
- If using a 6000-ETC, simply press the up or down buttons on the PLC to modify Injection Rate without any changes to programming. See the AMCOL 6000 ETC Technical Description and Operator's Manual for more information.

Proper Operation

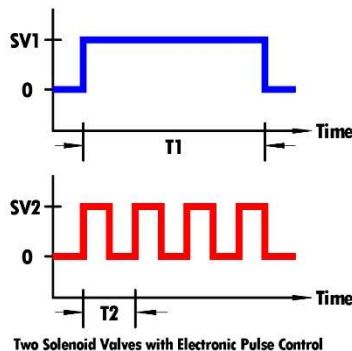

System Timing

Correct system timing can be seen to the left. SV1 is the Dispersing Air Solenoid and should be kept on during for the full duration of the spray cycle (T_1). SV2 is the Injection Pulse Rate Solenoid, which should be actuated according to the desired cycle rate (T_2), up to 10 times per second.

Manual Actuation

To manually test the system to observe spray output, perform the following:

- Activate the Dispersing Air Solenoid. This solenoid should remain open while testing spray volume and pattern. If this solenoid is not activated, liquid will only drip out of the spray tips instead of being forced out with air.
- Pulse the Injection Pulse Rate Solenoid at a regular rate. Each actuation corresponds to 1 injection cycle.

To manually activate the solenoid, press the manual override button here:



Manual operation should be used to verify current settings, test spray coating, and troubleshoot.



Automatic Actuation

To automatically use the 6000E system, it should be interfaced with the control PLC, which should contain the following sequence:

- Activate the Dispersing Air Solenoid whenever the 6000E is operating.
- Pulse the Injection Pulse Rate Solenoid at the desired rate.
- Ensure the settings do not exceed the minimum 20ms “on” or 80ms “off” times, or the T60A pump will not operate.

While running automatically, the spray volume and pattern should be consistent. No misting or fogging should be present. See Section 7 for troubleshooting.

6 Priming/Re-priming the System

1. Fill the reservoir.
2. Open the ball valve on the bottom of the reservoir.
3. Open pumps by turning the T60A liquid adjustment screw counterclockwise.
4. Repeatedly cycle the injectors.
5. Once liquid reaches the spray point, readjust the T60A Posi-pump to the desired setting.
6. Adjust spray air pressure if necessary.

7 System Troubleshooting

Check in order as listed

Fluid Volume Inappropriate

- Injectors misadjusted: adjust individual injectors.
- Incorrect cycle timing: readjust Injection Pulse Rate Solenoid.

Inconsistent Spray Volume to One Spray Point

- Spray tip is clogged: simply remove, clean, and replace spray tip.
- Spray tip is not properly attached: be sure spray tip is tightly threaded and secured, and that the 1/8" liquid line is properly installed onto barbed connectors.
- Spray tip is damaged: remove and replace.
- Liquid or air hose is severed or incorrectly attached: reconnect or replace.
- T60A Posi-pump needs to be rebuilt: see instructions on page 12.

Inconsistent Spray Volume to All Spray Points

- Be sure the fluid reservoir ball valve is open.
- Fluid level is low: refill reservoir.
- Strainer on reservoir is clogged: clean or replace.

Mist or Fog

- Manifolded dispensing air pressure set too high: adjust.
- Individual spray point flow set too high: adjust.

Liquid from Back of Injector

- Injector contact seals leaking: clean injector and replace O-ring.

No or Low Dispersing Air

- Manifoldded dispersing air pressure set too low: adjust.
- Air hose is kinked or cut: repair or replace.
- Spray tip is clogged: clean or replace.
- Spray tip is damaged: replace.

Air in Liquid Line

- Fluid line is not properly attached to pump: replace hose or fitting.
- Injector seal is failing: rebuild or replace.

Liquid Drains from Spray Tip

- Injector check valve is failing: rebuild or replace.
- Liquid line in single point nozzle assembly is damaged or disconnected: replace

8 T60A Posi-pump Troubleshooting

No Liquid

- Pump is turned off: turn liquid adjustment screw counterclockwise.
- Pump is seized: remove, clean, and rebuild.
- Reservoir is empty: fill.
- Air pressure is too low: adjust to over 60 PSI.

Bubbles from Injectors

- Air seals are leaking: replace.
- Exit fitting is leaking: replace.

Liquid Drains from Injector Outlet

- Exit fitting is leaking: replace.
- Evacuation valve is ineffective: clean or replace.
- Biaxial hose is trimmed incorrectly: be sure hose is cut straight with no burrs or deformities.

Too Much Liquid

- T60A adjustment screw is too far open: adjust clockwise.

Not Enough Liquid

- Too far closed: adjust counterclockwise
- Liquid outlet (or hose) is kinked: replace.

Liquid Volume is Inconsistent

- Injector is contaminated: clean.
- O-ring seal is faulty: replace or rebuild.

Liquid Volume is Increasing with Time



- O-ring on adjustment stem is deteriorated: replace.

Liquid Leaking from Pump Body

- O-ring seals are worn: replace.
- Piston sleeve is not tight: tighten.
- Piston sleeve is worn: rebuild complete injector

9 Maintenance



Recommended Spares

| | Description | Part Number | Quantity |
|---|---------------------------------------|-------------|------------------|
|  | Biaxial hose | 6000-B-BH1 | 10' per injector |
|  | Repair Kit for T60A | T60A-RK | 1 per injector |
|  | T60A Assembly with Fittings for 6000E | T60A-#-E * | 1 |

Spray assemblies are unique to each 6000 and should be replaced accordingly when damaged. See the 6000 Series Spray Assemblies Technical Description for information about the various parts and options.

* Number of injectors on replacement pump must match current system

Recommended Tools

| | Description | Part Number | Quantity |
|---|--------------------|-------------|----------|
|  | O-ring repair tool | ORT-T60 | 1 |
|  | T-60A repair tool | RT-T60 | 1 |

Repair of the T60A Posi-Pump



1. Remove brass hex cap from the body using a 7/8" wrench.
2. Unscrew adjustment stem from brass hex cap using standard screwdriver.
3. Thread RT-T60A Repair Tool into threaded hole on top of piston subassembly. Slowly pull piston assemble straight out of piston sleeve.
4. Remove Helical Spring from Piston Sleeve.
5. Unscrew Piston Sleeve from pump body using the ears on the RT-T60A Repair Tool and remove.
6. Clean and observe all components, both internally and externally.
7. Using the liquid to be pumped as a lubricant, replace and install all associated components in reverse order.

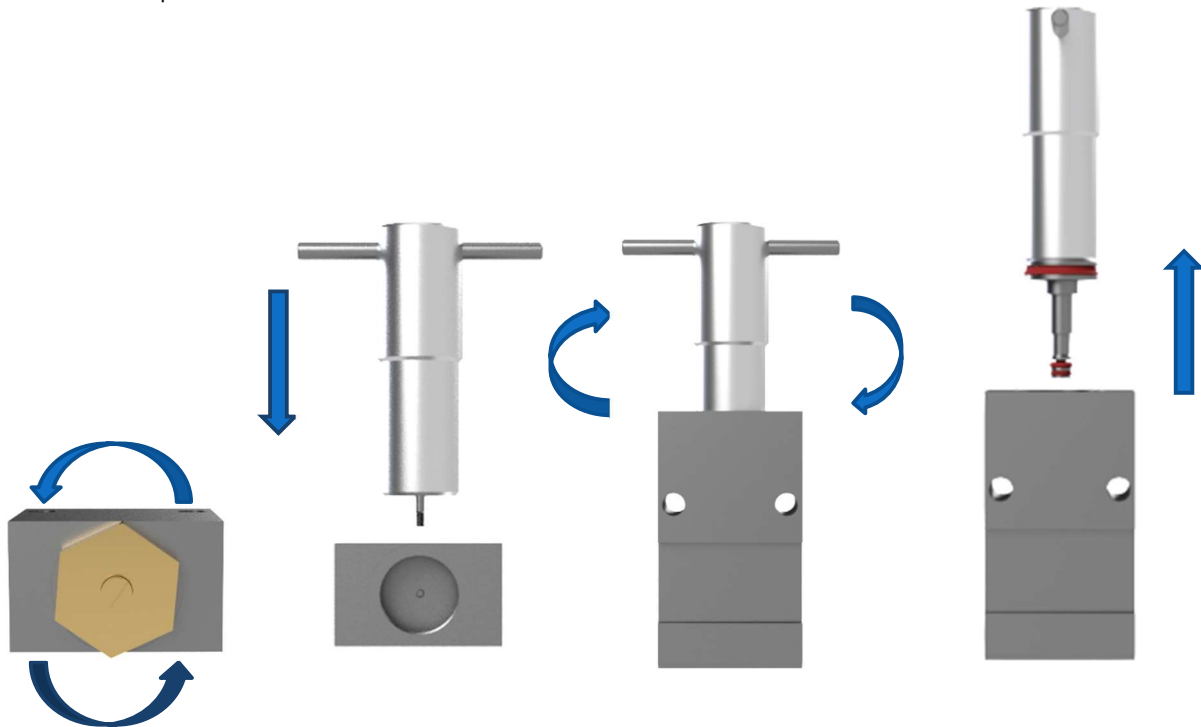

T60A Posi-pump Bill of Materials

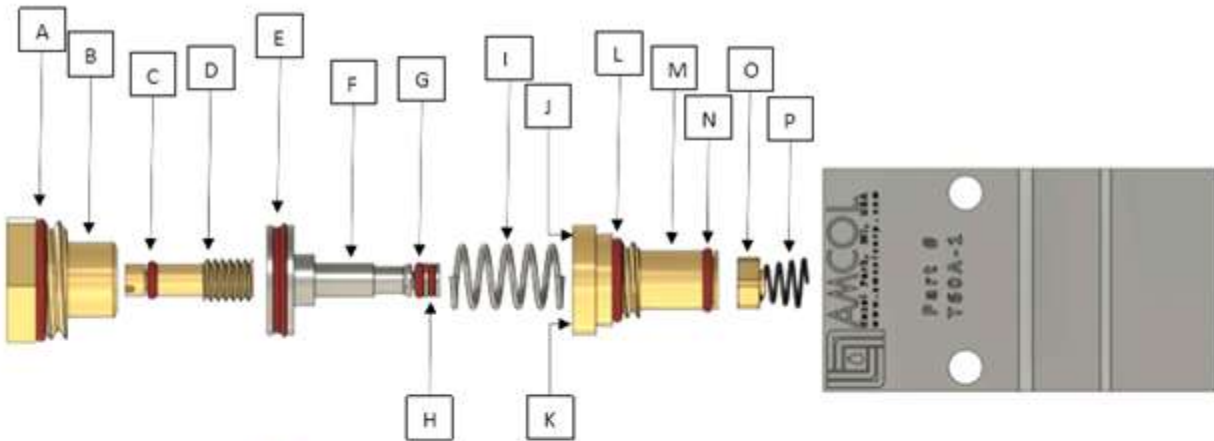

| Ref # | Description | Part Number |
|-------|---|-------------|
| A | Viton-A O-Ring for Brass Cap | A-3395-13 |
| B | Brass hex cap | B-2799-6 |
| C | Viton-A O-Ring | A-3395-1 |
| D | Liquid Adjustment stem | B-2799-7 |
| E | Viton U-Cup Seal | A-5074-17 |
| F | Piston Sub-assembly | YA-7167-1 |
| G | Slip O-ring | A-4213-39 |
| H | Bottom Piston O-ring | A-4213-37 |
| I | Helical spring | A-7130-1 |
| J | Inner O-ring | A-3395-5 |
| K | O-ring Retaining Ring | YA-7168-1 |
| L | Viton-A O-Ring For Piston Sleeve (top) | A-3395-9 |
| M | Piston sleeve | YB-3543-1 |
| N | Viton-A O-Ring For Piston Sleeve (bottom) | A-3395-6 |
| O | Viton Evacuation valve | A-5087-2 |
| P | Conical spring | A-4957-17 |

Preventative and Predictive Maintenance

Daily

- Observe fluid level and fill as necessary
- Observe system settings
- Observe system for damage

Quarterly

- Empty, clean, and refill reservoir
- Replace liquid and air hose

Yearly

- Rebuild or replace T60A Posi-pumps

10 Recommended Fluids

AMCOL offers a variety of CANMIST High Performance Lubricants to meet your specific needs. With your new 6000E Electronically Controlled Precision Lubrication System, the properly matched fluid is of critical importance. Only CANMIST fluids are recommended and fully compatible with 6000 Spray Systems. Contact an AMCOL representative to select the right CANMIST fluid for your operation.

**AMCOL recommends
CANMIST lubricants
for optimal performance.**



**Proven technology
refined over decades.**

11 Schematics and Drawings

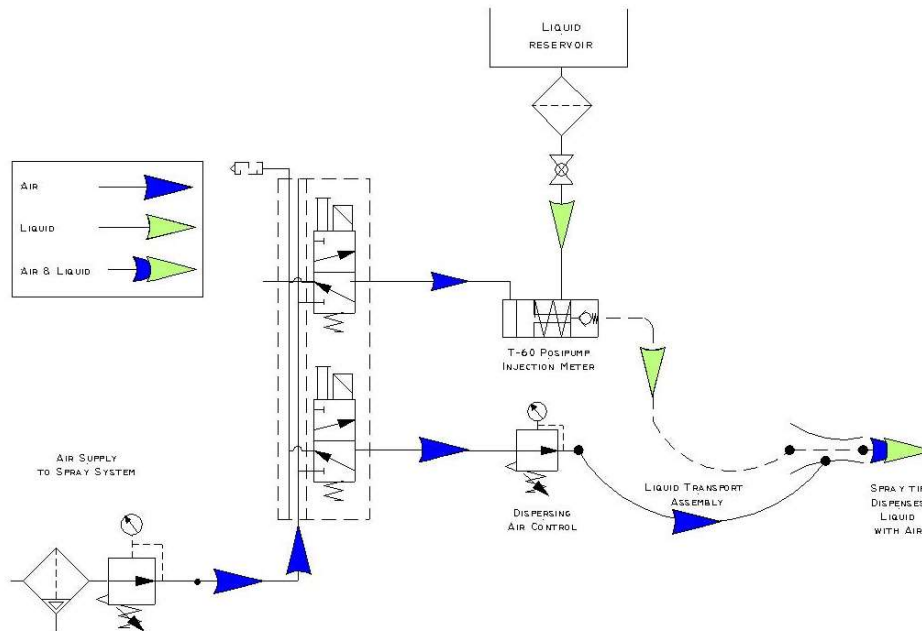

General schematic for dual air source

6000E-24-3-D-D-3-B-A

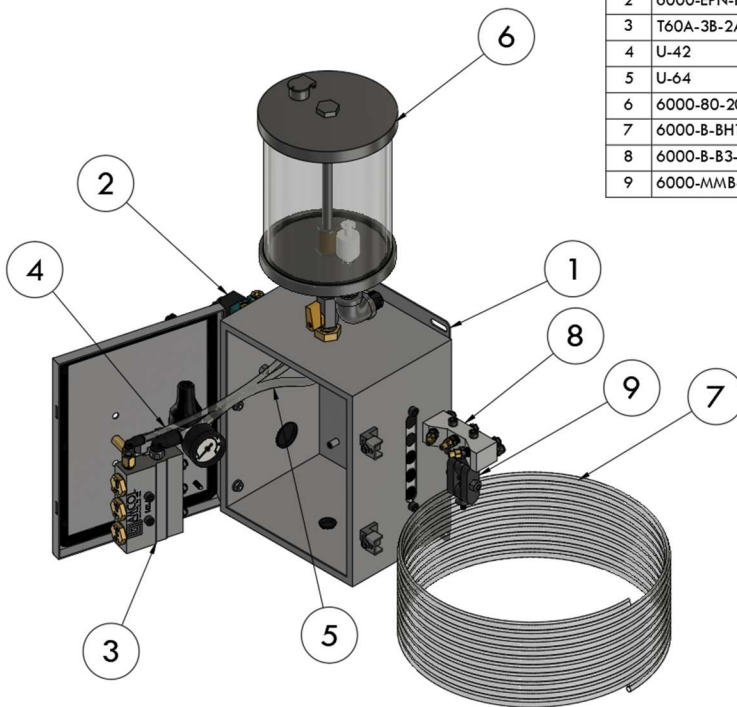

| PARTS LIST | | |
|------------|------------------------|---|
| ITEM | PART NUMBER | DESCRIPTION |
| 1 | 6030-100-T60C-AC3-SM | Enclosure for 6000 Series |
| 2 | 6000-EPN-KS2(24VDC) | Air Valve with 2 Strip Mount Solenoid |
| 3 | T60A-3B-2AX-NAR15-1.5T | Biaxial T60A-3, 1.5T Hex Cap, 15psi Regulator |
| 4 | U-42 | $\frac{1}{4}$ Urethane Tubing |
| 5 | U-64 | $\frac{3}{8}$ Urethane Tubing |
| 6 | 6000-80-20-20 | $\frac{1}{2}$ Gallon Reservoir with Low Level Indicator |
| 7 | 6000-B-BH1 | Biaxial Hose |
| 8 | 6000-B-B3-1022WT1 | B3 Manifold with Air Propelled Wet Tips |
| 9 | 6000-MMB-C3 | Multifunctional Mounting Bracket for B3 Manifold |

Sample System with Components (6000E-24-3-D-D-3-B-A)

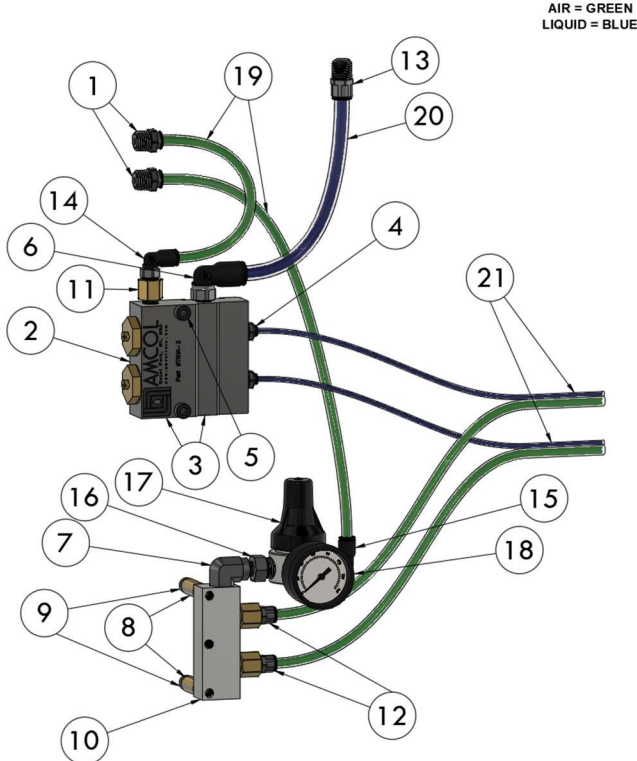

AIR = GREEN
LIQUID = BLUE

| PARTS LIST | | | |
|------------|-----|-------------|---|
| ITEM | QTY | PART NUMBER | DESCRIPTION |
| 1 | 2 | 3175 56 14 | 1/4" TUBE X 1/4" MALE THREAD CONNECTOR |
| 2 | 1 | T60A-2 | T60 POSI-PUMP, 2 INJECTOR |
| 3 | 2 | 12004 | 1/8"-27 PTF FLUSH PLUG - BLACK |
| 4 | 2 | 3175 53 11 | 1/8" TUBE 1/8" NPT CONNECTOR |
| 5 | 2 | 25C125SHC | 1/4"-20 X 1 1/4" SCS |
| 6 | 1 | 3109 60 11 | PUSHLOCK ELBOW 3/8" TUBE X 1/8" MALE THREAD |
| 7 | 1 | 2-PC-18 | 1/8" MALE X 1/8" FEMALE DEG. STEEL ELBOW |
| 8 | 2 | 6000-60-020 | STACKING NUT |
| 9 | 2 | 25C37SHC | 1/4"-20 X 3/8" SCS |
| 10 | 1 | 2-AM-2 | 2 HOSE BIAXIAL BLOCK MANIFOLD |
| 11 | 3 | 222P-2-2 | 1/8" - 1/8" PIPE ADAPTER |
| 12 | 2 | 3175 56 11 | 1/4" TUBE X 1/8" MALE THREAD CONNECTOR |
| 13 | 1 | 3175 60 14 | 3/8" TUBE X 1/4" MALE THREAD CONNECTOR |
| 14 | 1 | 3109 56 11 | PUSHLOCK ELBOW 1/4" TUBE X 1/8" MALE THREAD |
| 15 | 1 | 3109 56 14 | Pushlock Elbow 1/4" Tube x 1/4" Male Thread |
| 16 | 1 | 4-2-PC-11 | 1/4" M x 1/8" M Reducer Nipple |
| 17 | 1 | 1777K2-AC15 | 1/4" Regulator 1.5psi- Non Adjustable |
| 18 | 1 | 18-013-212 | 140 PSI PRESSURE GAUGE, 1/8" BACK MOUNT |
| 19 | 1 | U-42 | 1/2 Urethane Tubing |
| 20 | 1 | U-64 | 3/8 Urethane Tubing |
| 21 | 1 | 6000-B-BH1 | Biaxial Hose |

T60A-2B-1AX-NAR15 Complete Assembly

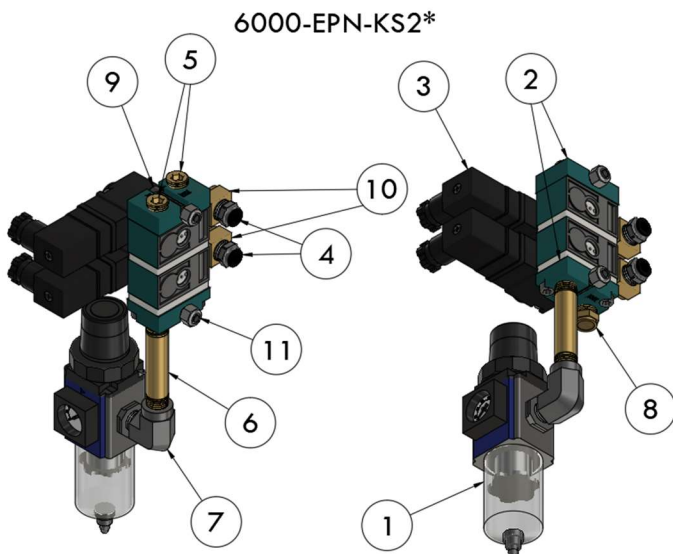

6000-EPN-KS2*

| PARTS LIST | | | |
|------------|-----|--------------|--|
| ITEM | QTY | PART NUMBER | DESCRIPTION |
| 1 | 1 | 807-202-M1KA | 3/4" Filter-Regulator |
| 2 | 1 | M-01001-01 | End Plate Kit For Strip Mount |
| 3 | 2 | 183B-112JB | Strip Mt Valve w/ Sol. (110V) * |
| 4 | 2 | 3175 56 14 | 3/4" Tube x 1/4" Male Thread Connector |
| 5 | 2 | 219P-4 | 3/4" Countersunk Plug |
| 6 | 1 | 215PNL-4-30 | 3/8" x 1 1/2" Nipple |
| 7 | 1 | 4-PC-18 | 90 Deg Elbow-3/4" M/M Pipe |
| 8 | 1 | ASP-2-BV | Short Muffler |
| 9 | 2 | 25C125SHC | 3/4"-20 x 1 1/4" Socket Cap SCS |
| 10 | 2 | 2202P-4-4 | 3/4" M x 1/4" F Brass Street Elbow |
| 11 | 2 | 25CNNEZ | 1/2" x 20 Nylon Insert Lock Nut |

* Other Voltages available, contact your sales representative for information

System Actuation Assembly

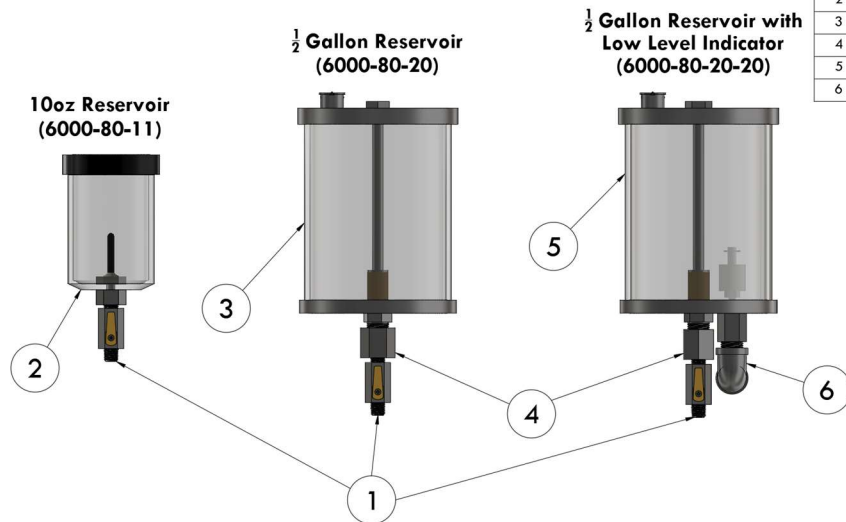

| PARTS LIST | | |
|------------|--------------|--------------------------------|
| ITEM | PART NUMBER | DESCRIPTION |
| 1 | MV608-4 | 1/4" M X 1/4" F BALL VALVE |
| 2 | A-5409-1 | 10 Ounce Reservoir with Filter |
| 3 | B-966-16-S01 | 1/2 Gallon Reservoir |
| 4 | O201-8-4 | 1/2 F x 1/4 M P/H Hose Adapter |
| 5 | YB-5167-7 | 1/2 Gallon Reservoir with LLI |
| 6 | ELM90-50 | 1/2" Male Iron 90 Deg Elbow |

Top Mounted Reservoir Assemblies

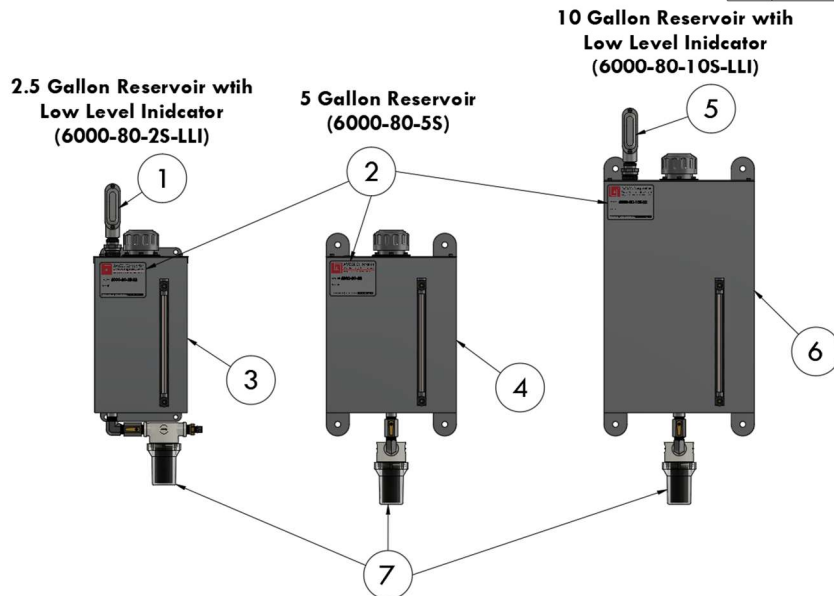

| PARTS LIST | | |
|------------|--------------|--|
| ITEM | PART NUMBER | DESCRIPTION |
| 1 | LLI-622-5W | Low Level Indicator for 2.5 and 5 Gallon Reservoir |
| 2 | 2-SEP | SERIALIZED EQUIPMENT PLATE |
| 3 | 80-2.5-20-SA | 2.5 Gallon Gravity Feed Reservoir Stock Assembly |
| 4 | 80-5-20-SA | 5 Gallon Gravity Feed Reservoir Stock Assembly |
| 5 | LLI-622-10W | Low Level Indicator for 10 Gallon Reservoir |
| 6 | 80-10-20-SA | 10 Gallon Gravity Feed Reservoir Stock Assembly |
| 7 | 6000-LFA | Liquid Feed Assembly |

Wall Mounted Reservoir Assemblies

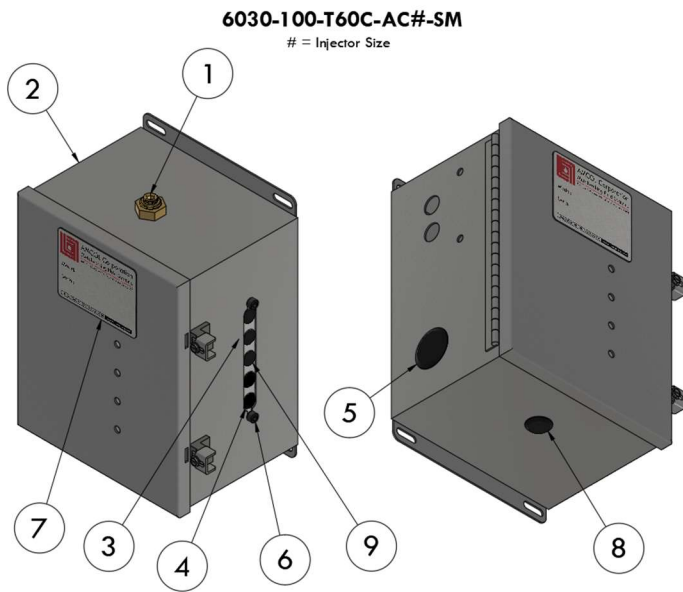

| PARTS LIST | | |
|------------|---------------|-------------------------------------|
| ITEM | PART NUMBER | DESCRIPTION |
| 1 | T6030-LI-BH | Liquid-In Bulkhead |
| 2 | 6030-100-T60C | Enclosure for 6030 |
| 3 | 6000-AEP | Aluminum Plate |
| 4 | 9600K33 | Rubber Grommet* |
| 5 | 9750K55 | Black Polyethylene Plug- 1 1/4" |
| 6 | 6000-055-60 | 1/2"-20 x 1/2" Socket Cap SCS |
| 7 | 2-SEP | Serialized Equipment Plate |
| 8 | 9750K53 | Polyethylene Snap-in Finishing Plug |
| 9 | 9688K132 | Black Nylon Finishing Plug 7/8" |

* Number of Rubber Grommets and Black Nylon Plugs are different based on injector size

6000E Enclosure Assembly (2 Injector Shown)

AMCOL
Corporation



6000E Support



AMCOL Corporation

| | | | |
|---------------------------------------|--------------|-------------------|--|
| 21435 Dequindre, Hazel Park, MI 48030 | 248-414-5700 | fax: 248-414-7489 | www.amcolcorp.com |
|---------------------------------------|--------------|-------------------|--|