

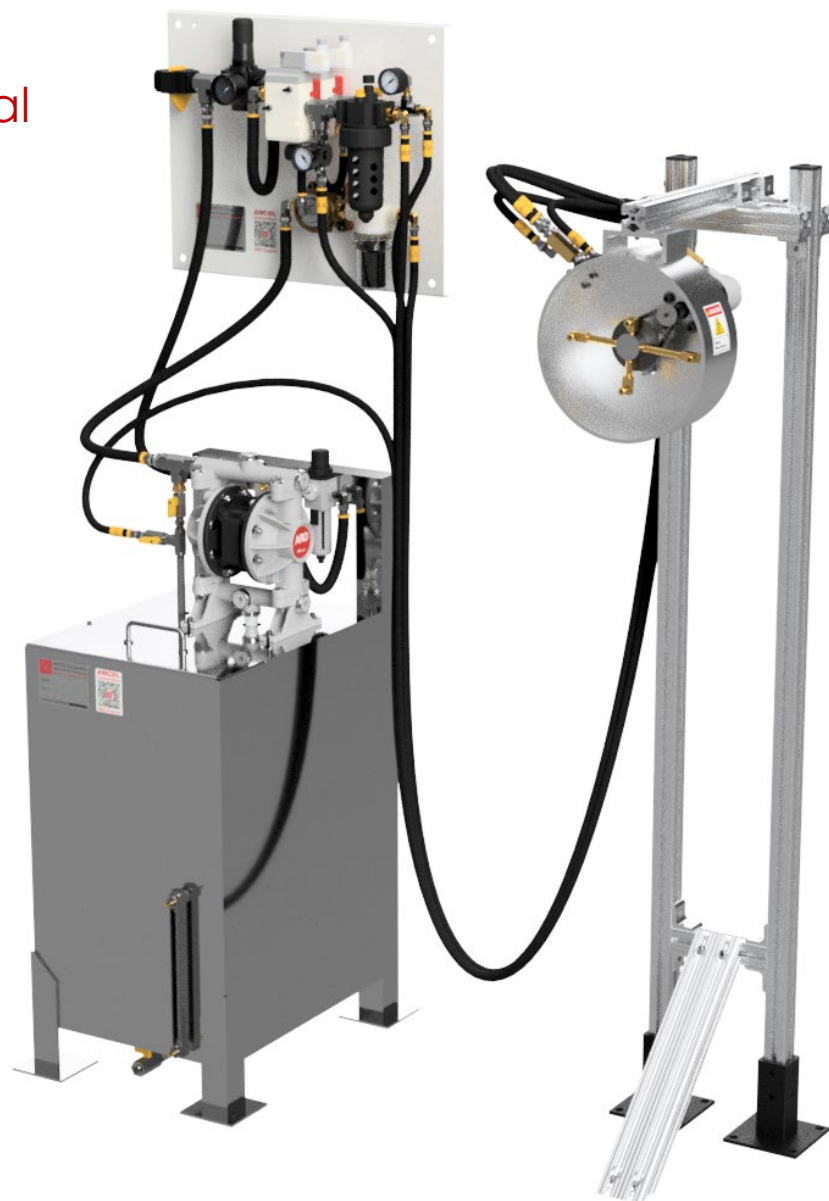

AMCOL CORPORATION
**3063 BILLET SPRAY
SYSTEMS**

Operator's Manual

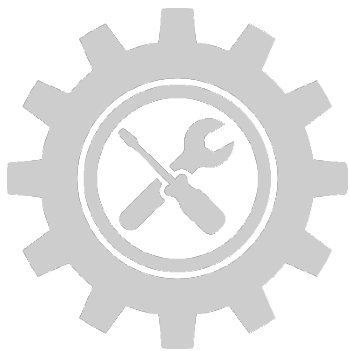

Contents

1 Introduction	2
2 Included Components.....	3
3 Installation.....	4
<i>PRIOR TO GETTING STARTED</i>	4
Installation	4
4 Operation	6
System Operating Cycle.....	6
034 Atomizer	7
Liquid Air Purge.....	8
5 Recommended Settings.....	9
6 Maintenance	10
Recommended Spares.....	10
Preventative and Predictive Maintenance	13
Daily	13
Quarterly.....	13
Yearly	13
7 System Troubleshooting	14
<i>No Liquid</i>	14
<i>Too Much Liquid</i>	15
<i>Too Little Liquid or Poor Coating</i>	15
<i>Fluid Runs on or Is Not Atomized During Part or All of the Spray Cycle</i>	15
PA201 Refractometer	16
8 System Schematics.....	17
9 Drawings	18



AMCOL Corporation

21435 Dequindre, Hazel Park, MI 48030	248-414-5700	fax: 248-414-7489	www.amcolcorp.com
---------------------------------------	--------------	-------------------	--

1 Introduction

This manual features instructions regarding the installation, operation, and maintenance of the AMCOL model 3063 Billet Spray Systems. For more information on the system and its components, please refer to the AMCOL model 3063 Billet Spray Systems Technical Description.



2 Included Components

Standard components included with every standard 3063 system:

1. Valve package with two 3-way Solenoids for PLC interface.
2. Liquid reservoir with liquid air purge and recirculation capability.
3. Rotating spray head with overspray cover.
4. Fixed position mounting assembly.
5. Fire resistant hose assemblies.

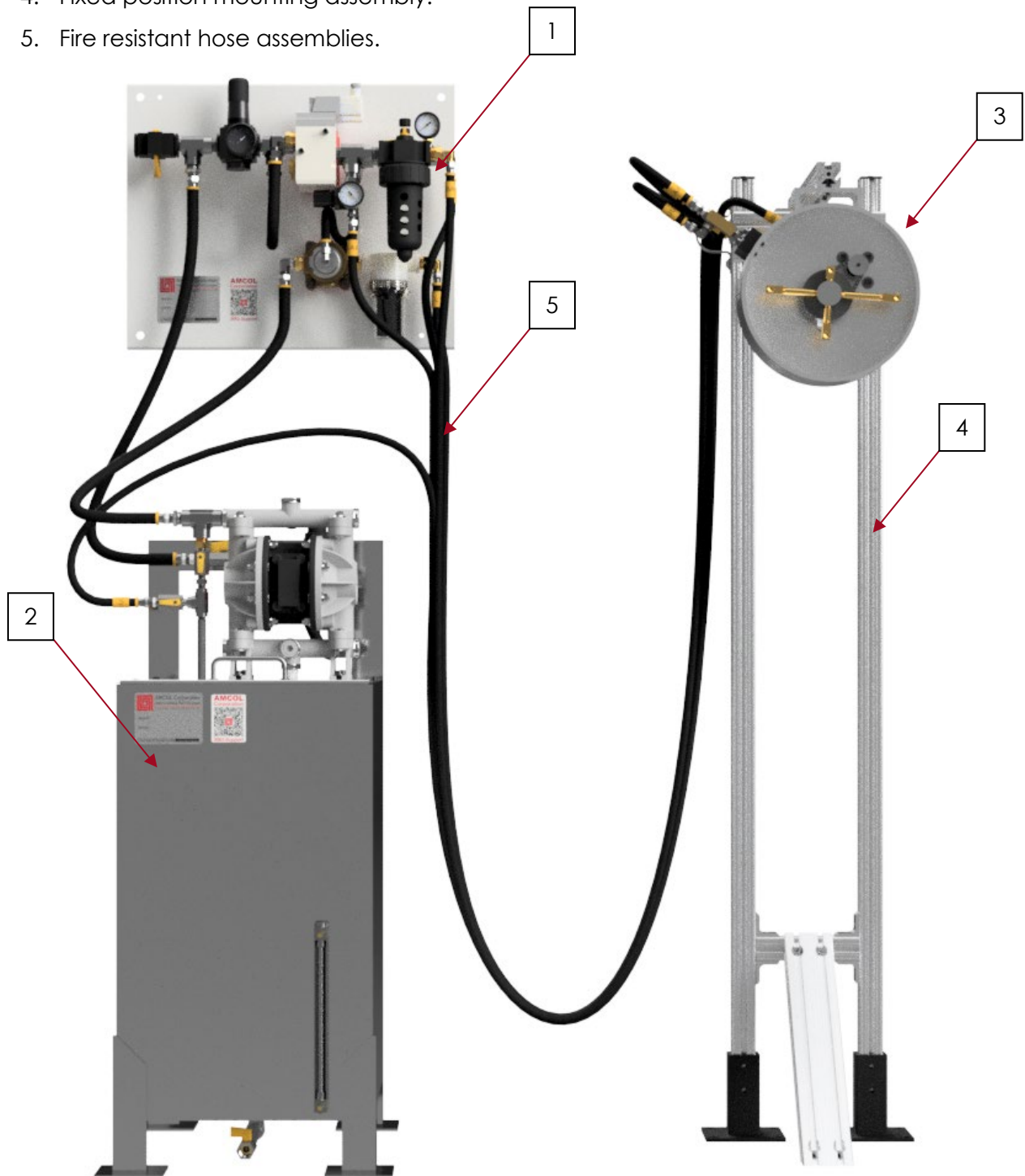

3 Installation

PRIOR TO GETTING STARTED

• **WARNING! DO NOT DISASSEMBLE, REPAIR, OR REPLACE COMPONENTS OR SUBASSEMBLIES OF THIS SYSTEM WITHOUT FIRST DEENERGIZING THE SYSTEM AIR SOURCE WITH LOCK AND TAG; THIS CAN BE TESTED BY VISUALLY INSPECTING THE PRIMARY AIR GAUGE (A) ON THE VALVE PACKAGE TO BE AT 0 PSI AND MANUALLY ATTEMPTING TO ACTUATE EITHER THREE-WAY AIR VALVE ON THE VALVE PACKAGE.**

• **WARNING! BE SURE THAT THE PRESS IS PROPERLY GUARDED IN ORDER TO AVOID INADVERTENT OR UNINTENDED ACCESS TO THE SPRAY HEAD BY UNTRAINED PERSONNEL. REFERENCE ANSI B11.17 OR SIMILAR PRESS GUARDING STANDARD.**

• **WARNING! BE SURE TO MOUNT THE RESERVOIR AND VALVE PACKAGE OUTSIDE OF THE GUARDED AREA, AS THEY WILL HAVE TO BE ACCESSED DURING NORMAL PRESS OPERATION.**

• **WARNING! DO NOT ATTEMPT TO ADJUST OR MODIFY NOZZLES, WHICH WILL BE WITHIN THE GUARDED AREA, WITHOUT DEENERGIZING THE PRESS WITH LOCK AND TAG.**

• **WARNING! THE SYSTEM IS NOT DESIGNED OR CAPABLE OF DISPENSING FLAMMABLE OR COMBUSTIBLE LIQUIDS.**

• **WARNING! USE PROPER EYE PROTECTION WITH SIDE SHIELDS WHEN IN THE AREA OF OPERATION. DURING TESTING AND SUBSEQUENT SYSTEM REPAIR, IT IS STRONGLY RECOMMENDED TO USE FULL-FACE SHIELD PROTECTION.**

• **WARNING! THE SPRAY ASSEMBLY INVOLVES A CHAIN DRIVEN ROTATION NOZZLE THAT MAY UNEXPECTEDLY ACTUATE. DO NOT ACCESS THIS AREA WITHOUT FIRST DEENERGIZING THE COMPLETE SYSTEM AS NOTED ABOVE.**

Installation

1. Remove the complete system from the pallet and **manually operate** outside of the press area. **This can be completed by connecting all components according to the hose connections as indicated in the images on the following page.** Once these hoses are connected, connect plant air to the valve package and manually actuate the air valves according to the system operating cycle. During manual operation, confirm that these components are set accordingly and that the spray volume and pattern is acceptable. If the settings specific to your operation are other than those recommended by AMCOL, they should be recorded and controlled for later access and training.

2. With the press in normal operation and while standing outside of the press guarding, observe potential areas for installation of the spray head, reservoir, and valve package. The nozzles will have to fit without being hit by moving components of the press. The valve package and reservoir will have to be outside the press guarding and ideally within sight of the operator and spray nozzle, but out of the general traffic area.

3. Deenergize, lock, and tag the press, then place the spray head nozzle in the expected position (with no hoses attached) to properly assess the exact placement of this assembly.

Exit the lock and tag area and reactivate the press with the nozzle in position in order to determine that the nozzle is in a position to avoid damage during normal press operation. The rotating assembly should be centered to a billet 3" - 4" from the billet face. Once the exact location is determined, mark the location, and permanently install using the mounting holes.

4. Mount the valve package at eye level using the four mounting holes on the back plate. Position the reservoir below the valve package as shown on page 3.

5. Connect a lightly lubricated ½" air-line to the air inlet of the valve package. Be sure that this air source is properly locked and tagged prior to beginning your installation. Do not energize until all hoses have been properly installed and attached.

6. Reconnect hoses as supplied with the system. Numbers on each hose are included to indicate the correct connection.

- Hose 1 – Plant air from valve package to reservoir air inlet manifold**
- Hose 2 – Liquid from reservoir to liquid safety switch on valve package**
- Hose 3 – Liquid (U) from 034 Atomizer (formerly 025) returning to reservoir return port**
- Hose 4 – Regulated air to atomizing air (A) on 034 Atomizer (formerly 025)**
- Hose 5 – Liquid (L) from valve package to atomizer on the overspray cover**
- Hose 6 – Air from lubricator on valve package to air motor on overspray cover**
- Hose 7 – Air from valve package to air pilot (P)**

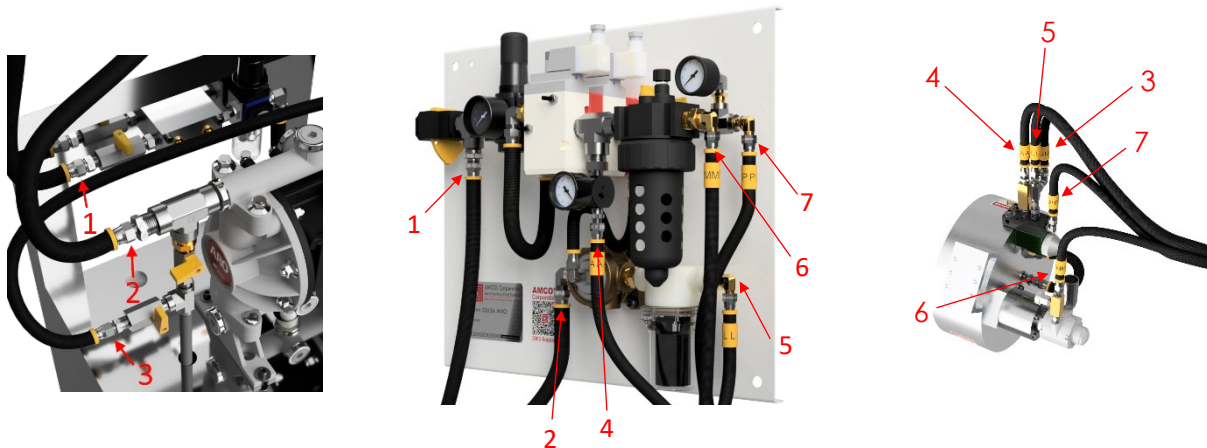

7. Fill air motor lubricator with an ISO 32 VG oil (such as 6401 Monolec® R&O Compressor Oil from Lubrication Engineers).

8. Energize the air source and manually operate the valve package as outlined in the system operating cycle.

9. Assuming the system is now operational, and the system settings are acceptable, deenergize the air to the valve package and finalize the PLC connection of the Norgren three-way valves located on the valve package to the press PLC with the sequencing timing. See Section 4 Recommended Settings.

10. Reenergize the air source to the valve package, and the spray system should be operational in automatic mode.

4 Operation

System Operating Cycle

1. **System Idle and Ready to Spray** – System Air Pressure (B) is steady at 60 PSI and the double diaphragm pump cycles once every 2 seconds.

2. **Energize Air Timing Valve (C)** – The Atomizing Air Pressure (E) will immediately go to 40 PSI and hold steady. The System Air Pressure (B) will remain virtually unchanged at 60 PSI. The spray head will begin rotating and the air (no liquid) will be coming out of the spray tips. If there is any liquid during this part of the spray cycle, there are issues with the valve sequencing or valve closure at the end of the prior cycle.

3. **Energize Liquid Timing Valve (D)** – After 0.5 seconds, energize the LTV. The Air Pilot Pressure Monitor (H) will immediately match the System Air Pressure (B). The Liquid Safety Switch and pilot on 034 Atomizer (formerly 025) are both open, thus allowing liquid through the flow restrictor, into the air stream in the atomizer, through the spinner head and spray tubes, and out of the spray tips.

4. **Deenergize Liquid Timing Valve (D)** – After 0.75 seconds, deenergize the LTV. The Air Pilot Pressure Monitor (H) will immediately go to 0 PSI. The Liquid Safety Switch and 034 Atomizer (formerly 025) are now closed.

5. **Liquid Cleanout of Spray Head** – Liquid in the 034 Atomizer (formerly 025), spinner head, spray tubes, and spray tips is now cleaned out completely, prior to ending the spray cycle. This part of the spray cycle takes 2 seconds when the system and its components are operating properly.

6. **Deenergize Air Timing Valve (C)** – The Atomizing Air Pressure (E) will immediately go to 0 PSI, and the rotating head will immediately stop. There should be no liquid dripping from the spray tips.

7. **System Idle and Ready to Spray** – System Air Pressure (B) is steady at 60 PSI and the double diaphragm pump cycles once every 2 seconds.

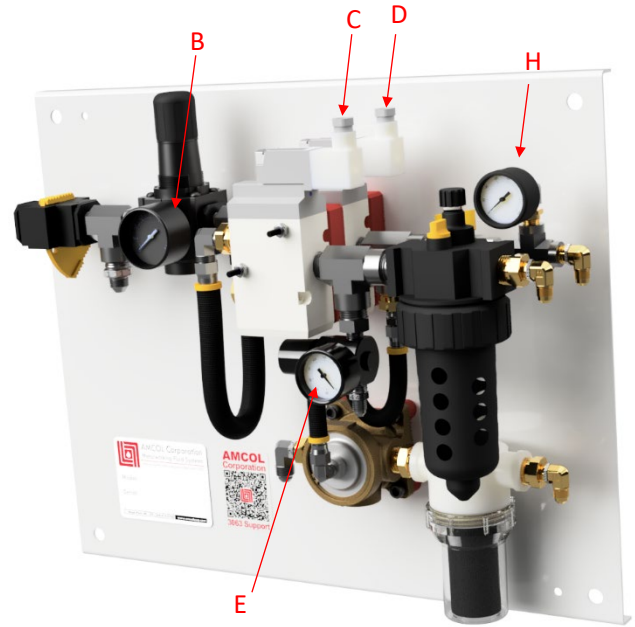

This process is repeated during each spray cycle. Simple ladder logic using Connected Components Workbench with an Allen Bradley Micro810 PLC can be seen below.

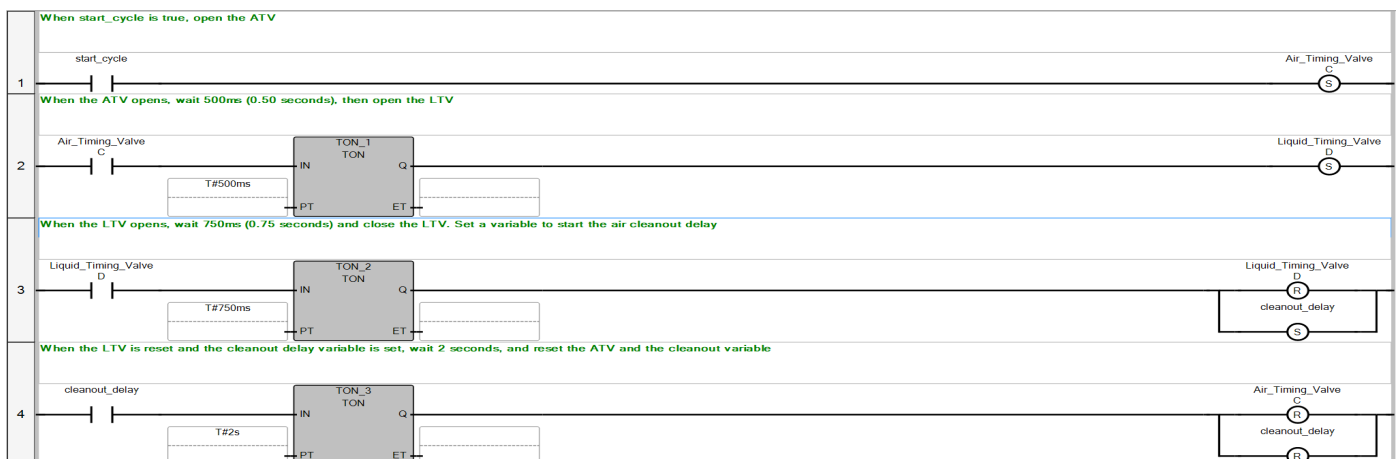

034 Atomizer

The new 034 atomizer operates using a flow restrictor design to meter fluid output, which is then controlled by an air piloted poppet assembly.

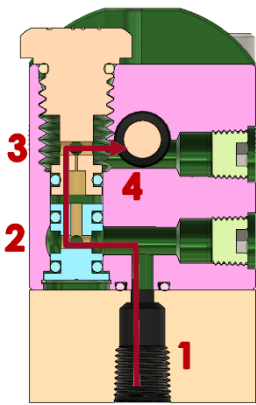
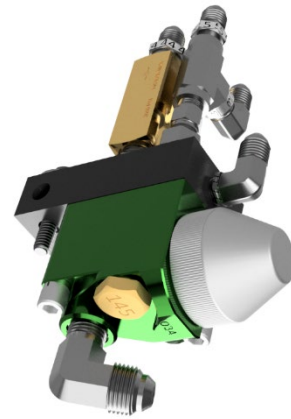

When the liquid safety switch on the valve pack is opened, fluid enters through the liquid inlet port (1), travels through the brass nozzle metering seat (2), flows upward into the 0145-flow restrictor (3), and fills the poppet assembly chamber (4).

When the air pilot valve is opened, air is supplied to the pilot port on the atomizer, forcing the poppet open. This allows the metered liquid to flow

through the nozzle seat (5) and into the atomizing air stream, which travels out of the atomizer, through the spinner assembly, and out of the spray nozzles.

When the air pilot valve is closed, the poppet assembly spring returns to the closed position, stopping fluid output from the atomizer.

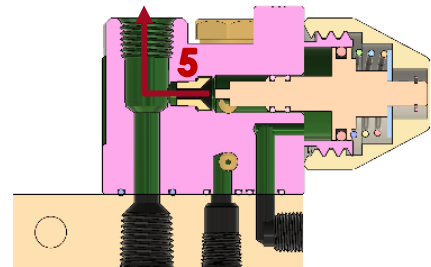
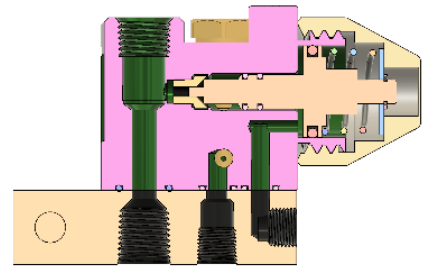

This new design also shares components with the 204 Atomizer for the 3049 Shear Sprayer system and greatly improves repairability. Unscrewing the gray poppet cap allows the entire poppet assembly to be easily removed for rebuilds or replacements.

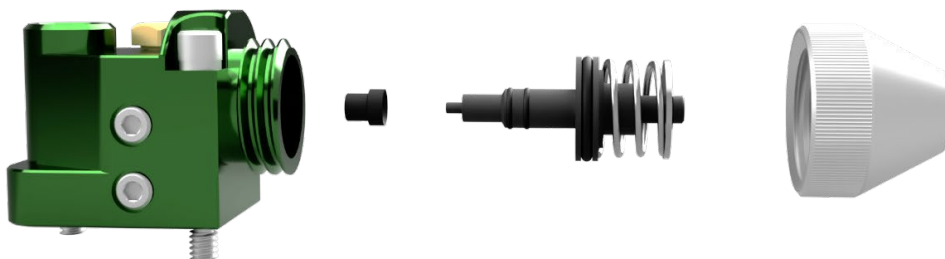

Liquid Air Purge

The Liquid Air Purge is an accessory that allows for manually actuated pumping of the liquid from the reservoir, through the valve package, to the 034 Atomizer (formerly 025), and back to the liquid reservoir. The purpose of this function is to remove any air pockets from any point in the liquid line. To complete the process:

1. Close the Air Pilot Line using the Air Pilot Shutoff (F).
2. Manually actuate the Liquid Timing Valve (D). The Air Pilot Pressure Monitor should read 0 PSI.
3. Close the Fluid Recirculation Ball Valve (J).
4. Open the Air Purge Return Valve (K) on the liquid reservoir.
5. Open the reservoir top to observe the fluid as it is returned from the 034 Atomizer (formerly 025).
6. Manually actuate the Liquid Timing Valve (D) while observing the liquid as it is returned back to the reservoir. The liquid flow may become sporadic or inconsistent. Continue this procedure until the flow is continuous and consistent. Liquid should shut off immediately when the Liquid Timing Valve (D) is deactivated.
7. Close the Liquid Air Purge Valve (K) located on the liquid reservoir.
8. Open the Fluid Recirculation Ball Valve (J) to <10% open as indicated in the recommended system settings.
9. Reopen the Air Pilot Shutoff (F) before operating.

The same process can be used to troubleshoot all three valves associated with the Liquid Spray Timing.

5 Recommended Settings

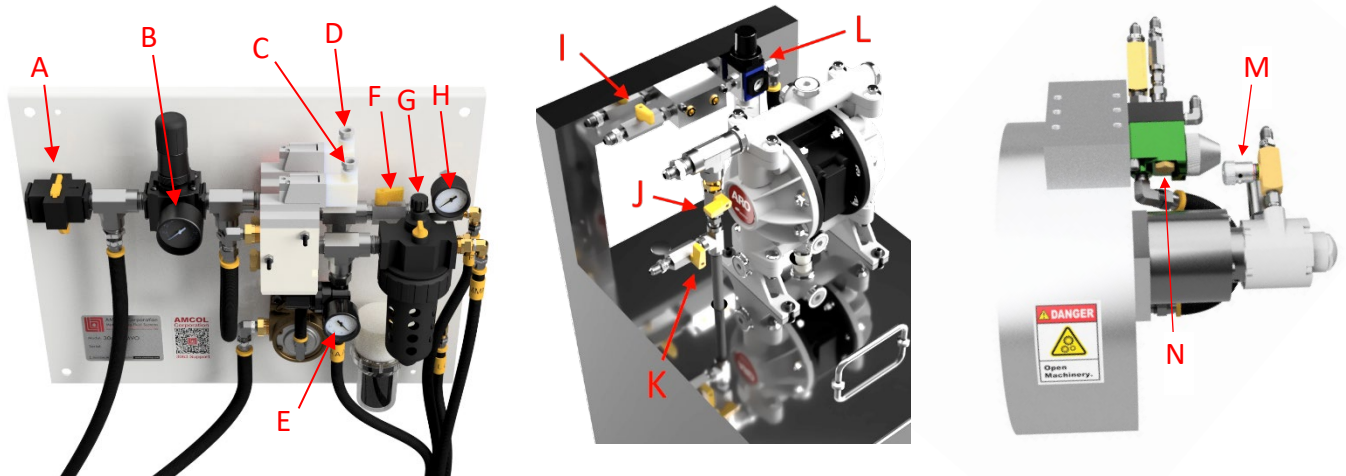

Item ID	Description	Recommended Settings
A	System Shutoff	Open during normal operation – Close to perform repairs. Has lock and tag eyelet.
B	System Air Pressure	60 PSI. This is the valve package inlet pressure. It can be set with no valves energized.
C	Air Timing Valve (ATV)	Energize for at least 0.5 seconds before energizing the Liquid Timing Valve (D), and leave energized until 2.0 seconds after deenergizing the LTV. Actuating this valve sends air through the atomizer to the spray tips. It will also send air to the motor used to drive the spinner.
D	Liquid Timing Valve (LTV)	At least 0.5 seconds after energizing the Air Timing Valve (C), energize the liquid timing valve for 0.75 seconds or more. Limit the time to 3 rotations of the spinner. This valve is used to open the liquid safety switch on the valve package and the air pilot located on the 034 Atomizer (formerly 025).
E	Atomizing Air Pressure	40 PSI. This is the air pressure used to atomize and propel fluid at the spray tips on the spinner head.
F	Air Pilot Shutoff	Open during normal operation. Closed only when completing Liquid Air Purge procedure (see section 4).
G	Air Motor Lubricator	1.0. This setting is used to define flow rate of an oil lubricant (ISO 32 VG Oil such as 6401 Monolec® R&O Compressor Oil from Lubrication Engineers or similar) to the air motor, which requires only minimal oil in the air to avoid seizing of the motor.
H	Air Pilot Pressure Monitor	Set using System Air Pressure (B). This gauge is for monitoring and troubleshooting only. In the event that this gauge is reading something other than the System Air Pressure, or that it is moving slowly during the Liquid Timing (D) sequence, there is a system malfunction.
I	Pump Shutoff	Open during normal operation. Allows for quick shut off of reservoir pump in the event of an emergency involving a leaking valve, hose, or strainer.
J	Fluid Recirculation Ball Valve	<10% Open (30 cycles per minute). This valve adjusts the recirculation flow back to the reservoir and pressure to the nozzle. As this valve is opened, the flow rate to the reservoir increases, while the liquid pressure to the nozzle is reduced.
K	Air Purge Return Valve	Closed during normal operation. This valve is used to purge the liquid line of any air that may enter as a result of changing or cleaning the filter, or repairing/replacing any liquid connections.
L	Pump Inlet Pressure	45 PSI. Increase pressure to increase liquid volume. This will increase pump flow and outlet pressure. Liquid pressure at the 034 Atomizer (formerly 025) must be at or above the Atomizing Air Pressure (E) in order to avoid back pressure inconsistencies.
M	Air Motor Speed Control	3.0 turns from closed. This adjustment is used to set a specific rotational speed of the spinner nozzle using air flow rate to the air/gear motor. Set by adjusting tight in the clockwise direction and then rotating in a counterclockwise (opening) direction.
N	034/025 Atomizer with Flow Restrictor	Not adjustable. Air and liquid are mixed within the 034 Atomizer (formerly 025) body (034 green/025 red) which also has an internal air pilot. Liquid output is determined based on the size of a machined port vs pressure (standard injector is 0.0145").

6 Maintenance

Recommended Spares

	Description	Part Number	Quantity
	034 Atomizer with 0.0145 Fixed Orifice and Fittings	3063A-034C *	1 each
	034/204 Rebuild Kit	A4008279	1 each
	034 0.0145 Flow Restrictor w/O-Rings	A3031801-AC0145	1 each
	Clean Out Tool, 0.0145" (0.3683mm)	2841A84*	1 each
	034 Flow Restrictor O-Ring Kit	034-FR-OK *	1 each
	Spinner Nozzle with Triple Seal	025-SNTS	1 each
	P/H Fire Res. Hose (1/4")	821FR-4-BLK**	50 feet
	P/H Fire Res. Hose (3/8")	821FR-6-BLK**	5 feet
	Rebuild Kit for 66605J-34B Diaphragm Pump (1)	637140-4B	1 each

	Check Balls, 3/4" PTFE, for 66605J-34B DP (1)	93100-4	4 each
	3 Way Poppet Valve with Coil	Special per Voltage	2 each
	Solenoid for Poppet	Special per Voltage	2 each
	140 PSI Pressure Gauge (1/8" Back Mount)	18-013-212	1 each
	160 PSI Pressure Gauge (1/4" Back Mount)	18-013-209	1 each
	Gear Motor Extension for Chain Drive with Screws	12-GME-C-AC*	1 each
	Clear Bowl for 1/2" Inline Strainer with Gasket	9875K11-AC*	2 each
	80 Mesh Replacement Screen for T-Strainer (SS)	9875K82	1 each



1/2" Polypropylene Pump
with PTFE Check Balls (1)

66605J-34B-AC

1 each

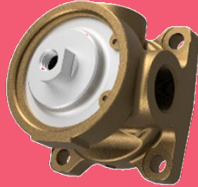

Liquid Safety Switch

01285-HMY

1 each



ISO 32 VG Oil (such as
6401 Monolec® R&O
Compressor Oil from
Lubrication Engineers)

N/A*

1 gallon

* Strongly recommended
** May be purchased locally
(1) Note: PTFE replaces Santoprene™

Preventative and Predictive Maintenance

Daily

- Observe fluid level and fill as necessary.
- Check fluid dilution using Misco PA201 Digital Refractometer (information regarding the Misco PA201 can be found on pg. 15). Correct dilution as necessary.
- Observe all air pressure settings and gauges to be consistent as per the liquid and air timing sequence. Use these gauges to confirm that all air valves are properly opening and closing. System air should never significantly change as each valve opens and closes.
- Observe ½" Inline Strainer for sediment and solids. Clean or replace strainer (80 Mesh Replacement Screen) if required. Identify root cause.
- Observe spray alignment, quality, and quantity. Make any adjustments or repairs as necessary.
- Observe the Air Motor Lubricator. Fill as necessary with an ISO 32 VG Oil (such as 6401 Monolec® R&O Compressor Oil from Lubrication Engineers).

Quarterly

- Completely empty reservoir. Wash with water. Refill.
- Change Clear Bowl and Gasket for ½" Inline Strainer.
- Inspect Check Balls, ¾" PTFE, for 66605J-34B Diaphragm Pump.

Yearly

- Replace 034 atomizer (formerly 025) with Fixed Orifice and Fittings and Spinner Nozzle with Triple Seal assembly.
- Replace all air regulator pressure gauges.
- Replace all liquid and air hoses.
- Rebuild or replace double diaphragm pump.
- Replace Air Motor Assembly with Gear Reducer and Roller Chain.
- Disassemble, inspect, and repair or replace the three-way air operated solenoid valves on valve package.

7 System Troubleshooting

Check in order as listed.

No Liquid

- The reservoir is empty or low. Pump will pulse very fast with this condition.
- System Air Pressure (B) is too low during spray cycle. Adjust to 60 PSI. Be sure to observe the gauge before and during the spray cycle. The gauge pressure should not in any way be affected by the air consumed by the diaphragm pump during the spray cycle; if this occurs, the main air supply is somehow limited and does not offer enough flow for proper operation of the system. Troubleshoot main air supply.
- Fluid Recirculation Ball Valve (J) on reservoir not restricted, or Air Purge Return Valve (K) is open. Fluid pressure will be too low to overcome the Atomizing Air Pressure (E). Adjust.
- Air has inadvertently entered the liquid line. Complete air purge of the liquid line (see section 5).
- The Safety Switch is not opening. This can be tested by closing Air Pilot Shutoff (F), closing Fluid Recirculation Ball Valve (J), opening Air Purge Return Valve (K), and manually actuating Liquid Timing Valve (D). Fluid will circulate freely and continuously back to the reservoir.
- 034 Atomizer (formerly 025) (N) is not opening, or Flow Restrictor is clogged. Check that the Air Pilot Pressure Monitor (H) reads 60psi. **Depressurize and lock and tagout the complete system prior to any work.** Remove the Flow Restrictor and clean using #2841A84: Clean Out Tool (or a 0.0145" drill bit or brush). Use a light oil on the O-ring to facilitate reinstallation.

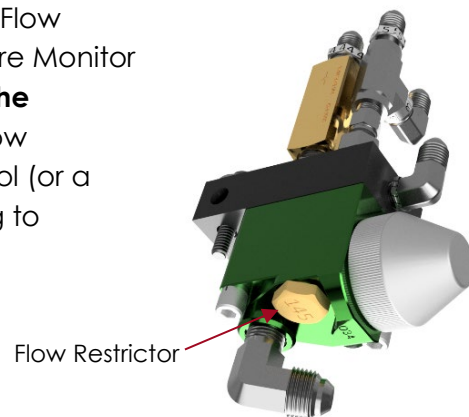

- The air pump on the reservoir is malfunctioning. Open Fluid Recirculation Ball Valve (J) and allow pump to operate. There should be a steady pulsating flow of liquid with no leaking of air or liquid from the pump itself. Refer to pump manual (Model 66605J-34B Aro Ingersol Rand) for repair and troubleshooting.

Too Much Liquid

- Liquid safety switch and 034 Atomizer (formerly 025) (N) are actuated for too long. Shorten Liquid Air Valve (D) timing.
- Pump pressure on reservoir (L) too high. Set to 45 PSI.
- Flow Restrictor has been bypassed due to a leaky, damaged, or missing O-ring, or from chemical erosion of the 034 Atomizer (formerly 025). Replace or repair as needed.

Too Little Liquid or Poor Coating

- Atomizing air pressure (E) is set too high. Adjust to 40 psi.
- 46 ILX EJECTEZE concentration is too diluted.
- Opposite of Too Much Liquid (as referenced above).
- Hose, filter, nozzle, or flow restrictor partially clogged.
- The location of the rotating head is too far away. Locate spray cover 4" from the face of the billet or block.
- Rotating head is not centered to the billet or block, or not appropriately sized for billet.

Fluid Runs on or Is Not Atomized During Part or All of the Spray Cycle

- Air Timing Valve (C) is not correct. Must be open during the complete spray cycle. A visual inspection of the Spray Pressure Regulator gauge (E) allows for a visual inspection of the timing sequence.
- Liquid Timing Valve (D) cycle is too long. Start after Air Timing Valve and close 2 seconds prior to the end of the Air Timing Valve sequence.
- Liquid Timing Valve is malfunctioning. Troubleshoot by first observing the Air Pilot Pressure Monitor (H) to ensure pressure goes up and down quickly with the actuation of the Liquid Timing Valve.
- Liquid Safety Switch is malfunctioning. Follow the Liquid Air Purge as directed in section 5. After manual actuation has ended, the pump should be quickly shut down.
- 034 Atomizer (formerly 025) (N) is not properly closing. Disassemble, clean, or replace.

PA201 Refractometer

The PA201 Refractometer, manufactured by Misco, is a handheld testing instrument used to check and monitor dilution ratios of liquid concentrates that are mixed with water. It is operated by placing a drop or two of fluid in the titanium bowl, then pressing the activation button. A microprocessor will then deliver a nearly instantaneous digital readout on an LCD display.

This numerical reading can be correlated to a specific dilution for a given product using a cross reference chart or logarithmic formula.

Calibration is automatic and does not require the use of special calibration solutions or tools. See the Misco PA201 Refractometer reference manual for additional information.

The Misco PA201 Refractometer is based on the Brix scale reading system. There are many different types and makes of Refractometers that can be used as a substitute. Be sure that whatever system is used is reliable and easy to operate.



Item ID:
PA201-EJECTEZE

For optimal performance, AMCOL Recommends:

46 ILX EJECTEZE

Release Agent for Non-ferrous Extrusion

Proven technology, refined over decades.



8 System Schematics

3063A-BSR, 3063A1-BSR, 3063A2-BSR

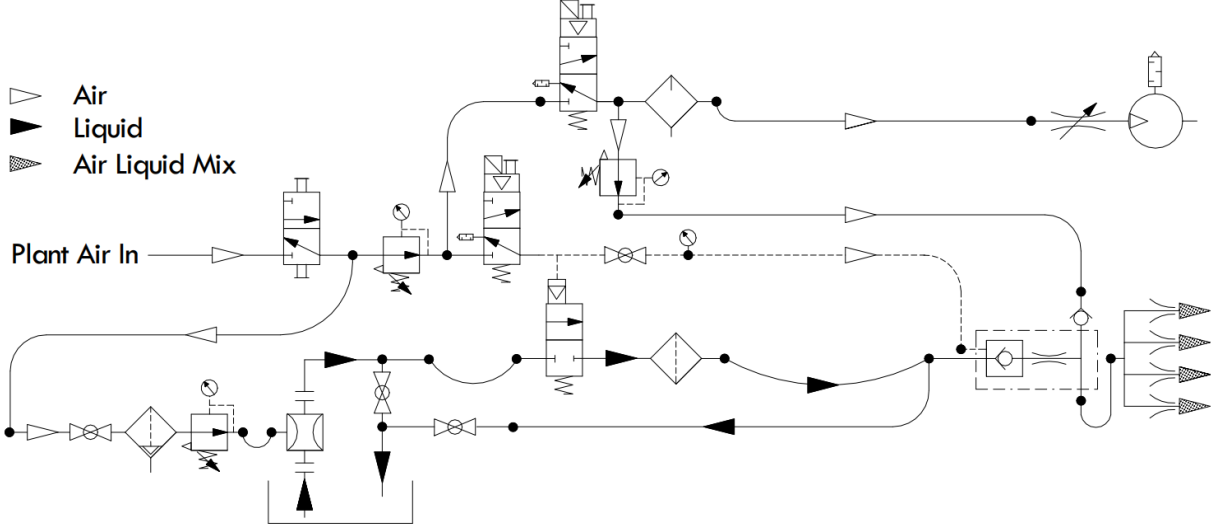

9 Drawings

Spray Head

3063A-034SP-10 (updated version)

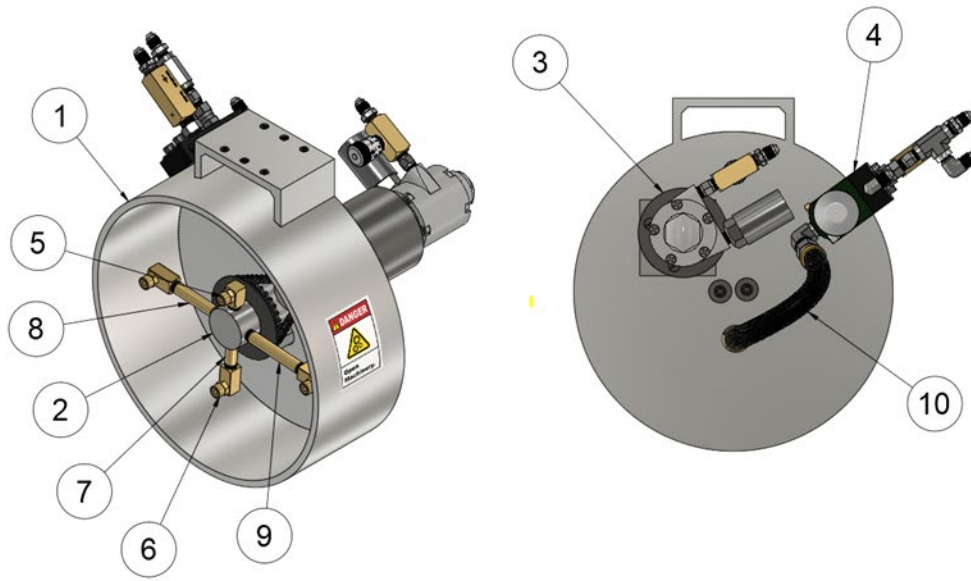

PARTS LIST		
ITEM	QTY	PART NUMBER
1	1	BL COV-10-AC
2	1	13-SNTS-HS-C
3	1	14-AMA-GR
4	1	3063A-034C
5	1	WT4070M-01225-C
6	3	FWT4070-01225-C
7	1	215PNL-2-15
8	1	215PNL-2-25
9	1	215PNL-2-30
10	1	SP-HOS

3063A-025SP-10 (older version)

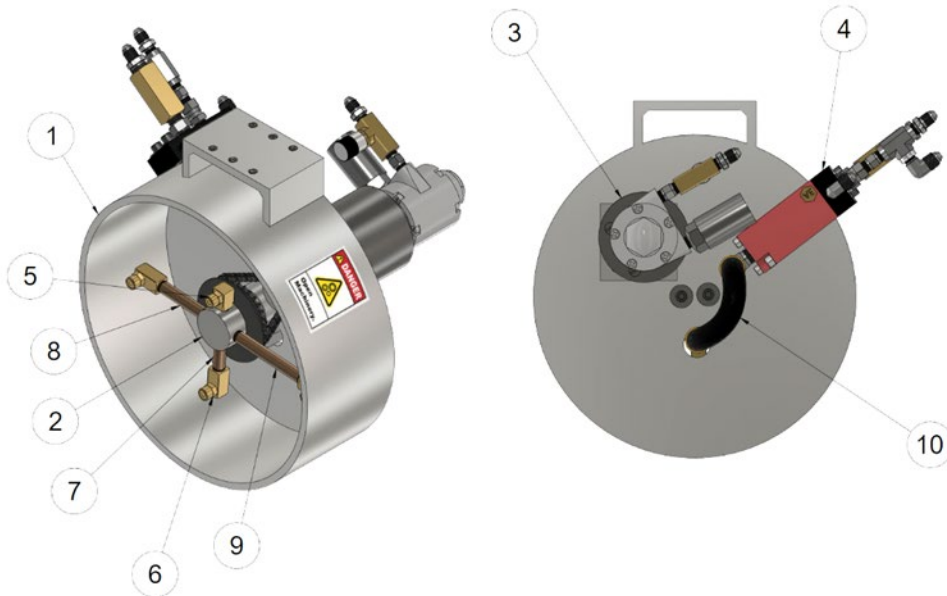

PARTS LIST		
ITEM	QTY	PART NUMBER
1	1	BL COV-10-AC
2	1	13-SNTS-HS-C
3	1	14-AMA-GR
4	1	3063A-025C
5	1	WT4070M-01225-C
6	3	FWT4070-01225-C
7	1	4501K11-AC1.5
8	1	4501K11-AC2.5
9	1	4501K11-AC3.5
10	1	SP-HOS

Atomizer

3063A-034C (updated version)

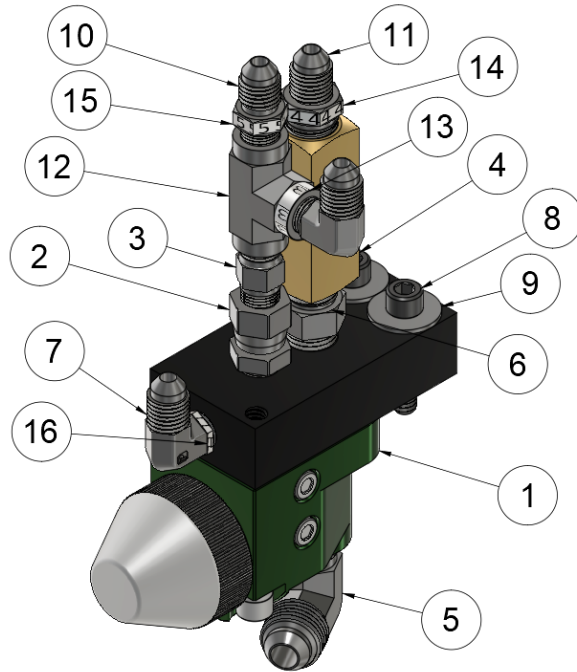

PARTS LIST		
ITEM	QTY	PART NUMBER
1	1	034-0145-AC
2	1	0107-2-2
3	1	2-PC-11
4	1	JC-2
5	1	6-37-6
6	1	4-PC-11
7	2	4-37-6
8	2	25C125SHC
9	2	25NUFW
10	1	4-37-2
11	1	4-4-37-2
12	1	2-PC-25
13	1	MMMSDR3
14	1	MMMSDR4
15	1	MMMSDR5
16	1	MMMSDR7

034 Atomizer (Internal View)

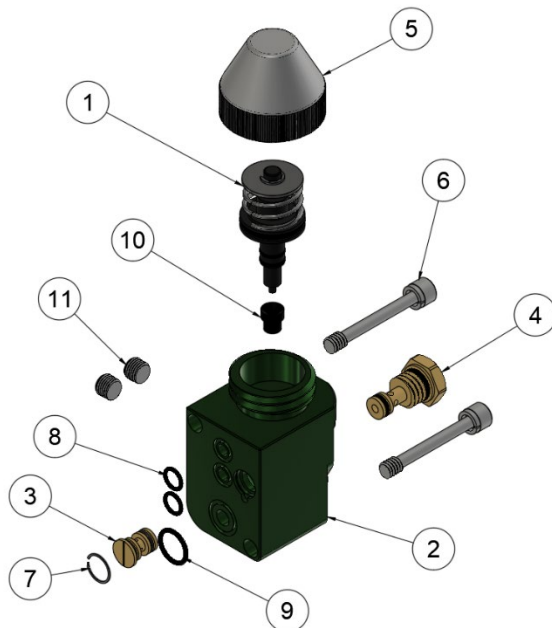

PARTS LIST			
ITEM	QTY	PART NUMBER	DESCRIPTION
1	1	A4005642	PISTON ASSEMBLY
2	1	A3026995-A	034 BODY
3	1	A4005667	0X4 SERIES NOZZLE METERING SEAT
4	1	A3031801-AC0145	034 3A FLOW RESTRICTOR
5	1	A3027000	POPPET CAP
6	2	A2022499	SS SHCS 1/4-20 - CAPTIVE BOLT
7	1	A2020940	RETENTION CLIP
8	2	A2023024-2-010	2-010 VITON O-RING
9	1	A2023024-2-013	2-013 VITON ORING
10	1	A3031488	NOZZLE SEAT VITON
11	2	01048-D	PIPE PLUG 1/16" NPT SS

3063A-025C (older version)

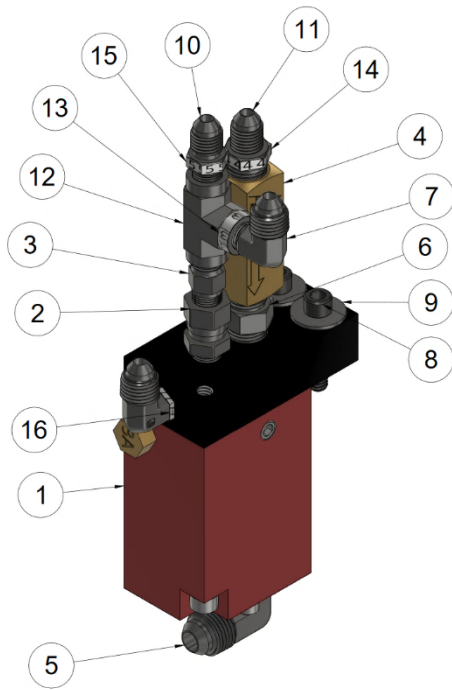

PARTS LIST		
ITEM	QTY	PART NUMBER
1	1	025-1-00000-DNA#3AAC
2	1	0107-2-2
3	1	2-PC-11
4	1	JC-2
5	1	6-37-6
6	1	4-PC-11
7	2	4-37-6
8	2	25C125SHC
9	2	25NUFW
10	1	4-37-2
11	1	4-4-37-2
12	1	2-PC-25
13	1	MMMSDR3
14	1	MMMSDR4
15	1	MMMSDR5
16	1	MMMSDR7

Air Motor Assembly

14-AMA-GR

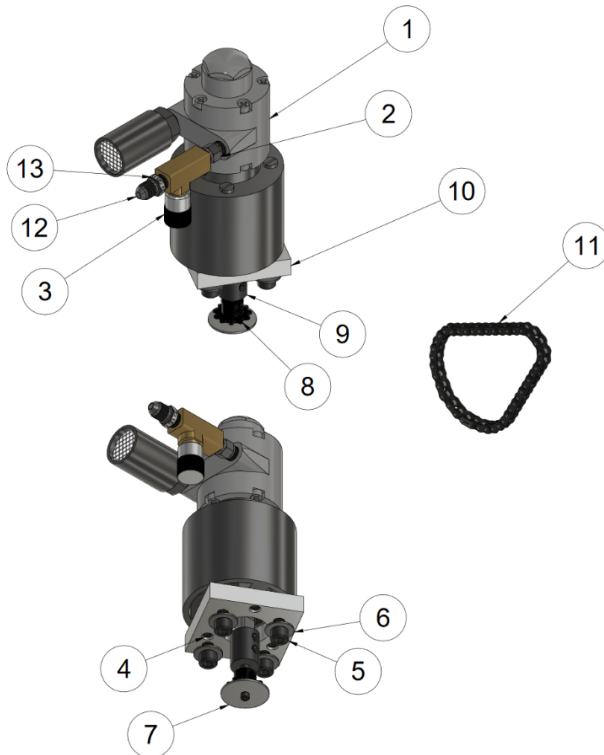

PARTS LIST		
ITEM	QTY	PART NUMBER
1	1	1UP-NRV-11-GR11-AC
2	1	2-PC-11
3	1	JN-1
4	3	10F50SHC
5	4	31C75SHC
6	4	25NUFW
7	1	6ULA7
8	1	25B11-AC
9	1	12-GME-C-AC
10	1	AGMMP
11	1	230C10300-AC21
12	1	4-37-2
13	1	MMMSDR6

Spinner Assembly

13-SNTS-HS-C

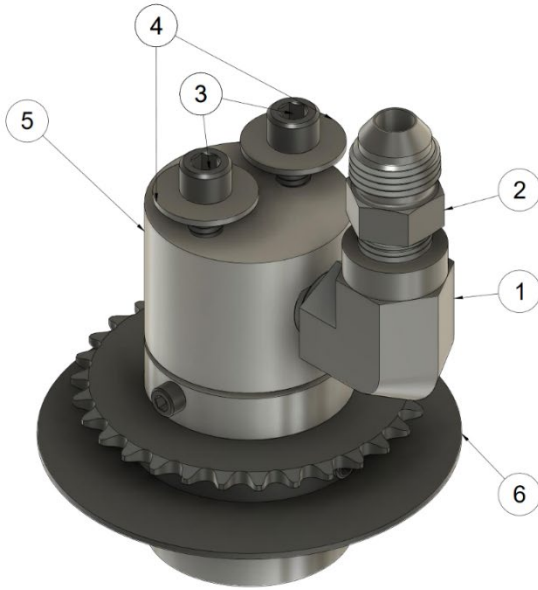

PARTS LIST		
ITEM	QTY	PART NUMBER
1	1	4-PC-18
2	1	6-37-2
3	2	25C62SHC
4	2	25NUFW
5	1	025-SNTS
6	1	30-25KW-AC

Reservoir

3063A-NP30

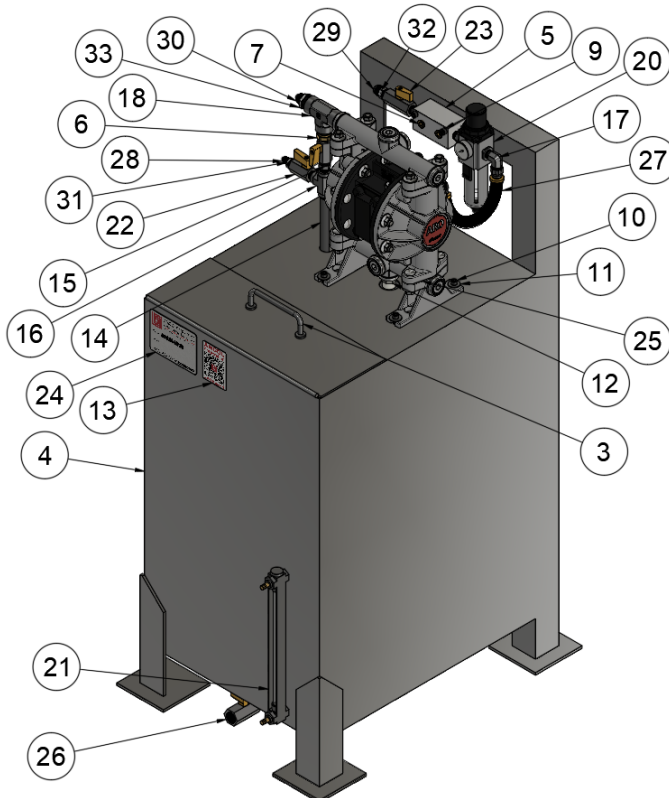

PARTS LIST			PARTS LIST		
ITEM	QTY	PART NUMBER	ITEM	QTY	PART NUMBER
1	1	001543	17	1	6-37-6
2	1	015112-AC7	18	1	8-PC-25
3	1	11665A21	19	1	9563K46
4	1	2000-R30-TANK-AC	20	1	B07-202-M1KA
5	1	201-1	21	1	B-1579-1
6	1	209P-8-4	22	2	MV608-4
7	2	219P-4	23	1	MV609-4
8	6	25CNNEZ	24	1	2-SEP
9	2	25C225SHC	25	1	66605J-34B-AC
10	4	25C87SHC	26	1	MV609-8
11	4	25NUFW	27	1	FR8A-0.75
12	1	44875-AC2	28	1	4-4-37-2
13	1	LABEL-3063 SUPPORT	29	1	6-37-2
14	1	4885K41-AC1	30	1	6-8-37-2
15	3	4-PC-11	31	1	MMMSDR3
16	1	4-PC-25	32	1	MMMSDR1
			33	1	MMMSDR2

Valve Package

3063A2-MVO

PARTS LIST			PARTS LIST		
ITEM	QTY	PART NUMBER	ITEM	QTY	PART NUMBER
30	1	LABEL-3063 SUPPORT	1	3	005297
31	1	01285-HMY	2	1	01140
32	2	VP742-SPACER	3	1	18-013-212
33	2	91251A907	4	1	209P-4.2
34	2	10FNNMZ	5	5	209P-8.4
35	2	9833K11	6	1	216P-8
36	1	01285-HMY-SPACER	7	1	2P132
37	4	31C150SHC	8	1	2-PC-18
38	4	31CNNEZ	9	1	342-25-020
39	1	4-37-6	10	1	48115K85
40	2	30682-4-4	11	1	4-PC-25
41	1	821FR-4-BLK	12	2	6-37-6
			13	2	6-8-37-2
			14	2	8-4-PC-11
			15	4	8-PC-24
			16	1	HOA-24P20-AC2
			17	1	L606-04W
			18	1	MV608-8
			19	1	2-SEP
			20	2	VP742-5DZ1-04TA
			21	3	149F-4.4
			22	2	4-4-37-2
			23	1	MMMSDR4
			24	1	MMMSDR2
			25	1	MMMSDR1
			26	1	MMMSDR6
			27	1	MMMSDR5
			28	1	MMMSDR7
			29	1	SP-HOS

Mounting

13-FPOCM1

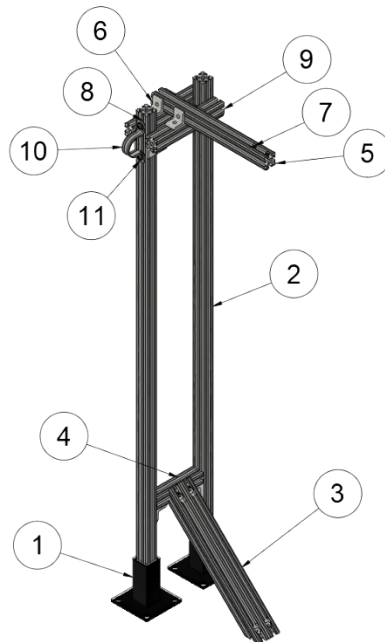

PARTS LIST		
ITEM	QTY	PART NUMBER
1	2	EB-41
2	2	47065T103-60
3	1	47065T706
4	1	47065T103-6.5
5	1	47065T103-16-FPOCM
6	10	47065T845
7	2	31C150SHC
8	2	47065T229
9	2	47065T103-9.5
10	1	9429T39
11	4	25NUFW

Hand Spray Wand Attachment

Attachment Kit: 020-NPV-C

(020-00048: Hand Spray Wand w/ hoses sold separately)

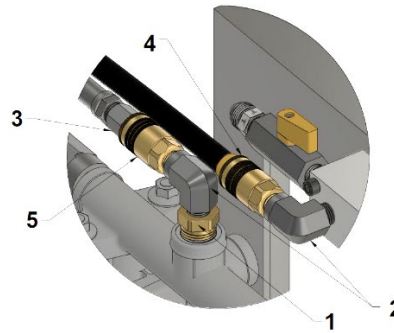
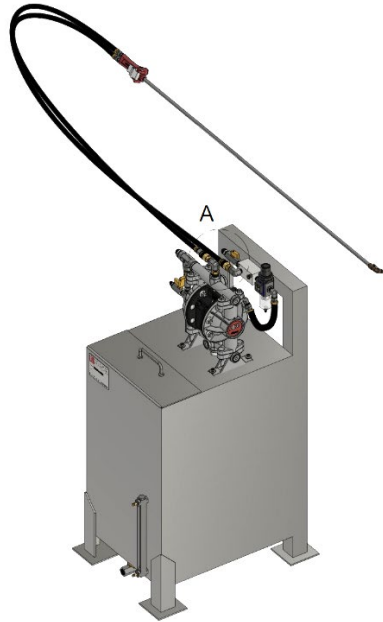

PARTS LIST		
ITEM	QTY	PART NUMBER
1	1	209P-3-4
2	2	4-PC-18
3	1	A3C
4	1	B-22
5	1	B-52

AMCOL
Corporation



3063 Support



AMCOL Corporation

21435 Dequindre, Hazel Park, MI 48030

248-414-5700

fax: 248-414-7489

www.amcolcorp.com