

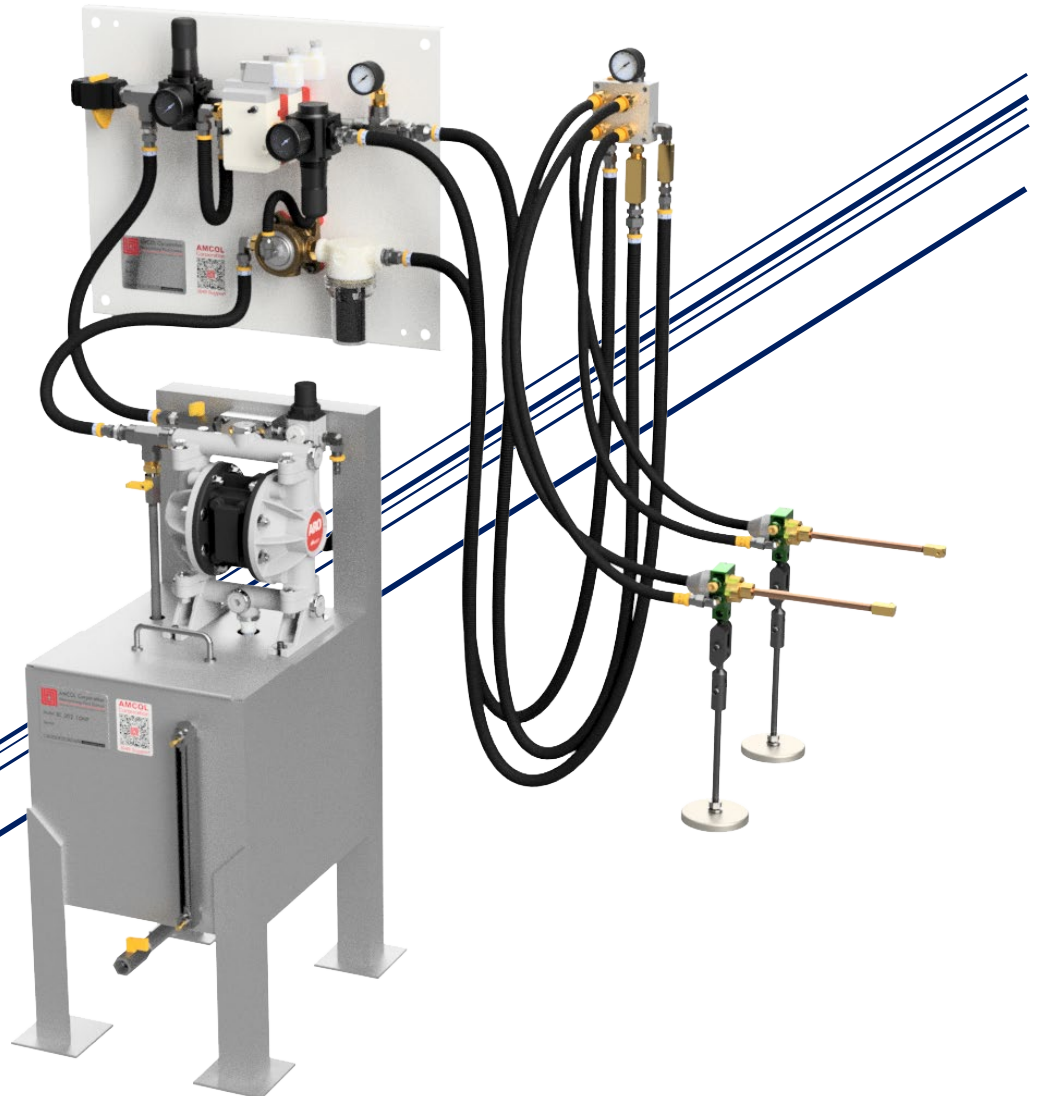

AMCOL CORPORATION
3049B AUTOMATIC BUTT
DISCARD LUBRICATION SYSTEM
OPERATOR'S MANUAL



Contents

1. Introduction	2
2. What Do I Have?.....	3
3. Assembly and Installation	4
PRIOR TO GETTING STARTED	4
Installation	5
4. Recommended Settings for 3049B with 202.....	8
4a. Recommended Settings for 3049B1 with 204	9
5. Operation	10
Cycle Timing	11
6. BL 463 2S EJECTEZE	12
PA201 Refractometer	12
7. System Troubleshooting	13
No Liquid	13
Too Much Liquid	13
Too Little or Inconsistent Liquid	13
Fluid Runs on After Spray.....	13
8. MRO Inventory	14
Recommended Spares.....	14
9. Maintenance	18
Preventative and Predictive Maintenance	18
Retrofitting the 01285-HMY Safety Switch	19
10. Schematics	20
System Schematic	20
202 Spray Nozzle - Discontinued	21
204 Spray Nozzle - Updated	22
Reservoir	23
Valve Package	23
Air/Liquid Manifold.....	24

1. Introduction

This operator's manual is designed to walk you through the installation, operation, and maintenance of your new AMCOL 3049B Spray System. For more information on the overview of the system and the individual components, please refer to the AMCOL 3049B Technical Description.

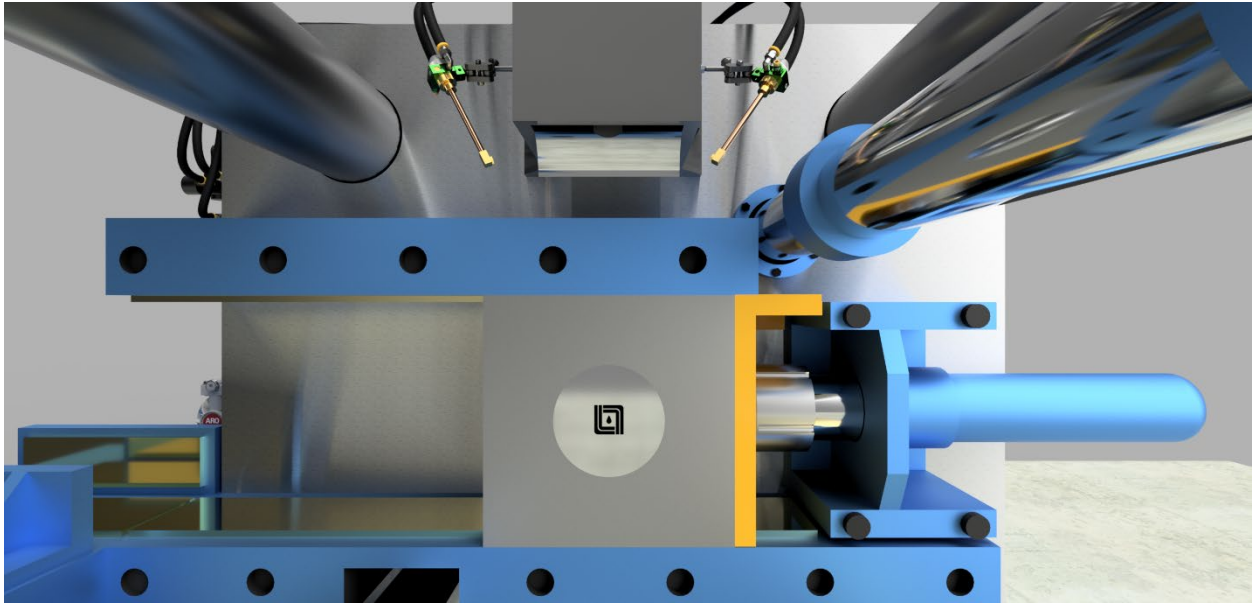

2. What Do I Have?

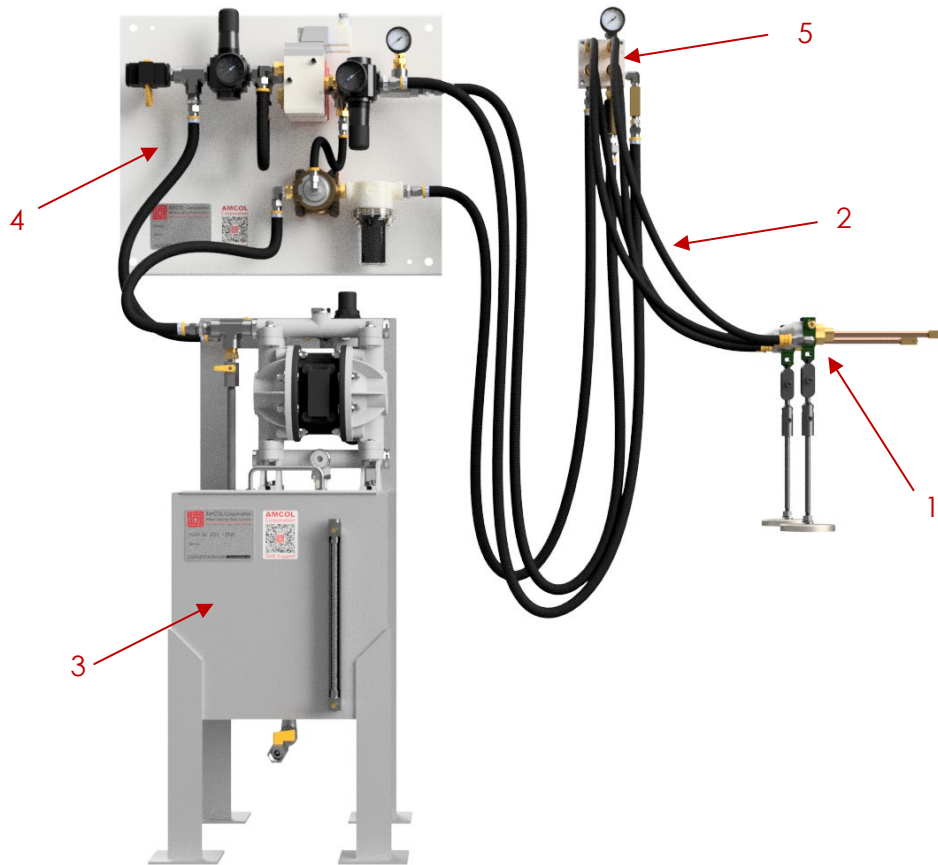

1. 2 ea. 202 or 204 Atomizing Spray Nozzles (*202 is being phased out*)
 - a. Spray Tips (90° Conical or Fan)
 - b. Brass Extensions
 - c. Multidirectional Mounting Bracket
 - d. Mounting Magnet
2. Hose
 - a. 2x 5' (Reservoir to Valve Package)
 - b. 2x 15' (Valve Package to Manifold)
 - c. 2x 7' (Manifold to Spray Nozzles)
3. Reservoir
 - a. 10 Gallon
4. Valve Package
 - a. 24VDC
 - b. 110VAC
 - c. 220VAC
5. Manifold
 - a. Gauge and quick connect fittings for hoses

3. Assembly and Installation

PRIOR TO GETTING STARTED

• PLEASE GO TO <https://amcolcorp.com/amcol-model-3049-set-up-video/> AND WATCH THE SET UP VIDEO.



- **WARNING! DO NOT DISASSEMBLE, REPAIR, OR REPLACE COMPONENTS OR SUBASSEMBLIES OF THIS SYSTEM WITHOUT FIRST DEENERGIZING THE SYSTEM AIR SOURCE WITH LOCK AND TAG; THIS CAN BE TESTED BY VISUALLY INSPECTING THE PRIMARY AIR GAUGE (B) ON THE VALVE PACKAGE TO BE AT 0 PSI AND MANUALLY ATTEMPTING TO ACTUATE EITHER THREE-WAY AIR VALVE ON THE VALVE PACKAGE.**
- **WARNING! BE SURE THAT THE PRESS IS PROPERLY GUARDED IN ORDER TO AVOID INADVERTENT OR UNINTENDED ACCESS TO THE SPRAY HEAD BY UNTRAINED PERSONNEL. REFERENCE ANSI B11.17 OR SIMILAR PRESS GUARDING STANDARDS.**
- **WARNING! BE SURE TO MOUNT THE RESERVOIR AND VALVE PACKAGE OUTSIDE OF THE GUARDED AREA, AS THEY WILL HAVE TO BE ACCESSED DURING NORMAL PRESS OPERATION.**
- **WARNING! DO NOT ATTEMPT TO ADJUST OR MODIFY NOZZLES, WHICH WILL BE WITHIN THE GUARDED AREA, WITHOUT DEENERGIZING THE PRESS WITH LOCK AND TAG.**
- **WARNING! THE SYSTEM IS NOT DESIGNED OR CAPABLE OF DISPENSING FLAMMABLE OR COMBUSTIBLE LIQUIDS.**
- **WARNING! USE PROPER EYE PROTECTION WITH SIDE SHIELDS WHEN IN THE AREA OF OPERATION. DURING TESTING AND SUBSEQUENT SYSTEM REPAIR, IT IS STRONGLY RECOMMENDED TO USE FULL-FACE SHIELD PROTECTION.**
- **WARNING! IN ORDER TO UTILIZE THE MAGNETIC SPRAY ASSEMBLY MOUNTING OPTION, THE MAGNET MUST BE CONNECTED TO A CLEAN FLAT STEEL SURFACE; IN THE EVENT THAT A FIRM MAGNETIC MOUNT IS NOT POSSIBLE, ELIMINATE THE MAGNET AND PERMANENTLY MOUNT THE NOZZLE ASSEMBLY USING THE BRACKET PROVIDED.**
- **WARNING! THIS SYSTEM IS OUTFITTED WITH A MAGNETIC SPRAY NOZZLE MOUNTING DESIGN IN ORDER TO AVOID CATASTROPIC DAMAGE TO THE NOZZLE WHEN IT IS INADVERTENTLY HIT (I.E. FLARE OUT). BE SURE TO PROPERLY DEENERGIZE THE PRESS WITH LOCK AND TAG IF REPLACING THE NOZZLES THAT HAVE BEEN INADVERTENTLY MOVED OR REQUIRE INSPECTION/MAINTENANCE. IN GENERAL, IT IS RECOMMENDED THAT EVENTUALLY, THE MAGNETIC MOUNT BE CONVERTED TO A PERMANENT THREAD MOUNT AND GUARDED SO AS TO AVOID THIS TYPE OF ACTIVITY ALL TOGETHER.**

Installation

1. Review complete system to ensure that damage has not occurred in shipment.

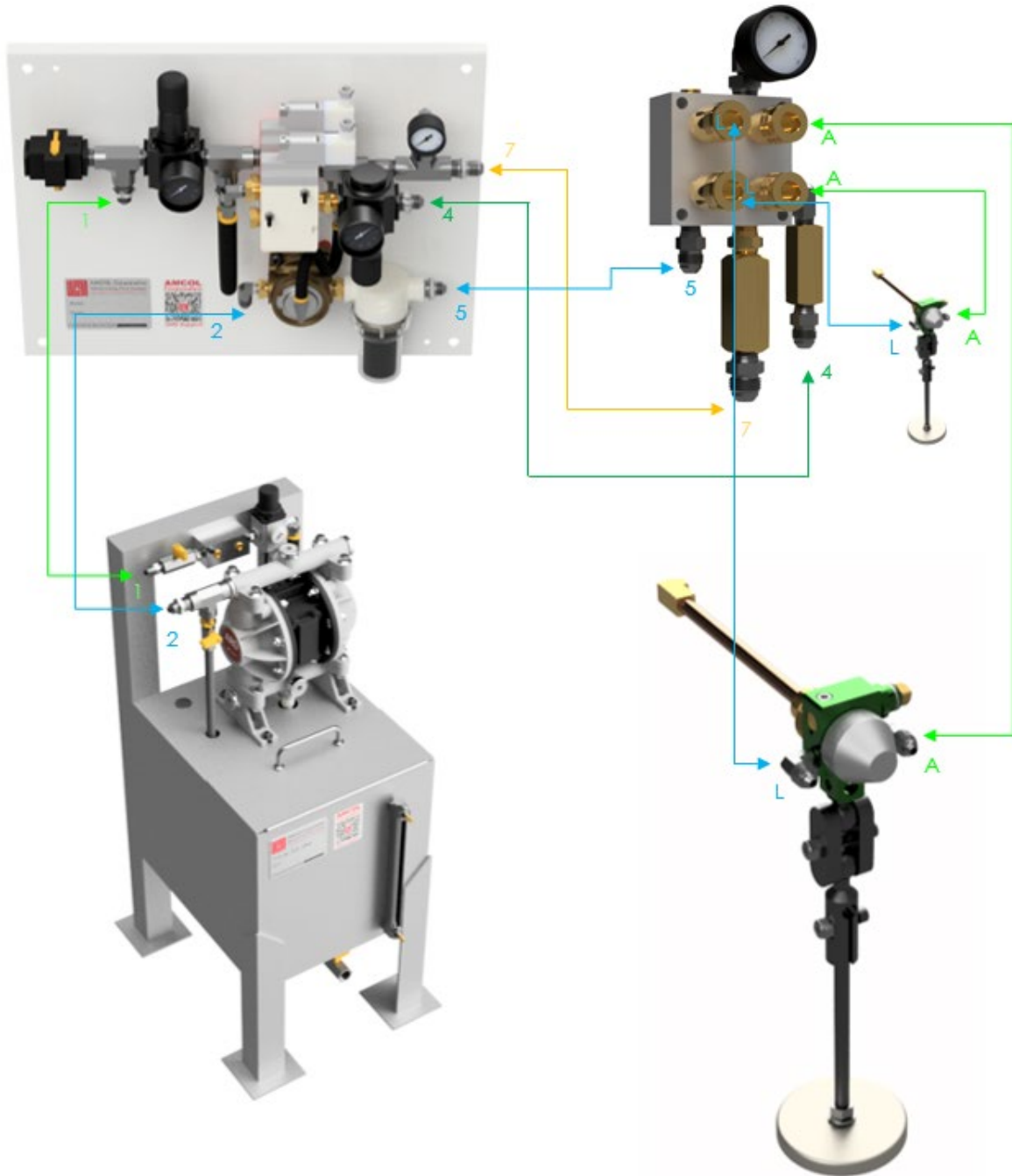

2. Manually operate the system outside of the press area. This can be completed by connecting all components as per the schematic provided, connecting plant air to the valve package, and then pressing the manual actuation buttons located on the side of the 3-way valves located on the Valve Package. All components will come in preset according to the System Settings recommended in this bulletin. During manual operation, it should be confirmed that these components are set accordingly and the spray volume and pattern is acceptable. If the settings specific to your operation vary from those recommended by AMCOL, these should be recorded and controlled for later access and training.

3. With the press in normal operating conditions and standing outside of the press guarding, observe potential areas for installation of the nozzles, reservoir, and valve package. The nozzles will have to fit without being hit by moving components of the press (typical installation is about 8-12" from the blade). The valve package will have to be outside the press guarding and ideally within sight of the operator and spray nozzles, yet out of general traffic area. The reservoir should also be outside of the press guarding and close to the valve package.

4. Lock and Tag the press. Then place the atomizing nozzle assemblies in the expected position without the hose attachments in order to properly assess and approve the exact placement of them. Exit the lock and tag area and reactivate the press with the nozzle in position in order to determine that the nozzle is in a position so as to avoid damage during normal press operation. Once the exact location is determined, mark the location or permanently mount the nozzles accordingly for future reference and placement after servicing or other movement of the nozzle and spray assembly. Hints for placement:

- A. Butt Shear – on the press platen, shear housing, or top of the container (with fan spray).
- B. Log Shear – on the press platen from the exit side of the shear.
- C. Spray pattern for 90° conical and straight fan tips can be seen in the table below.

Tip Type	Distance from Blade			
	3"	6"	9"	12"
90° Tip	2" OD Circle	3" OD Circle	3" OD Circle	4" OD Circle
Fan Tip	2" x 6" Rectangle	2" x 7" Rectangle	2" x 8" Rectangle	Not recommended

5. Permanently mount the liquid air manifold block above the spray nozzles such that it is located within seven feet (7') of both atomizers. Also, be sure the manifold block is visible from outside the lock and tag area to allow for system inspection and monitoring during normal press operation.

6. Mount the Valve Package as previously determined. The Valve Package air and liquid outlets must be within fifteen feet (15') of the liquid and air manifold, which has already been installed on the press.

7. Connect a lightly lubricated ½" air line to the air inlet of valve package. Be sure that this air source is properly locked and tagged prior to beginning your installation. Do not energize until all hoses have been properly installed and attached.

8. Connect hoses as supplied with the system. Any hose that is longer than required to make a proper connection should be shortened where possible.

9. Energize the air source and manually operate the Valve Package (as per directions in step 1).

10. Assuming the system is now operational, and the system settings are acceptable, de-energize the air to the Valve Package and finalize the PLC connection of the 3-way valves located on the Valve Package to the press PLC with the sequencing and timing. Be sure to spray the Butt Shear while the container is closed and the Log Shear while empty and in the Open Position. It is generally recommended that a manual actuation option is available from the press operator control station.

11. Reenergize the air source to the valve package, and the spray system should be operational in automatic mode.

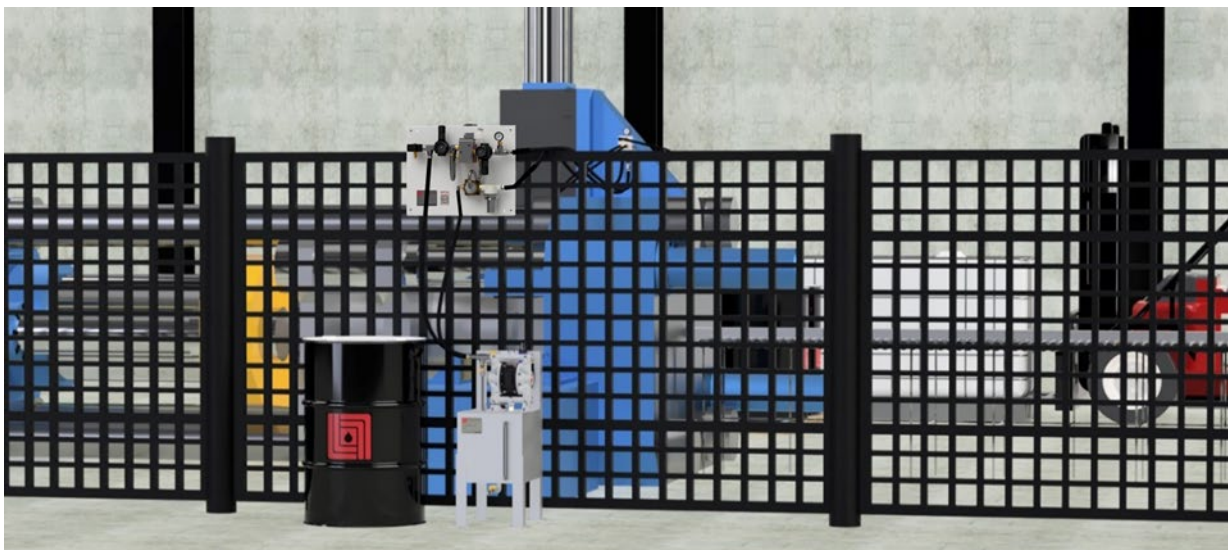

4. Recommended Settings for 3049B with 202

Item ID	Description	Recommended Setting (and Explanation)
A	System Shutoff	Open during normal operation – Close to perform repairs. Has lock and tag eyelet.
B	Spray Pressure Regulator	40 PSI. This is the valve package inlet pressure. It can be set with no valves energized. This air pressure determines spray pressure when the liquid and air are both energized.
C	Spray Valve (back valve)	Energize for the first 0.5 seconds and then deenergize. Actuating this valve opens liquid at the valve package (liquid safety switch) and air and liquid at the atomizing nozzle.
D	Blow Out Valve (front valve)	0.5 seconds after deenergizing the spray valve, energize the blow out valve for 2.5 seconds or more. This valve is used to clear the liquid from the spray tubes and will only supply air to the nozzle.
E	Blow Out Pressure Regulator	20 PSI. This is the air pressure when the blow out valve is energized. It can be set by manually actuating the valve and subsequently adjusting the regulator. If this pressure is set too high (above 30 PSI), the 202 nozzles will be opened, and the spray cycle will continue.
F	Pump Inlet Pressure	50 PSI Minimum. Increase pressure to increase liquid volume. This will increase pump flow and outlet pressure. Liquid pressure at the 202 atomizers must be above the Spray Pressure (B) in order to avoid backpressure inconsistencies.
G	Pump Shutoff	Open during normal operation. Allows for quick shut off of reservoir pump in the event of an emergency involving a leaking valve, hose, or strainer.
H	Fluid Recirculation Ball Valve	<10% Open (for 30 cycles per minute). This valve adjusts the recirculation flow back to the reservoir and pressure to the nozzle. As this valve is opened, the flow rate to the reservoir increases, while the liquid pressure to the nozzle is reduced.
I	202 Dial Setting (Does not apply to 204 Nozzle)	4 CCW Turns from Off. As used in this equipment, this is merely a macro adjustment. Liquid is shut off when the knob is adjusted tight in the clockwise direction; flow is increased by then rotating in a counterclockwise direction.
J	Needle Valve Setting	3 CCW Turns from Off. This adjustment is used to set an exacting liquid flow. Liquid is shut off when the knob is adjusted tight in the clockwise direction; flow is increased by then rotating in a counterclockwise direction. This adjustment is truly the liquid volume adjustment. Once set, use pump pressure or spray time to adjust liquid flow volume per spray cycle.
K	Exit Gauge	Visual inspection during operation, should read over 40 psi during liquid on, and should drop to 10 psi or less during blow-out.

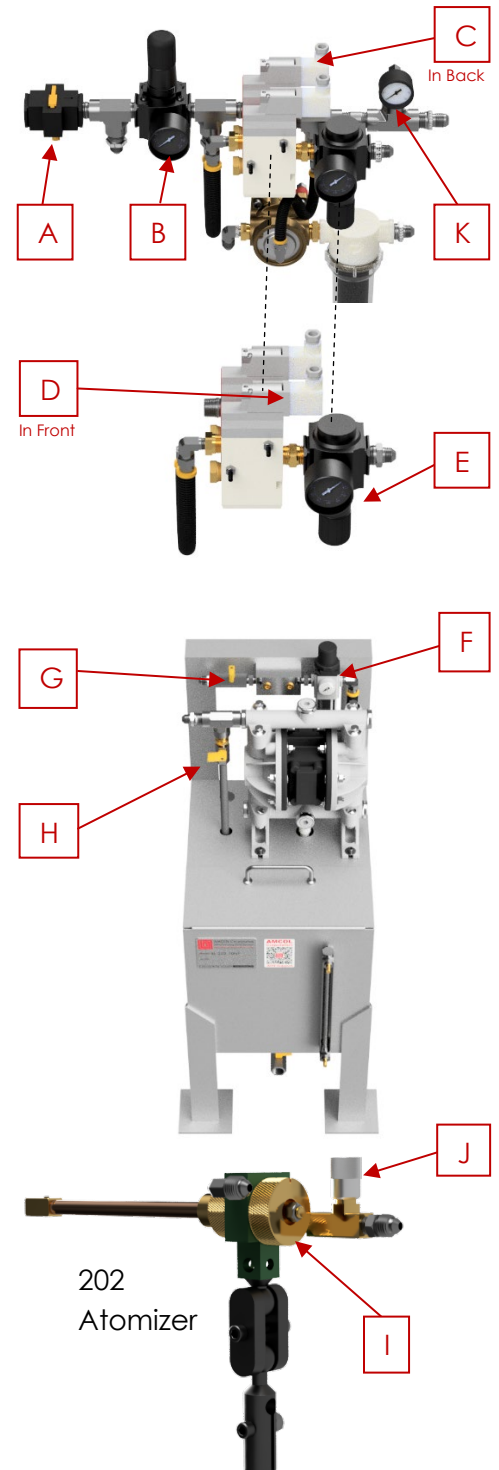

4a. Recommended Settings for **3049B1 with 204**

Item ID	Description	Recommended Setting (and Explanation)
A	System Shutoff	Open during normal operation – Close to perform repairs. Has lock and tag eyelet.
B	Spray Pressure Regulator	40 PSI. This is the valve package inlet pressure. It can be set with no valves energized. This air pressure determines spray pressure when the liquid and air are both energized.
C	Spray Valve (back valve)	Energize for the first 0.5 seconds and then deenergize. Actuating this valve opens liquid at the valve package (liquid safety switch) and air and liquid at the atomizing nozzle.
D	Blow Out Valve (front valve)	0.5 seconds after deenergizing the spray valve, energize the blow out valve for 2.5 seconds or more. This valve is used to clear the liquid from the spray tubes and will only supply air to the nozzle.
E	Blow Out Pressure Regulator	20 PSI. This is the air pressure when the blow out valve is energized. It can be set by manually actuating the valve and subsequently adjusting the regulator. If this pressure is set too high (above 30 PSI), the 204 nozzles will be opened, and the spray cycle will continue.
F	Pump Inlet Pressure	50 PSI Minimum. Increase pressure to increase liquid volume. This will increase pump flow and outlet pressure. Liquid pressure at the 204 atomizers must be above the Spray Pressure (B) in order to avoid backpressure inconsistencies.
G	Pump Shutoff	Open during normal operation. Allows for quick shut off of reservoir pump in the event of an emergency involving a leaking valve, hose, or strainer.
H	Fluid Recirculation Ball Valve	<10% Open (for 30 cycles per minute). This valve adjusts the recirculation flow back to the reservoir and pressure to the nozzle. As this valve is opened, the flow rate to the reservoir increases, while the liquid pressure to the nozzle is reduced.
I	204 Knob Setting (Does not apply to 202 Nozzle)	9 clicks from Off. This adjustment is used to set an exacting liquid flow. Liquid is shut off when the knob is adjusted tight in the clockwise direction; flow is increased by then rotating in a counterclockwise direction. This adjustment is truly the liquid volume adjustment. Once set, use pump pressure or spray time to adjust liquid flow volume per spray cycle.
J	Exit Gauge	Visual inspection during operation, should read 35-40 psi.

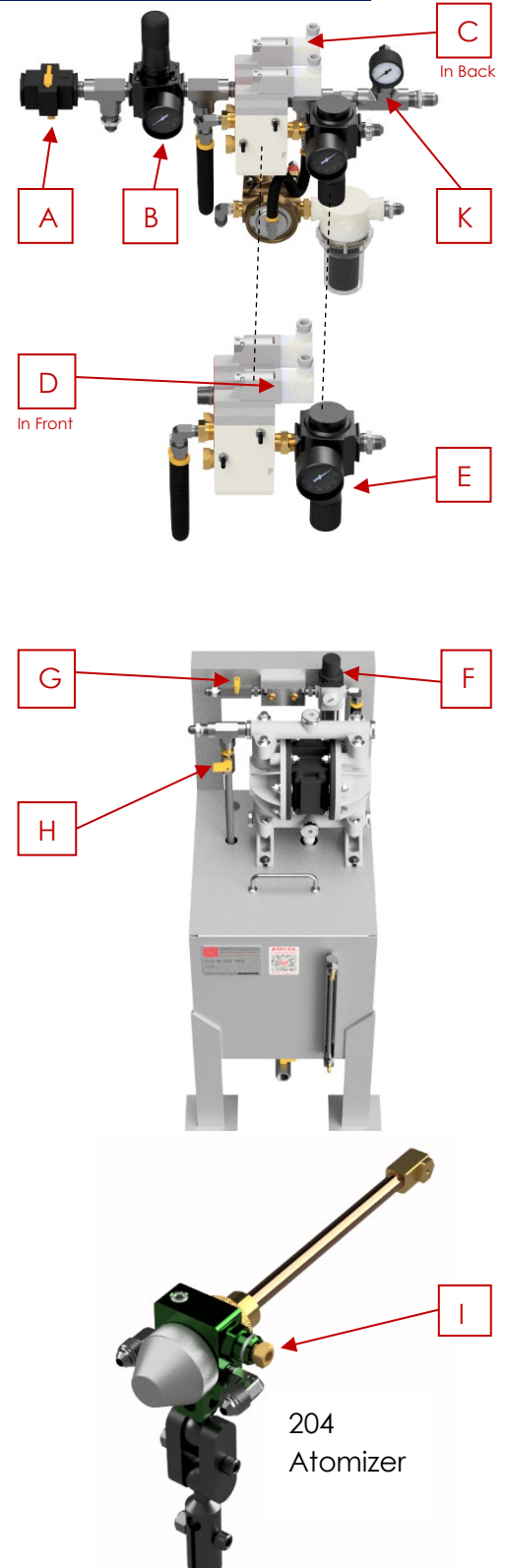

5. Operation

Prior to Getting Started

- Be sure that all hoses are connected to the appropriate fittings and tightly secured.
- Put enough fluid in the reservoir to allow the system to operate.
- Securely connect an air source to the main air inlet and energize the air line connected to the system.

Operating the System Shutoff Valve

- Observe Spray Pressure [B] is 0 psi when the System Shutoff valve [A] is closed.
- Open System Shutoff valve [A] and set the Spray Pressure Regulator [B] to 40 psi.

Setting & Operating the Reservoir Pump

- Open the Pump Shutoff valve [G] and set Pump Inlet Pressure [F] to at least 50 psi.
- Open the Fluid Recirculation Valve [H] so that the pump cycles approximately once every two seconds.

Setting the 202 Nozzle (Old Versions)

- Confirm that the 202 Dial [I] is set to four rotations from fully closed.
- Confirm that the Needle Valve [J] on the 202 nozzle is set to 3 rotations from fully closed and then tighten the set screw.

Setting the 204 Nozzle (New Versions)

- Confirm that the Adjustment Knob [I] on the 204 nozzle is set to 9 clicks or 1 rotation from fully closed.

Setting Nozzle Blow Out Pressure

- Manually actuate the air Blow Out Valve (front valve) [D] and set the Blow Out Pressure Regulator [E] to 20 psi.

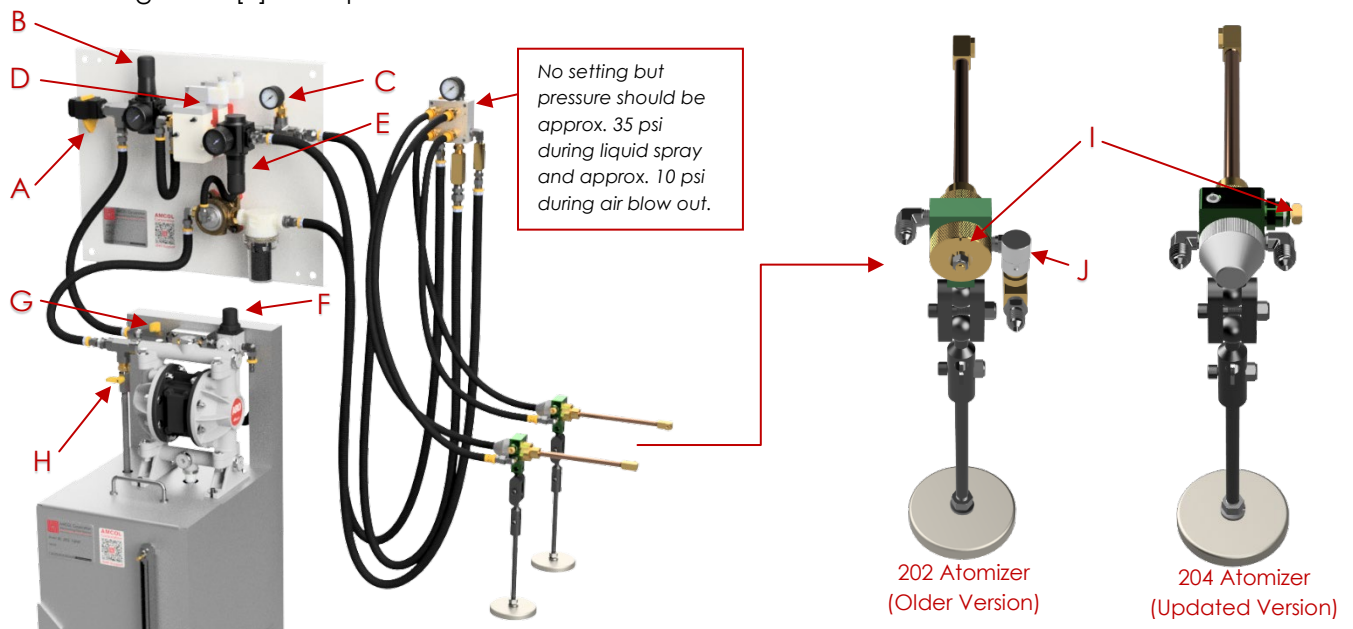

Cycle Timing

Cycle Timing (Manual)

- The figure below demonstrates the timing sequence used for the manual and automatic system cycling.
- Be sure to include at least 0.5 second delay between the liquid and blowout cycle to ensure that the 202/204 nozzle properly closes and liquid does not continue to be output during the blow out cycle. Additionally, if the delay is longer than 1 second, dripping will occur before the blow out cycle is initiated.



Manual Actuation

- Observe pressure changes and the 202 piston [I] open (does not apply for 204 nozzle) with Spray Valve (back valve) [C] actuation.
- Observe Blow Out Pressure [E] changes with actuation of the Blow Out Valve (front valve) [D].
- Due to the length timing gap between liquid and air actuation, expect some dripping to occur at the tips during manual operation.

Cycle Timing (Automatic)

- There is no dripping during automatic cycling.
- To operate the system automatically, desired settings should be programmed into the machine PLC. Start by operating the system with the timing sequence shown below. Spray and blow out timing can be adjusted to optimize the system for the system for your operation.



6. BL 463 2S EJECTEZE

BL 463 2S EJECTEZE is a water-dilutable lubricating fluid. It is designed to cool as the water evaporates, then travels by capillary action to completely coat the tool steel with a liquid lubricant, leaving only a light oily residue. There is no smoke or flame and no known effects on the extrudate. **BL 463 2S EJECTEZE** in combination with the AMCOL 3049B Spray System will reduce aluminum build-up and sticking as well as maximize shear life and cut quality. **BL 463 2S EJECTEZE** is available for purchase in 5 gallon pails or 55 gallon drums.



PA201 Refractometer

The PA201 Refractometer, manufactured by Misco, is a handheld testing instrument used to check and monitor dilution ratios of liquid concentrates that are mixed with water. It is operated by placing a drop or two of fluid in the titanium bowl, then pressing the activation button. A microprocessor will then deliver a nearly instantaneous digital readout on an LCD display.



This numerical reading can be correlated to a specific dilution for a given product using a cross reference chart or logarithmic formula.

Calibration is automatic and does not require the use of special calibration solutions or tools. See the Misco PA201 Refractometer reference manual for additional information.

The Misco PA201 Refractometer is based on the Brix scale reading system. There are many different types and makes of Refractometers that can be used as a substitute. Be sure that whatever system is used is reliable and easy to operate.

7. System Troubleshooting

Check in order as listed.

No Liquid

- Reservoir is empty or low. Double diaphragm pump will be cycling at a very high rate. Fill.
- Air pump malfunctioning. Repair or replace.
- Air pressure to nozzle exceeds liquid pressure. Refer to recommended settings.
- Air pressure too low and cannot actuate safety switch (40 psi min.). Refer to recommended settings.
- Atomizer or safety switch stuck closed. Repair or replace.
- Fluid return ball valve on reservoir not restricted. Refer to recommended settings.
- Air pockets in liquid hose. Manually actuate until volume is consistent.

Too Much Liquid

- Liquid flow misadjusted (see System Settings).
- Spray valve open too long.
- Pump pressure on reservoir too high.

Too Little or Inconsistent Liquid



- Spray extension is clogged or kinked.
- Opposite of Too Much Liquid, as referenced above.
- Nozzle or liquid strainer clogged. Clean.
- Air pockets in liquid hose. Manually actuate until volume is consistent.

Fluid Runs on After Spray

- Spray Valve (back valve) [C] has not been properly deenergized prior to blow out.
- Spray cycle is too long. Refer to recommended settings.
- 202/204 Nozzle is malfunctioning. Repair or replace.
- Safety switch malfunctioning. Repair or replace
- Spray Valve (back valve) [C] is not closing properly. Clean, grease, and reassemble.

8. MRO Inventory

Recommended Spares

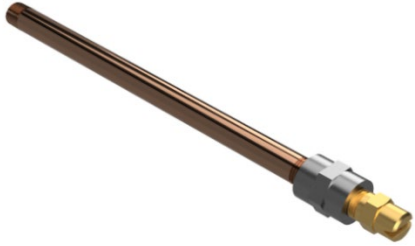
Reference	Image	Description	Part Number	QTY
A		204 Spray Nozzle (Updated version)	204-014-AC	2 ea.
B		Rebuild Kit for 204 (Updated Version)	A4008279	2 ea.
C		90 Degree Spray Nozzle with 6" Pipe (included with 3049B2-RK)	13-90DSN-6	2 ea.
D		Spray Nozzle with 6" Pipe (Included with 3049B2-06F-RK)	13-DSN-6	2 ea.

E		6" Copper Clad Nozzle Assembly with 135° Bend	3049-6CC-135	2 ea.
F		Rebuild Kit for 66605J-34B Diaphragm Pump	637140-4B	1 ea.
G		Check Balls, 3/4" PTFE, for 66605J-34B DP	93100-4	4 ea.
H		Clear Bowl for 1/2 in-line strainer with Gasket	9875K11-AC	2 ea.
I		80 Mesh Replacement Screen for T-Strainer (SS)	9875K82	1 ea.
J		P/H Fire Res. Hose (1/4")	821FR-4-BLU	30 ft.
K		P/H Fire Res. Hose (3/8")	821FR-6-BLK	30 ft.

L		P/H Fire Res. Hose (1/2")	821FR-8-BLK	15 ft.
M		140 psi Pressure Gauge (for manifold)	18-013-212	1 ea.
N		160 psi Pressure Gauge (for regulators)	18-013-209	1 ea.
O		1/2" Polypropylene Pump with PTFE Check Balls	66605J-34B-AC	1 ea.
P		Liquid Safety Switch, Pilot Air Control, Humphrey Valve 2-Way	01285-HMY	1 ea.
Q		3 Way Poppet Valve with Coil	110vAC VP742-3DZ1-04TA -or- 24vDC VP742-5DZ1-04TA	2 ea.

Repair Kits

- 3049B2-RK for systems that use the 6" pipe extension and 90-degree spray nozzle.
- 3049B2-06F-RK for systems that use the 6" pipe extension and straight fan spray nozzle.
- 3049B2-135-RK for systems that use the 6" Copper Clad Nozzle Assembly with 135° Bend.

Ref ID	Part Number	Description	QTY	3049B2-RK	3049B2-06F-RK	3049B2-135-RK
A	204-014-AC	204 Spray Nozzle (Updated version)	2 ea.	●	●	●
B	A4008279	Rebuild Kit for 204 (Updated Version)	2 ea.	●	●	●
C	13-90DSN-6	90 Degree Spray Nozzle with 6" Pipe	2 ea.	●		
D	13-DSN-6	Spray Nozzle with 6" Pipe	2 ea.		●	
E	3049-6CC-135	6" Copper Clad Nozzle Assembly with 135° Bend	2 ea.			●
F	637140-4B	Rebuild Kit for 66605J- 34B Diaphragm Pump	1 ea.	●	●	●
G	93100-4	Check Balls, 3/4" PTFE, for 66605J-34B DP	4 ea.	●	●	●
H	9875K11-AC	Clear Bowl for 1/2 in-line strainer with Gasket	2 ea.	●	●	●
I	9875K82	80 Mesh Replacement Screen for T-Strainer (SS)	1 ea.	●	●	●

9. Maintenance

Preventative and Predictive Maintenance

Daily

- Observe fluid level and fill as necessary.
- Observe system settings for Reservoir and Valve Package and adjust as necessary.
- Observe spray quality and quantity and adjust as necessary.
- Check fluid dilution using Misco PA201 Digital Refractometer (information regarding the Misco PA201 can be found below). Correct dilution as necessary. A dilution chart can be found In the Technical Bulletin for BL 463 2S EJECTEZE.

Quarterly

- Replace 80 Mesh Screen, Clear Bowl, and Gasket.
- Replace Check Balls for Diaphragm Pump (4 ea.).

Biannually

- Completely empty reservoir. Wash with water. Refill.
- Disassemble and rebuild 202/204 nozzles or completely replace.

Yearly

- All biannual maintenance.
- Replace all liquid and air hoses.
- Disassemble and inspect/repair or replace 3-way air operated solenoid valves on Valve Package.
- Rebuild or replace Rebuild Kit for 66605J-34B Diaphragm Pump (use PTFE Balls and Santoprene diaphragms).

Retrofitting the 01285-HMY Safety Switch

Older systems that still have old ASCO or Parker Liquid Safety Switches can be easily retrofitted to the new, more reliable Humphrey Liquid Safety Switch.

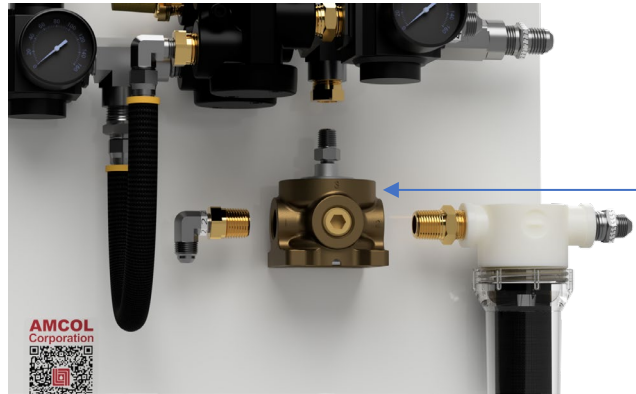

1. Lockout and Tag the system.
2. Remove the old ASCO or Parker Liquid Safety Switch from the valve pack, leaving the brass reducer still attached to the tee fitting. The valve pack assembly will likely have to be removed from the mounting plate.
3. Disconnect the strainer and elbow assemblies from the old safety switch.
4. Attach the strainer and elbow assemblies to the new safety switch as shown above.
5. Reinstall the new Humphrey safety switch.

You are ready to operate!

Additionally, there is a retrofit kit (**Part #: 01285-HMY-RETRO**) available to mount the safety valve to the plate as seen below:

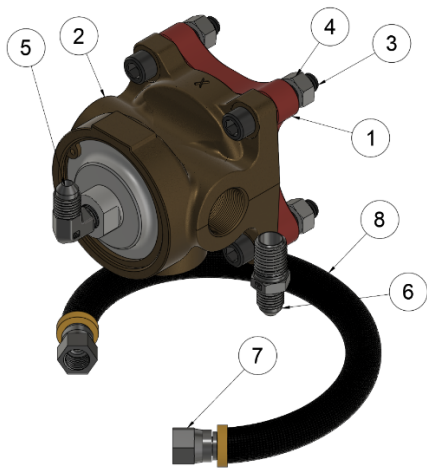
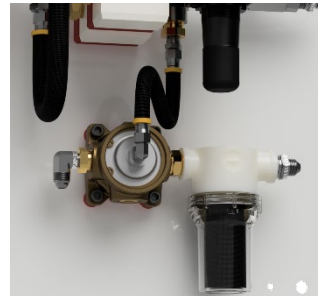

PARTS LIST		
ITEM	QTY	PART NUMBER
1	1	01285-HMY-SPACER
2	1	01285-HMY
3	4	31C150SHC
4	4	31CNNEZ
5	1	4-37-6
6	1	4-4-37-2
7	2	30682-4-4
8	1	821FR-4-BLK

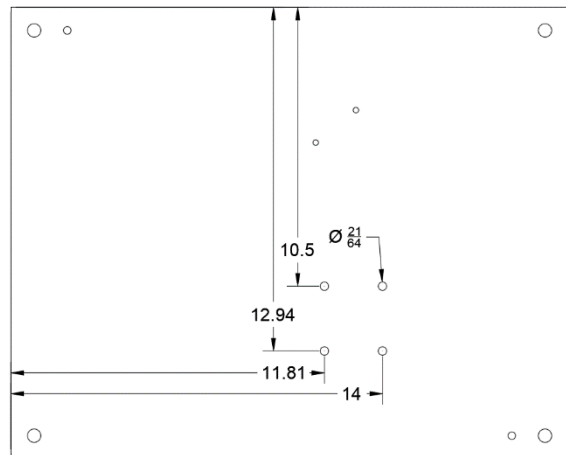

Simply follow the steps above and drill mounting holes for the valve according to the drawing.

10. Schematics

System Schematic

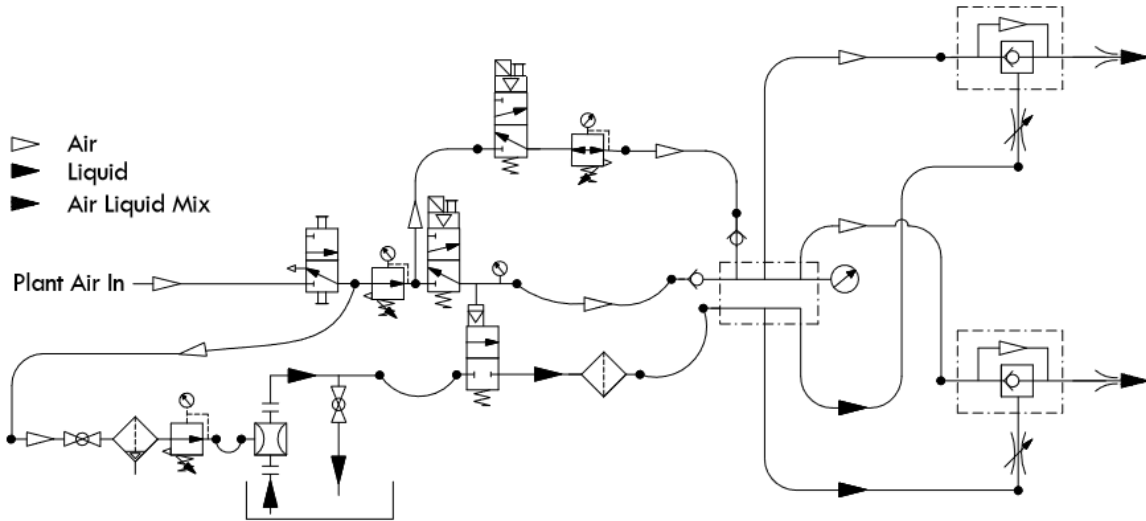

202 Spray Nozzle - Discontinued

202-MMB-M

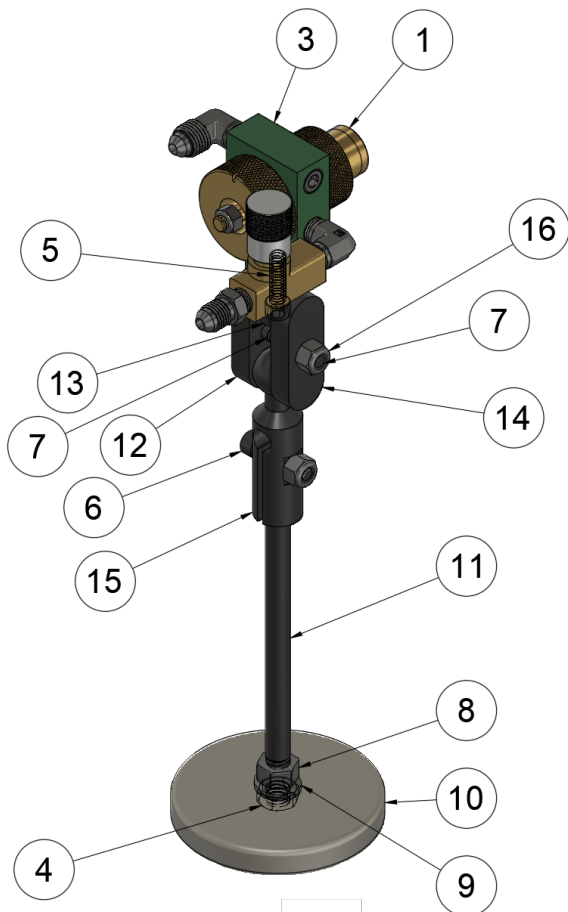

202 Internal View

PARTS LIST		
ITEM	QTY	PART NUMBER
1	1	02426-1
2	1	02426-4
3	1	202-018F
4	1	37CFJN
5	1	25C87SHC
6	1	25F100SHC
7	1	25F150SHC
8	1	37CFHN
9	1	37NMLW
10	1	5419-88-AC
11	1	6000-MMB-ER6
12	1	69375
13	1	69750
14	1	79375
15	1	79750
16	2	25FCNNEZ

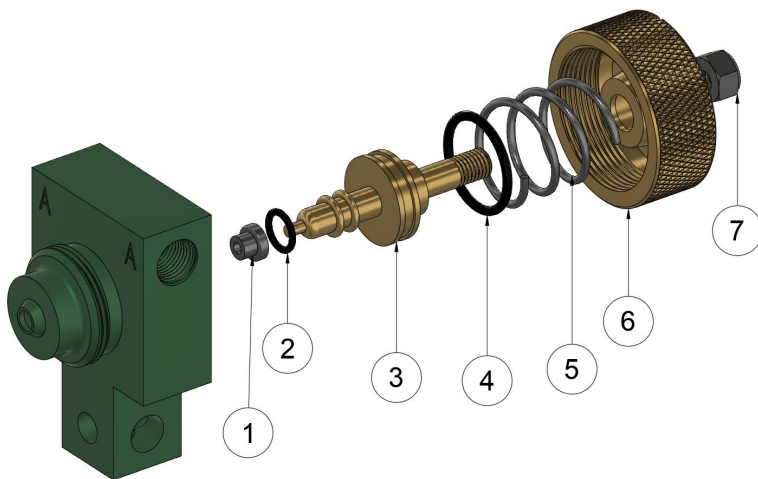

PARTS LIST		
ITEM	QTY	PART NUMBER
1	1	01667-E
2	1	01004-E
3	1	04366-C
4	1	01340-E
5	1	04368-D
6	1	04367-C
7	1	04373

204 Spray Nozzle - Updated

204-MMB-M

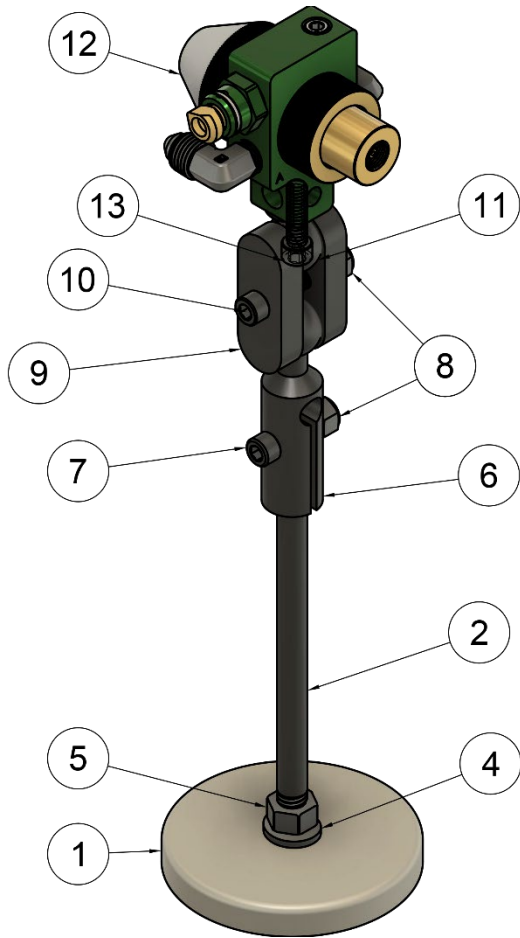

PARTS LIST		
ITEM	QTY	PART NUMBER
1	1	5419-88-AC
2	1	6000-MMB-ER6
3	1	37CFJN
4	1	37NMLW
5	1	37CFHN
6	1	79750
7	1	25F100SHC
8	2	25FCNNEZ
9	2	69375
10	1	25F150SHC
11	1	69750
12	1	204-014F
13	1	25C87SHC

204 Internal View

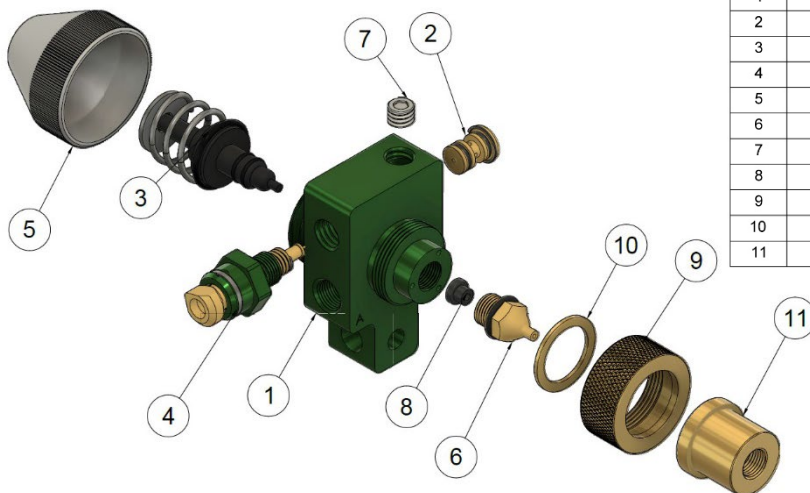

PARTS LIST			
ITEM	QTY	PART NUMBER	DESCRIPTION
1	1	A3031810	BODY
2	1	A4005667	0X4 SERIES NOZZLE METERING SEAT
3	1	A4005642	PISTON ASSEMBLY
4	1	A4005681	0-1.0 GPM ADJUSTABLE METER
5	1	A3027000	POPPET CAP
6	1	A3031782	LIQUID INJECTOR TIP
7	1	01048-D	PIPE PLUG 1/16" NPT SS
8	1	A3031488	NOZZLE SEAT VITON
9	1	01019-C	SPRAY HEAD LOCK RING FOR 202
10	1	02426-4	SEAT SPACER
11	1	02426-1	TIP NOZZLE FOR EXTENDED SPRAY

Reservoir BL-202-10NP

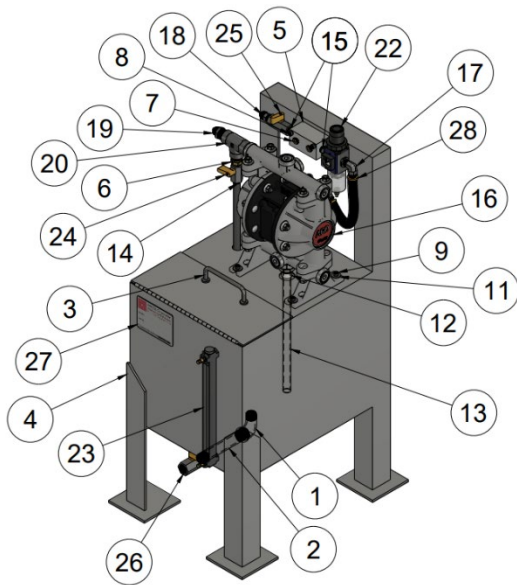

PARTS LIST			PARTS LIST		
ITEM	QTY	PART NUMBER	ITEM	QTY	PART NUMBER
1	1	001543	15	2	4-PC-11
2	1	015112-AC2	16	1	66605J-34B-AC
3	1	11665A21	17	1	6-37-6
4	1	2000-R10-TANK-AC	18	1	6-37-2
5	1	201-1	19	1	6-8-37-2
6	1	209P-8-4	20	1	8-PC-25
7	2	219P-4	21	1	9563K46
8	2	25C225SHC	22	1	B07-202-M1KA
9	4	25C87SHC	23	1	B-1579-1
10	6	25CNNEZ	24	1	MV608-4
11	4	25NUFW	25	1	MV609-4
12	1	43104	26	1	MV609-8
13	1	44875-AC1	27	1	2-SEP
14	1	48855K41-AC1	28	1	FR6A-0.75

Valve Package MVO-101BR2

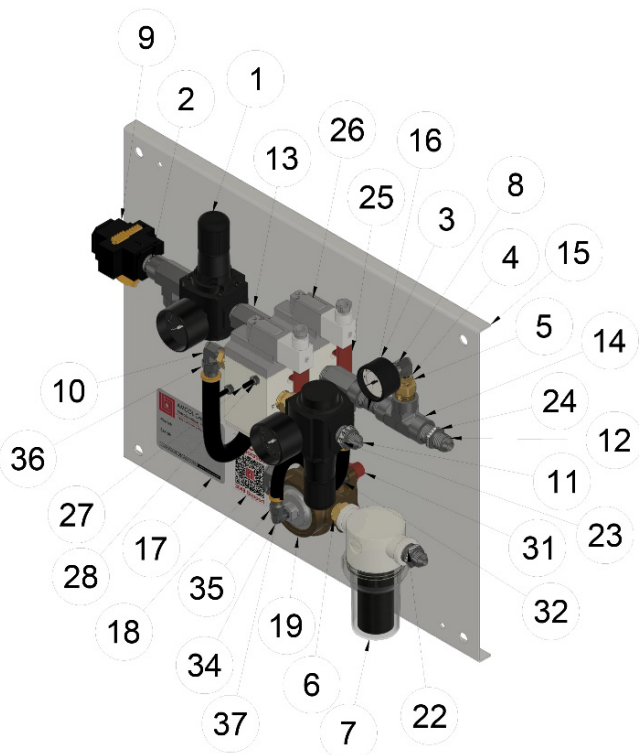

PARTS LIST			PARTS LIST		
ITEM	QTY	PART NUMBER	ITEM	QTY	PART NUMBER
25	2	VP742-SPACER	1	2	01140
26	2	VP742-3DZ1-04TA	2	2	005297
27	2	91251A907	3	1	18-013-212
28	2	10FNMMZ	4	1	209P-4-2
29	2	9833K11	5	4	209P-8-4
30	1	4-4-37-2	6	2	216P-8
31	1	01285-HMY-SPACER	7	1	2P132
32	4	31C150SHC	8	1	2-PC-18
33	4	31CNNEZ	9	1	48115K85
34	1	4-37-6	10	2	6-37-6
35	2	30682-4-4	11	4	6-8-37-2
36	1	SP-HOS	12	1	8-8-37-2
37	1	821FR-4-BLK	13	3	8-PC-24
			14	1	8-PC-25
			15	1	HOA-24P20-AC2
			16	1	005299
			17	1	2-SEP
			18	1	LABEL-3049 SUPPORT
			19	1	01285-HMY
			20	1	MMMSDR1
			21	1	MMMSDR2
			22	1	MMMSDR5 V1
			23	1	MMMSDR4 V5
			24	1	MMMSDR7 V1

Air/Liquid Manifold 201-1LAR

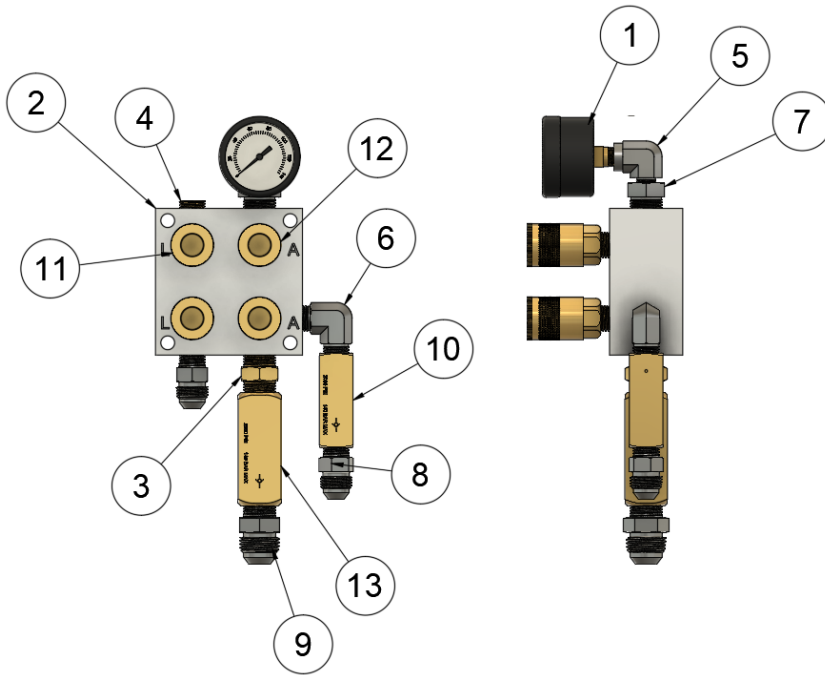

PARTS LIST		
ITEM	QTY	PART NUMBER
1	1	18-013-212
2	1	201-2
3	1	216P-6
4	1	219P-4
5	1	2-PC-18
6	1	4-PC-17
7	1	6-2-HB
8	2	6-37-2
9	1	8-37-2
10	1	JC-2
11	2	B-52
12	2	B-22
13	1	JC-3



AMCOL Corporation

21435 Dequindre, Hazel Park, MI 48030 | 248-414-5700 | fax: 248-414-7489 | www.amcolcorp.com