

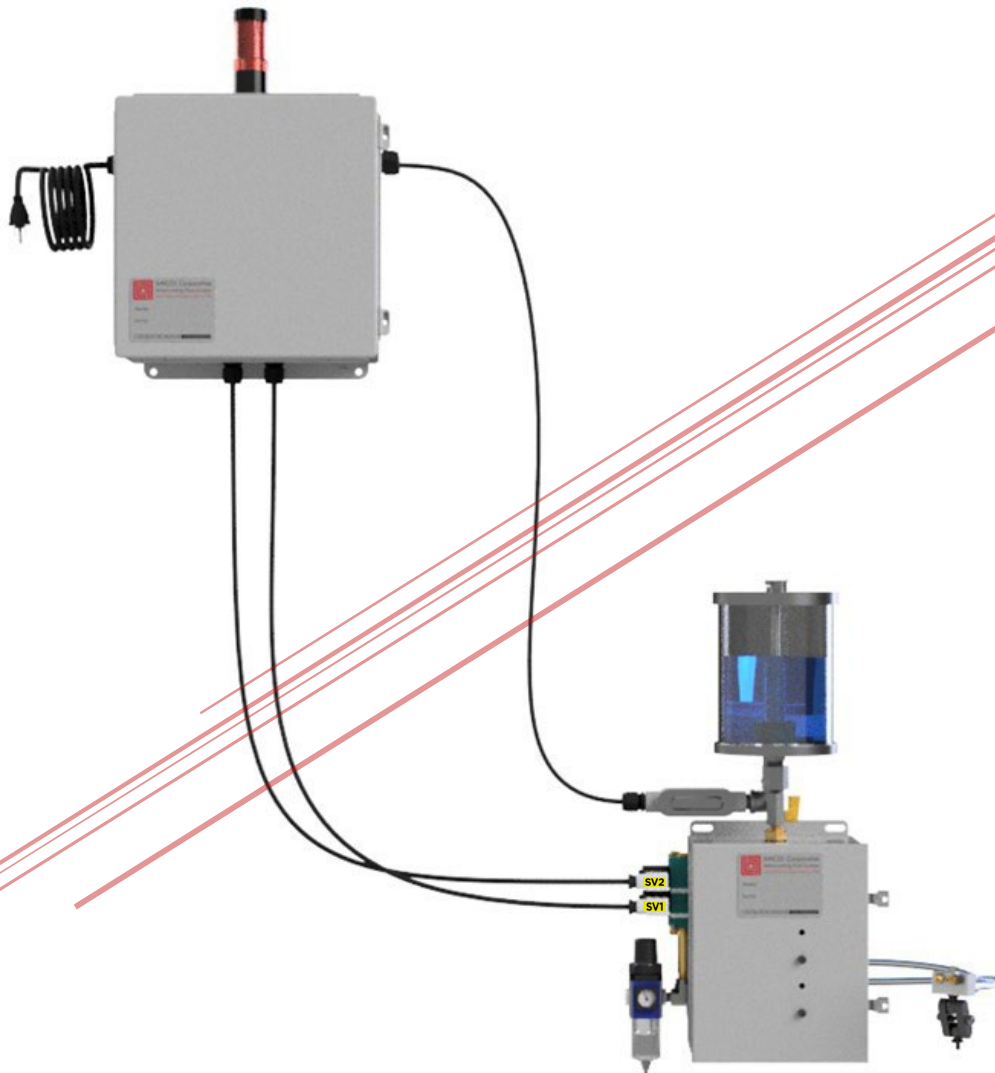

AMCOL CORPORATION

ELECTRONIC TIMING CONTROLLER FOR FORMING AND FABRICATING 6000E SYSTEMS

TECHNICAL DESCRIPTION AND OPERATOR'S MANUAL



What is Electronic Control of Injection Pulse Rate?



Figure 1

A Quick Solution to Upgrade to Electronic Pulse Rate Control

The **AMCOL 6000E Precision Applicator** is equipped with a two-solenoid valve configuration where **Dispersing Air Pressure is controlled separately from the Injection Pulse Rate** (system shown in Figure 1). This configuration is an alternative to the better-known single solenoid valve systems where injection rate is controlled with an integral air timer (also known as a Pulse Frequency Generator).

The concept and option for electronic control of injection rate is not new and is quickly gaining popularity. By replacing the air operated timer with electronic control of injection rate, the result is precise, repeatable, and adjustable lubricant output volumes.

In many situations, the electronic control of pulse rate comes from the machine PLC. Programming a PLC and installing additional hard wiring for the two-solenoid configuration is not always easy. **AMCOL has created a quick simple solution to convert your one electric air solenoid output to a two-valve output.**

The 6000-ETC-FF Electronic Timing Controller for Forming and Fabricating

The 6000-ETC-FF is a self-contained PLC that is preprogrammed to interface with your machine **to convert your one-solenoid valve output to be two-solenoid valve output.**

The first output will control the Dispersing Air Solenoid Valve (SV1) and it will be on during the complete spray cycle that is determined by the number of injections and cycle time. The second output will control Injection Pulse Rate Solenoid Valve (SV2) during the spray cycle where the cycle rate will equal T2. (See figure 2)

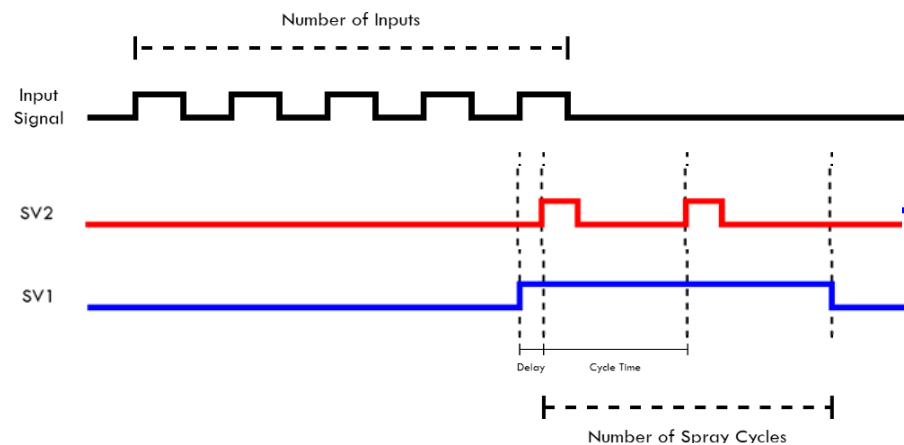

Figure 2

The 6000-ETC-FF gives you the ability to change the number of injections and the pump cycle time quickly and accurately after the desired number of inputs at the push of a button.

More About the 6000-ETC-FF

The 6000-ETC-FF is designed to convert your 110 VAC, 24 VDC machine, or PLC output (quickly and easily) to a dual solenoid control box with electronic adjustable injection rate timing. Using this controller, Injection Pulse Rate will not be controlled with a pneumatic timer, but rather a variable electronic output that can be quickly and easily moved up and down.

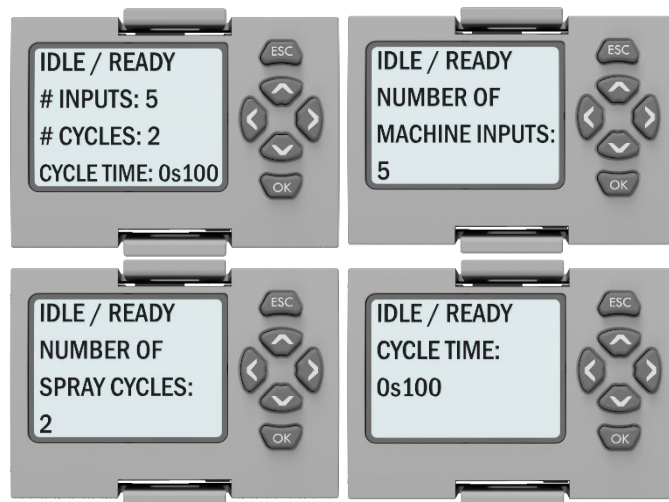

Figure 3

A clear viewing screen shows the spray cycle settings. Figure 3 shows the main screen (top left) that displays the current system settings. Additional screens allow for modification of these settings.

To incorporate this technology, an AMCOL 6000E Precision Applicator is required. The two-solenoid control package is available on new AMCOL 6000 Series Spray equipment and can also be retrofitted to older model single air source systems.

The 6000-ETC Electronic Timing Controller includes:

- Preprogrammed PLC.
- 6' grounded power cord with plug.
- Open cable gland to insert your existing power output and make connection.
- NEMA 12/13 sealed steel electrical enclosure.
- Solenoid outputs prewired for quick connection to MAC 100 Series valves.

There are four available control packages:

1. 6000-ETC-FF-24 – Your control output is 24VDC.
2. 6000-ETC-FF-110 – Your control output is 110 VAC.
3. 6000-ETC-FF-24-LLI – Your control output is 24VDC, system has optional low-level light.
4. 6000-ETC-FF-110-LLI – Your control output is 110 VAC, system has optional low-level light.

Connecting the 6000-ETC-FF to Your Machine

Integrating the 6000-ETC Controller is simple and easy to do by following these simple instructions:

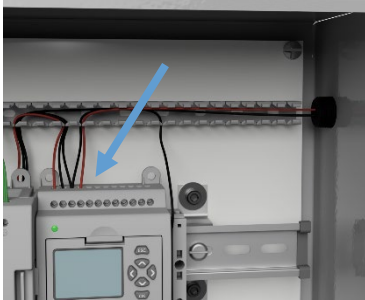

Figure 4

1. Mount the control box in a position where it is easy to access, protected from damage, and a short distance from your AMCOL 6000 Series Precision Applicator. Output wires from this controller to the spray system are standard at two feet. To extend these wires, they should be properly connected to a junction box and extended using conduit.
2. Insert your machine input through the available cable gland and connect to the controller as shown in *Figure 4*.

3. Connect the prewired solenoid caps with lights to the solenoid valves. The leftmost cable should connect to the Dispersing Air Solenoid Valve (SV1), and the rightmost cable should connect to the Injection Pulse Rate Solenoid Valve (SV2).
4. Plug in power cord.

You are now ready to operate.

Operating the 6000-ETC-FF

The 6000-ETC-FF has two operating modes:

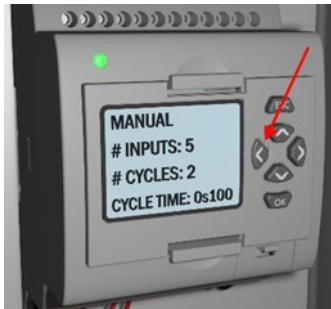

Figure 5

1. **Automatic** – This will operate only when your machine output power is on. It is designed to automatically turn on per the settings and begin the spray cycle when your machine output is energized. Automatic mode is the standard of operation for 6000-ETCs.
2. **Manual** – This will turn the spray system on for one full cycle and will only operate when the left arrow (<) is pressed (see *Figure 5*). Manual mode should be used for setup, testing, and troubleshooting.

Settings can be modified by pressing the right arrow (>) to move to the desired screen. The individual setting can be increased using the up arrow (^) or decreased using the down arrow (v) (see *Figure 6*). Input and output settings are increased and decreased by 1, and timing settings are increased or decreased by 100ms per press.



Figure 6

Low-Level Indicator- Accessory



As an optional addition, 6000-ETCs can be ordered with a low-level indicator light that interfaces with a ½ Gallon Reservoir on the 6000E Spray System. This indicator light will flash when the reservoir is low, ensuring your system never runs dry. Installation is simple—connect the cable gland and the prewired cable from the ETC to your existing low-level switch on the reservoir. This option requires that your reservoir is equipped with a low-level switch.

Can I Retrofit an Existing AMCOL 6000 Series Spray System?

Absolutely! There are two options to upgrade to electronic control:

1. **The simplest solution is to replace your complete control box.** You can still reconnect your existing reservoir, liquid transport lines, and spray assemblies.
2. **Retrofit your existing control box** from a one solenoid input to the dual solenoid version for electronic control. There is a retrofit kit available including a template used to modify the steel enclosure that houses the T60A Injectors and pneumatic controls and connections.

Please remember this controller is only applicable for use with an AMCOL 6000 Series Precision Spray Applicator with the two-solenoid control package.

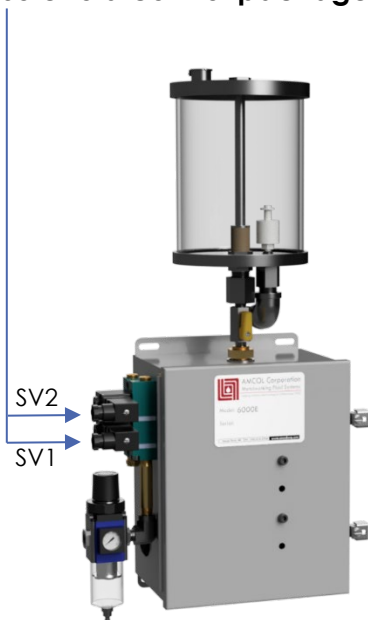

Wiring Diagrams

6000-ETC-24

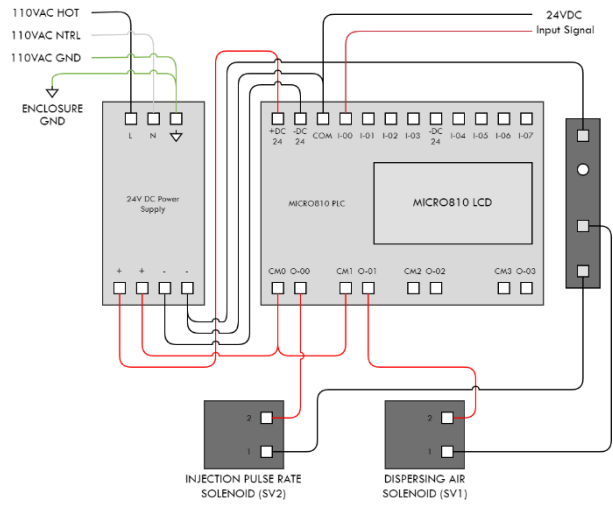

6000-ETC-110

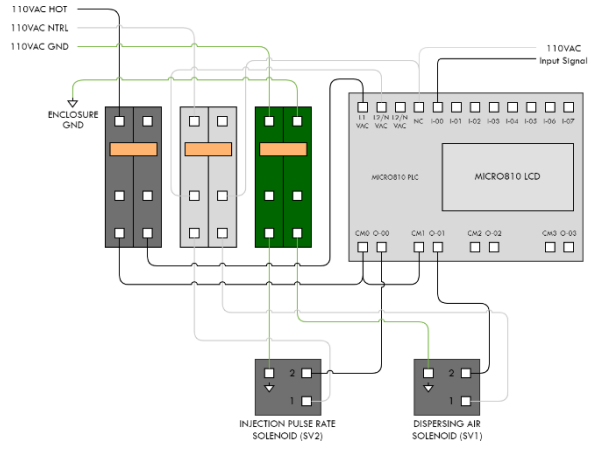

6000-ETC-24-LLI

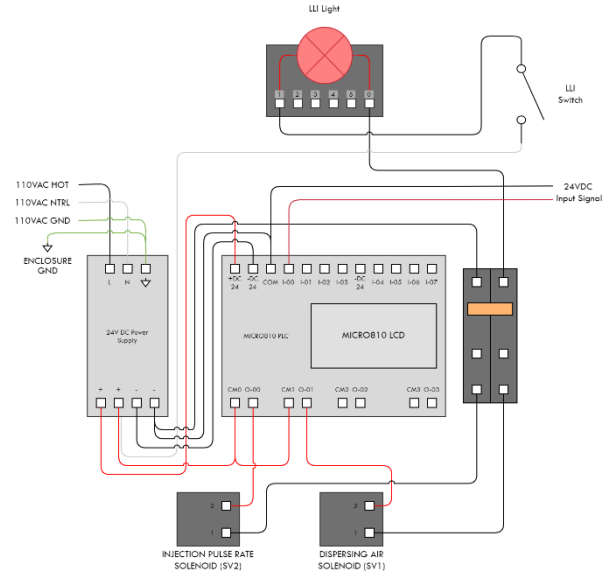

6000-ETC-110-LLI

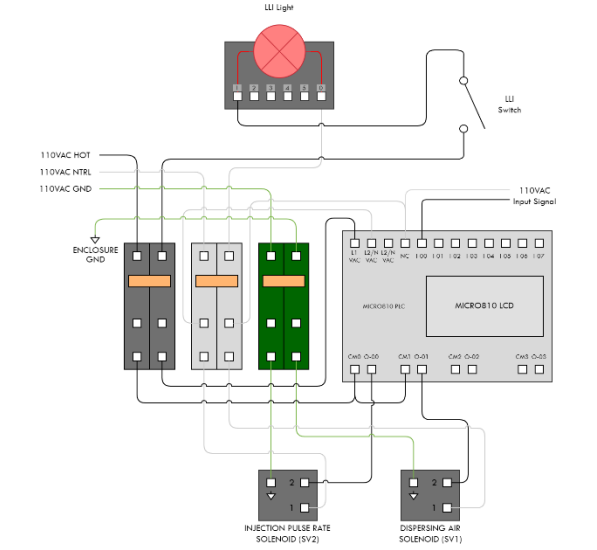

AMCOL Corporation

21435 Dequindre, Hazel Park, MI 48030 248-414-5700 fax: 248-414-7489 www.amcolcorp.com