



AMCOL CORPORATION
6000-ETC ELECTRONIC
TIMING CONTROLLER
Operator's Manual



Contents

1 Introduction	2
2 Included Components	3
3 Assembly and Installation.....	3
PRIOR TO GETTING STARTED	4
Installation	4
4 Recommended Settings	5
5 Operation	6
Proper Operation.....	6
6 System Troubleshooting and Maintenance	8
7 Schematics	9



AMCOL Corporation

21435 Dequindre, Hazel Park, MI 48030	248-414-5700	fax: 248-414-7489	www.amcolcorp.com
---------------------------------------	--------------	-------------------	--

1 Introduction



The AMCOL 6000E Series Precision Applicator is available with a two-solenoid valve configuration where Dispersing Air Pressure is controlled separately from the Injection Pulse Rate. This configuration is an alternative to the more commonly used single solenoid valve systems where injection rate is controlled with an integral air timer (also known as a Pulse Frequency Generator).

The concept and option for electronic control of injection rate is not new, but is quickly gaining popularity. By replacing the air operated timer with electronic control of injection rate, the result is precise, repeatable, and easily adjustable lubricant output volumes.

In many situations, the electronic control of pulse rate comes from the machine PLC. Reprogramming a PLC and installing additional hard wiring for the two-solenoid configuration is not always easy or efficient. To solve this problem, AMCOL has created a simple package to control a dual solenoid 6000E system with a single PLC output.

2 Included Components

Each 6000-ETC comes standard with the following components:

1. Preprogrammed Allen Bradley PLC
2. 6' grounded power cord with plug
3. Open cable gland to insert the machine PLC control output
4. NEMA 12/13 sealed steel electrical enclosure
5. Solenoid caps prewired for quick connection to MAC 100 Series valves

As an optional addition:

6. Light for connection with a low-level indicator. (6000E must have LLI option)
7. Sealed conduit connection for reservoir with LLI.

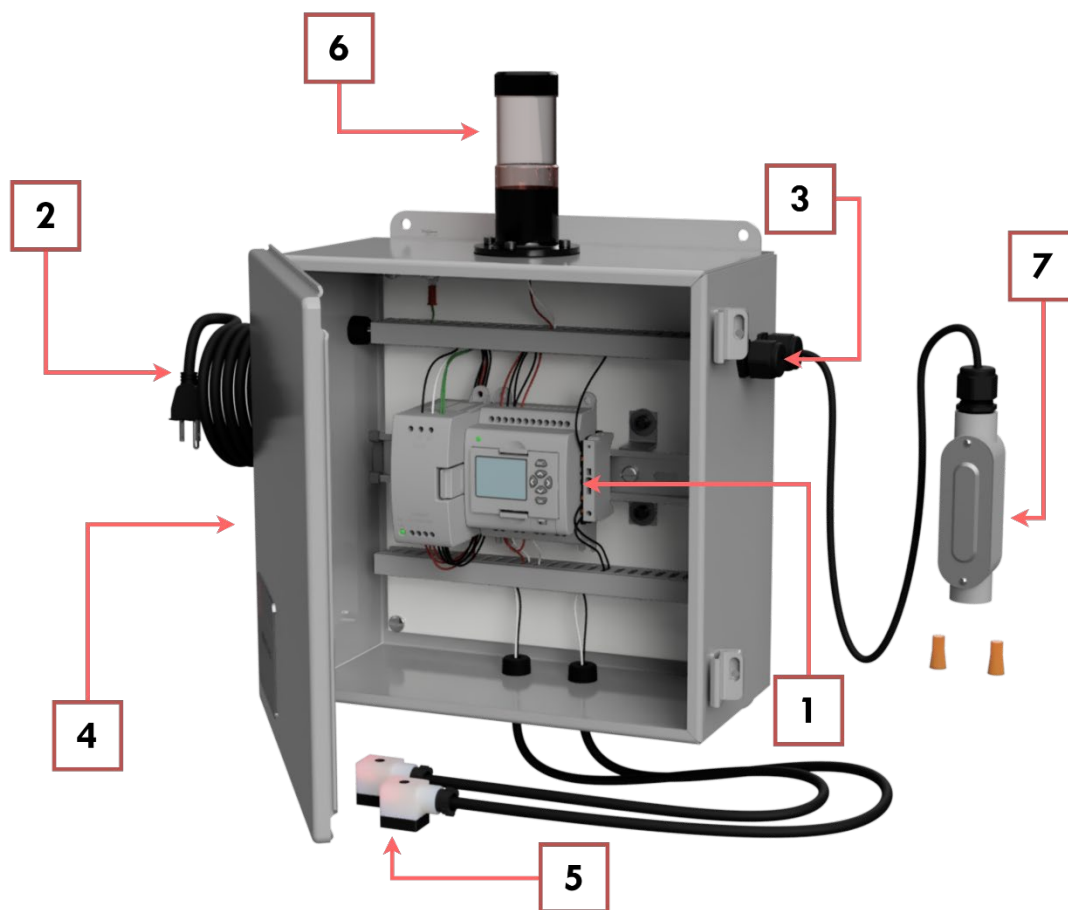

3 Assembly and Installation

PRIOR TO GETTING STARTED

- **WARNING!** *These systems operate using 110VAC and 24VDC. Do not touch any bare or exposed wires or terminals without confirming the system is not powered.*
- **WARNING!** *Wear safety glasses at all times.*
- **WARNING!** *Unplug the system during any assembly, disassembly, and related repairs.*
- **WARNING!** *To protect the electronics from dust and other particles in the air, tighten all cable glands, and do not leave the enclosure door open during normal operation.*
- **WARNING!** *AMCOL 6000-ETC systems are only designed to function with 6000E applicators and correctly retrofitted 6000P applicators with dual solenoid controls. For installation instructions for 6000E applicators, see the 6000E Operator's Manual.*

Installation

1. Review the system to see that no obvious damage has occurred in shipment.
2. See that all components are included and appropriate for your piece of equipment.
3. Ensure the system is located near a 110VAC outlet for power.
4. Mount the system controls in a well-protected area, which can be easily accessed by operations and maintenance personnel.
5. Attach prewired solenoid caps to existing dual solenoid connections.
6. Connect control signal wire from PLC or machine to ETC at input 0 through open cable gland. See wiring diagram for details.
7. Connect low-level switch from 6000E reservoir to ETC at input 1. See wiring diagram for details.
8. Ensure the 6000E system is installed correctly, and is ready to operate. Standard wire length from ETC to 6000E is 2'.
9. Operate the ETC manually, observing that the ETC and 6000E system function correctly together.
10. Adjust injection rate timing as necessary.
11. Under careful observation, operate system in production environment.

4 Recommended Settings

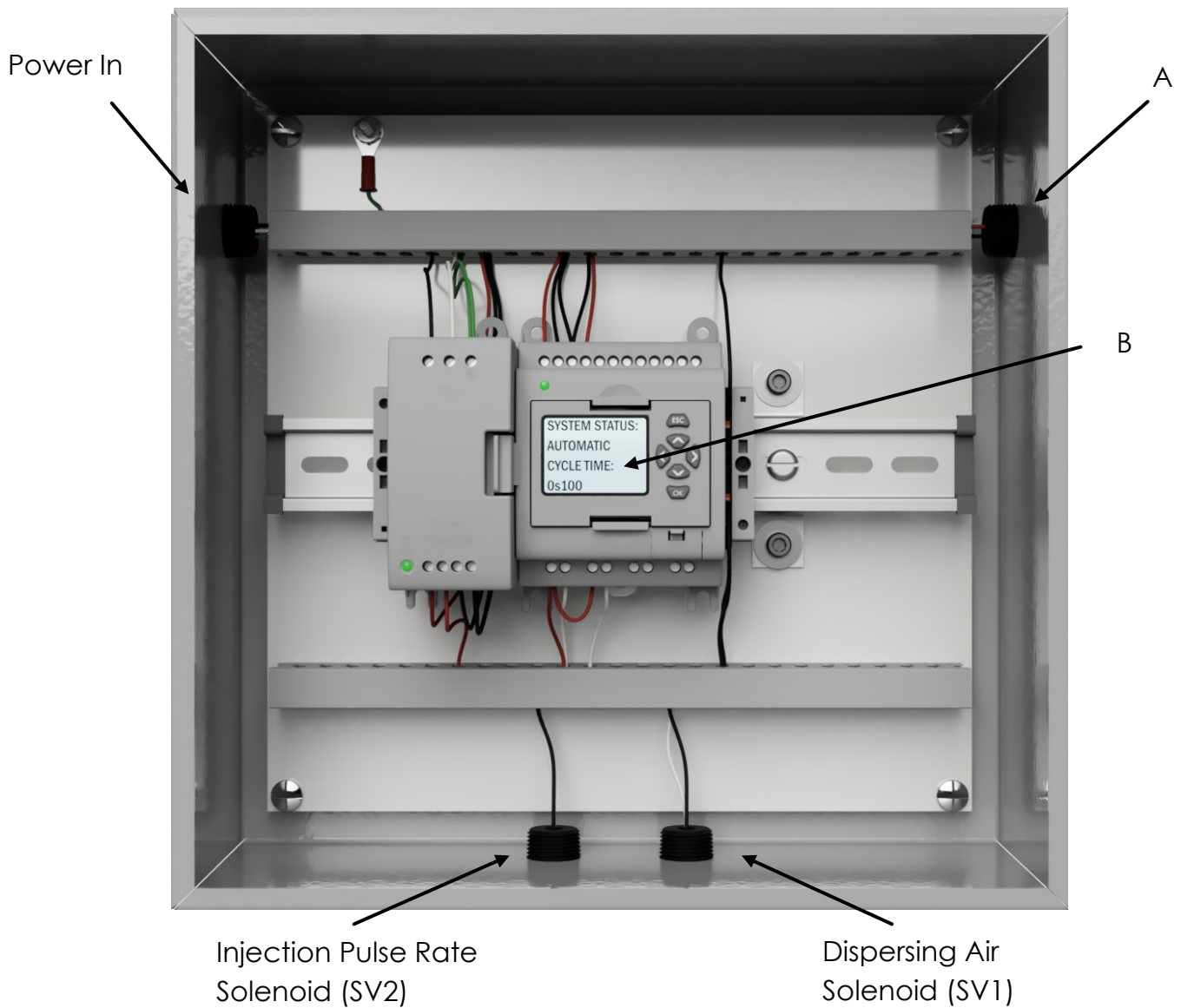

Item ID	Description	Recommended Setting
A	Control Input	Active when 6000E should be active
B	Injection Rate	According to machine cycle rate and volume

5 Operation

Prior to Getting Started

- Follow all operation guidelines outlined in the 6000E Operator's Manual for the 6000E system.
- Provide power to the ETC, either from a 110VAC outlet or 110VAC lead.
- If the low-level light is flashing, refill the reservoir on the 6000E applicator.

Setting Injection Pulse Rate

- Observe the current injection pulse rate setting on the LCD screen located inside the ETC enclosure.
- Press the up button on the PLC to increase the time between injections.
- Press the down button on the PLC to decrease the time between injections.
- Minimum cycle time for a T60A injector is 100ms (10 times per second).

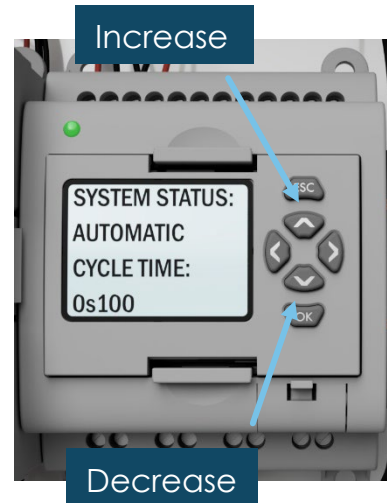

Proper Operation

Manual Actuation

To manually test the system to observe spray output, perform the following:

- Set the Injection Pulse Rate to the desired setting.
- Press and hold the left button on the PLC inside the ETC enclosure. The system status will display manual.

Manual operation should be used to verify current settings, test spray coating, and troubleshoot errors.

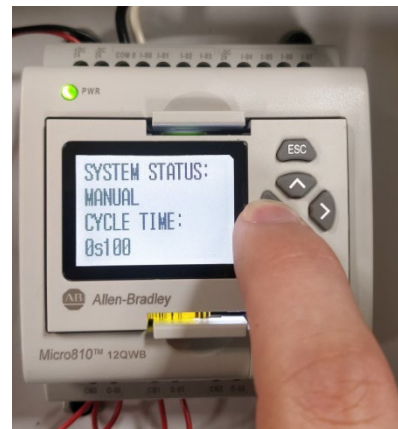

Automatic Actuation

To automatically use the 6000E system, it should be interfaced with a PLC or machine output, which should be wired into the ETC. When the PLC or machine output is on, the ETC will activate both solenoids on the 6000E automatically. The Dispersing Air Solenoid (SV1) will remain on as long as the output is on, and the Injection Pulse Rate Solenoid (SV2) will pulse at the set rate displayed on the ETC.

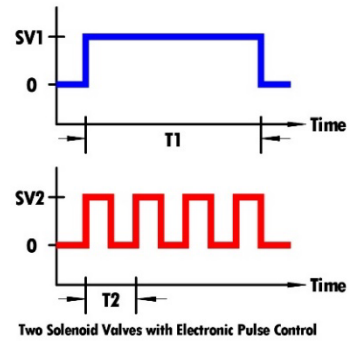

While running automatically, the spray volume and pattern should be consistent. No misting or fogging should be present. See the 6000E Operator's Manual for troubleshooting spray output issues.

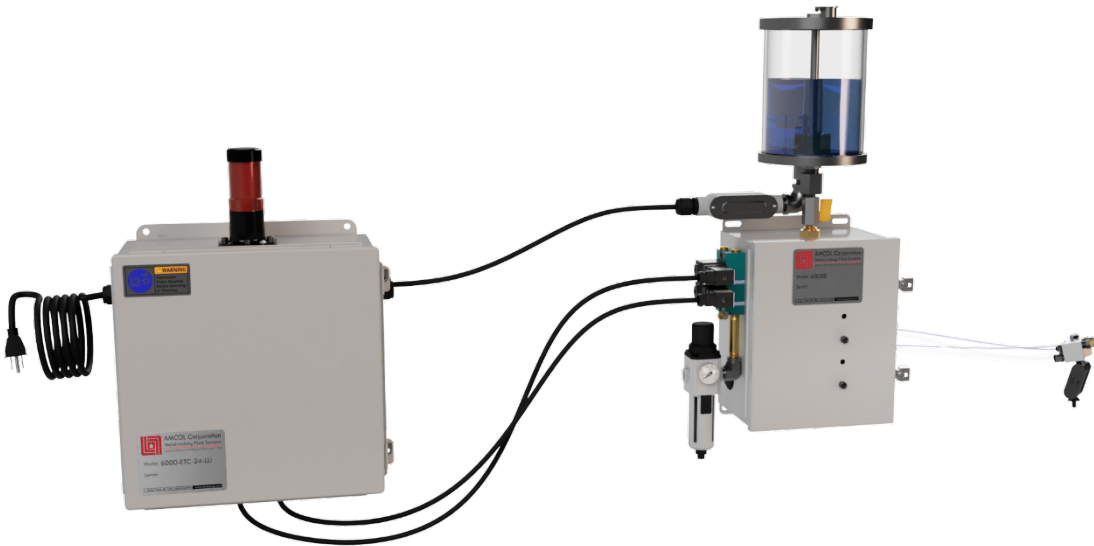

6 System Troubleshooting and Maintenance

For troubleshooting issues related to 6000E, see the 6000E Operator's Manual

Check in order as listed

System is not powering on

- Check if system is plugged in.
- Check if power cord wires are loose or unsecured in the terminals.
- Check if power outlet or lead is functioning correctly.

System is not activating solenoids

- Check connections from PLC and to the terminals. See wiring diagrams for correct connections if necessary.
- Check connections to solenoid caps.
- If the lights inside the caps are functioning, check the connection between the cap and solenoid on the 6000E.

Low level indicator is not functioning



- Check connections to the light and inputs on the ETC.
- Check wiring at the low-level switch on the reservoir.

LCD screen not displaying correct window

This error can occur from pressing the OK and ESC buttons at the same time

- Press any button on the PLC inside the ETC.
- Turn the ETC off and on.

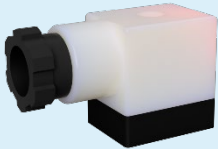
Recommended Spares

	Description	Part Number	Quantity
	Lighted cap for solenoid 24VDC 110VAC	E-01013-61	2
		E-01013-11	
	Cable gland	69915K54	1

7 Schematics

6000-ETC-110

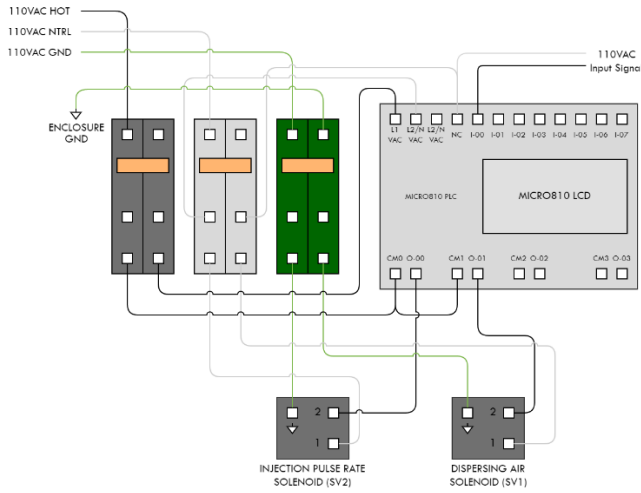

6000-ETC-24

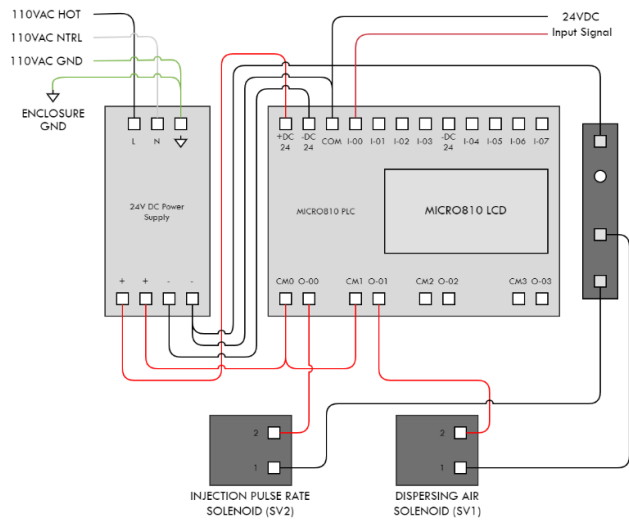

6000-ETC-110-LLI

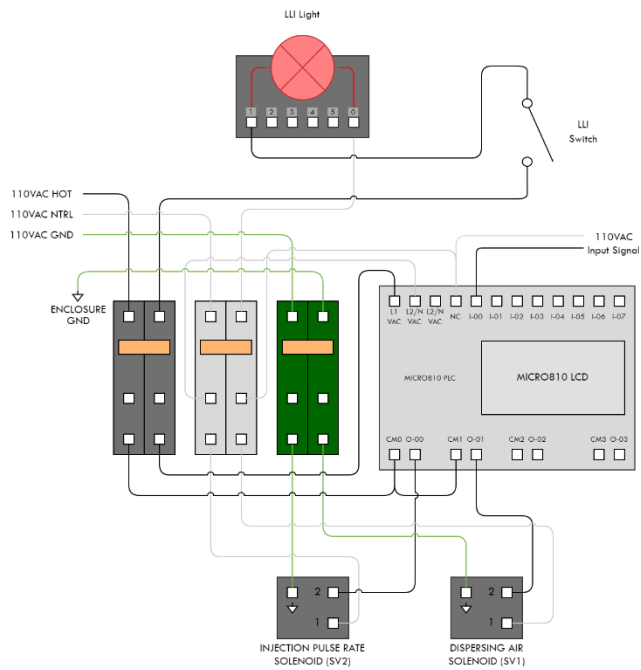

6000-ETC-24-LLI

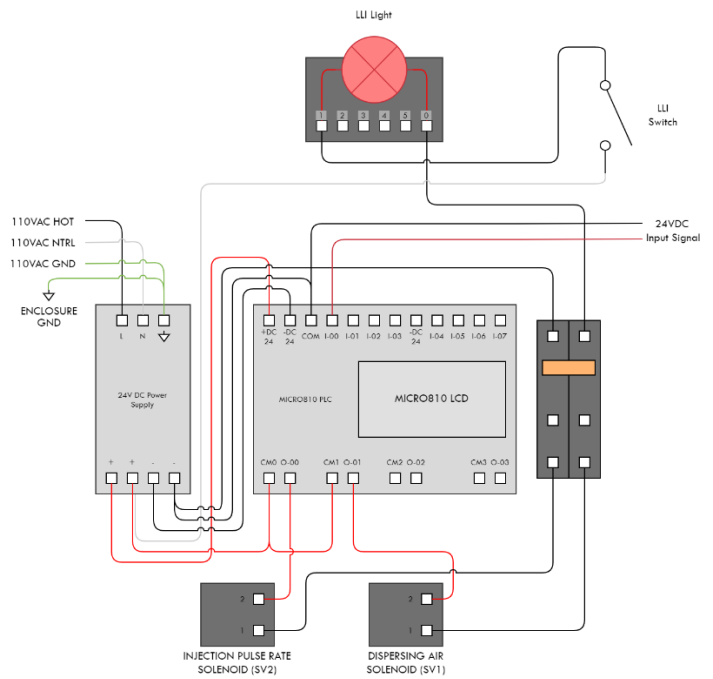



AMCOL Corporation

21435 Dequindre, Hazel Park, MI 48030	248-414-5700	fax: 248-414-7489	www.amcolcorp.com
---------------------------------------	--------------	-------------------	--